

Enabling Transnational Collection, Notification, and Sharing of Information

V. Cavalli-Sforza (violetta@cs.cmu.edu), A. I. Antón (anton@csc.ncsu.edu), O. Brooks (ndacc@btl.net),
J. Carbonell (jgc@cs.cmu.edu), R. Cole (cole@colorado.edu), R. Connolly (RConnolly@oas.org),
J. Fortes (fortes@ufl.edu), M. Herrera (consejo@codetel.net.do), I. Krsul (ivan@acis.ufl.edu),
C. McSweeney (cmcsween@ub.edu.bz), C. Ortega (COrtega@oas.org), S. Su (su@cise.ufl.edu),
D. Towsley (towsley@cs.umass.edu), J. Ventura (jventura@pucmmsti.edu.do), W. Ward (whw@colorado.edu)

University of Florida, Advanced Computing and Information Systems Laboratory
P.O. Box 116200, 339 Larsen Hall, Gainesville, FL, 32611-6200
<http://www.acis.ufl.edu/transdg>

Abstract: We describe efforts towards, and results of, a transnational collaboration between universities, government agencies, and an international organization in applying information technology (IT) to a problem of international concern: detecting and monitoring activities related to the transnational movement of illicit drugs. Starting from a general vision of how IT could assist in achieving this objective, we have agreed on likely user scenarios, infrastructure requirements and specifications for a prototype system whose initial focus is on collecting and sharing information related to the migration of individuals across borders. Albeit on a reduced scale, this system concretely exemplifies how information about potentially drug-related activities can be collected and accessed in different languages by privileged users through natural dialogue communication, and how it can be shared in a timely fashion to promote regional and international cooperation on solving the drug problem.

1. Introduction

Governments increasingly need to collaborate and share information with each other to solve global problems (Cole, Fortes, & Klinger, 1997). Information systems that support international collaborations among governments face challenges that require research on how to:

- Protect, control access to, filter, summarize, correlate and share information across agencies and organizations without compromising the security, laws, autonomy and culture of the countries;
- Interoperate transparently across countries whose heterogeneous information networks differ in design, reliability, performance and technological age; and
- Gather, represent, share, translate and retrieve multilingual information.

Significant expense and extensive overhead are currently incurred by different countries' agencies in the collection of data that vary in accuracy, completeness, promptness and compliance with international agreements. Information technology (IT) can play a major role in improving data quality, integrity, security, consistency and availability by facilitating the infrastructure, tools, protocols and communications needed to seamlessly integrate transnational activities into national government procedures. Our long-term vision is one where governments and public-service agencies can access and use each other's information infrastructure as if they were a part of a single information grid where information and services are securely deployed, shared in a controlled manner, and available with the necessary quality of service (QoS).

While working towards this ambitious goal, our project more modestly targets a process of transnational cooperation among universities, government agencies and an international organization in dealing with the negative impacts, on society, of illicit drug production, traffic and consumption. The process is coordinated by the Inter-American Drug Abuse Control Commission (CICAD) of the Organization of American States (OAS). The work is performed by a team of researchers from seven universities (U. of Belize, Pontificia Universidad Católica Madre y Maestra in the Dominican Republic, Carnegie Mellon U., North Carolina State U., U. of Colorado, U. of Florida, U. of Massachusetts) and experts from agencies in the three participating countries: CICAD's Inter-American Observatory on

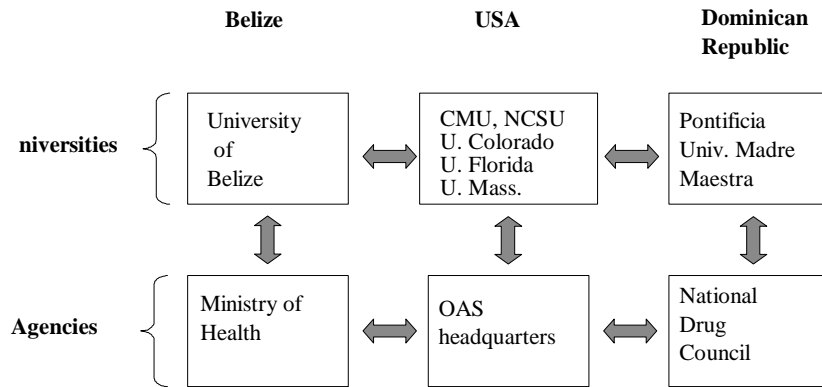

Figure 1: Project participants. Universities interact closely with each other and with agencies in their own countries; local universities and the OAS play a key role in the deployment of

Drugs, the National Drug Abuse Control Council (NDACC) of Belize's Ministry of Health, and the National Drug Council of the Dominican Republic (Figure 1).

Our research focuses on the deployment of technology and tools for collecting, processing, exchanging and integrating information needed for transnational collaboration, including:

- Spoken dialogue systems for data collection, information access and retrieval;
- Machine translation technology for gathering and sharing data in different languages;
- Active data management and security techniques for rule-based secure data sharing and filtering;
- Network behavior modeling and optimization for delivery of acceptable quality of service; and
- Middleware for transnational (heterogeneous) information grids that enable private, secure and dependable automation of collaboration processes and policies, and the delivery of computing services through Internet portals.

2. Context and Evolution of the Project

Our project builds on a focused multinational effort, the Multilateral Evaluation Mechanism (MEM). This effort, which is managed by OAS CICAD and includes participation by 34 OAS member states, has clearly defined objectives and provides a remarkable test bed for both tractable and extensible research in multinational digital government processes. The MEM involves the collection and analysis of data by, and from, several government agencies and non-government organizations within each country. The data in question, compiled through responses to a standard set of indicators negotiated among OAS member states, allows the generation of a report that measures national anti-drug efforts and inter-state cooperation for their improved execution. The use of the same indicators by participating nations fosters sharing information among agencies transnationally. Within a country, the MEM process also requires inter-agency collaboration, the need and importance of which is explicitly recognized via two indicators that refer to the existence of a mechanism for effecting coordination, cooperation and timely exchanges of information among national authorities with responsibilities for pharmaceuticals and controlled chemical substances. The implementation of the MEM process must currently contend with disjoint information systems in member nations, requiring additional efforts to collect and convey MEM data from and to those countries. Our project is a step towards automating the MEM process. The results are expected to scale and generalize to countries in the Americas beyond those currently involved in the project.

The initial vision for the project was formulated in an NSF-funded workshop for exploratory research on transnational digital government (May 9-11, 2001, Belize City, Belize): the goal was to identify ways in which IT could be used to help government agencies within Belize share information with each other, and, in some cases, with other countries. The participants included representatives of over 20 government departments and non-government organizations in Belize, government representatives from the Mexican State of Colima and the Dominican Republic (DR), representatives from the OAS, and U.S. and Belizean

researchers. One recommendation of the workshop was the construction of a Web portal with the tools, formats, and methodology useful for the collection, integration, indexing and sharing of national agency data. Although on a limited scale, our project is an example of the activities and cooperation among national and international organizations that are required to create such a portal.

Upon obtaining funding from the U.S. National Science Foundation, representatives of academic and governmental institutions in Belize, the DR, and the U.S. met in Santo Domingo twice during the fall of 2002. U.S. researchers presented different technologies and their envisioned application in the context of the overall goals of the project. Participants from Belize and the DR provided information about existing infrastructure and channels for collecting data relevant to illegal drugs. We agreed to focus on a specific MEM indicator, indicator #83 – ‘Displacement,’ whose objective is to identify “new trends in the global phenomenon of the mobility of the drug problem’s diverse manifestations”. The information used to respond to this indicator includes data on movement of individuals across borders, data independently collected for security purposes in both Belize and the DR at ports of entry (airports, maritime ports, and posts along the borders with Mexico, Guatemala and Haiti). We also agreed to aim the application of IT at supporting processes of collection, notification, and sharing of Data on Remote Border enforcement activities across the Dominican Republic and Belize. We refer to these processes by the acronym DRB.

3. The First System

The goal of the initial system is to demonstrate how IT can enhance DRB processes and become a useful tool for government agencies in each country in identifying and sharing among themselves and with other countries information about suspicious individuals attempting to cross national borders. The system will allow immigration agents at point-of-entry stations to:

- Enter information about specific individuals by scanning documents presented by travelers, typing the information contained in the documents or provided verbally in answer to the agent’s questions into a form, or using a voice/dialogue-based system where form-based entry is not possible;
- Query the system to verify information or supplement information provided by the traveler;
- Determine if the traveler is on a “watch list” of suspicious or wanted individuals;
- Import data on suspicious people from various agencies in each country into the local database;
- Receive information about appropriate actions to take for specific individuals;
- Specify system actions for specific individuals (e.g. notify specific law enforcement or intelligence agencies immediately for individuals on a “watch list”);
- Register to be notified of specific events by e-mails and/or cell phones (e.g. border crossings by specific individuals); and
- Access/transmit shareable data from/to the distributed databases of collaborating countries.

In support of this functionality, the system will overcome language barriers to communication by automatically translating free-text data typed by the agent or entered orally, and will allow secure access to data and data sharing by authorized individuals and agencies. In addition to the above functionality, the system will also provide a rich source of shared data for analyzing trends and identifying behavior patterns related to illegal activities. The envisioned system architecture is shown in Figure 2.

We are pursuing two paths simultaneously. We are developing an initial system that can be tested among the seven university sites. The system will support all of the major features listed above, thus enabling users at the university sites (and perhaps immigration project staff in Belize and the DR and at OAS) to interact with the system as system administrators, faux immigration agents, police or intelligence agency representatives and policy analysts. This aspect of research and development aims to provide a stable system with the desired features, and to enable stakeholders to participate in designing and refining the system. Simultaneously, project members are conducting research designed to understand and provide solutions to the practical realities of a system that can be deployed, maintained and used by

immigration agents and government agencies. This work includes visits to immigration stations and interviews with immigration agents in border regions to analyze existing infrastructure, social factors, traveler profiles, and other relevant information required to design a system that is robust, stable, secure, usable and useful. The DRB user interface will be developed following observation and analysis of agent-traveler interactions, and refined through an iterative design-and-test process that involves collaboration with immigration agents who will use the system from the earliest stages of the design process. Results from field and laboratory research will be continuously integrated to create an initial system that can be tested at selected immigration stations.

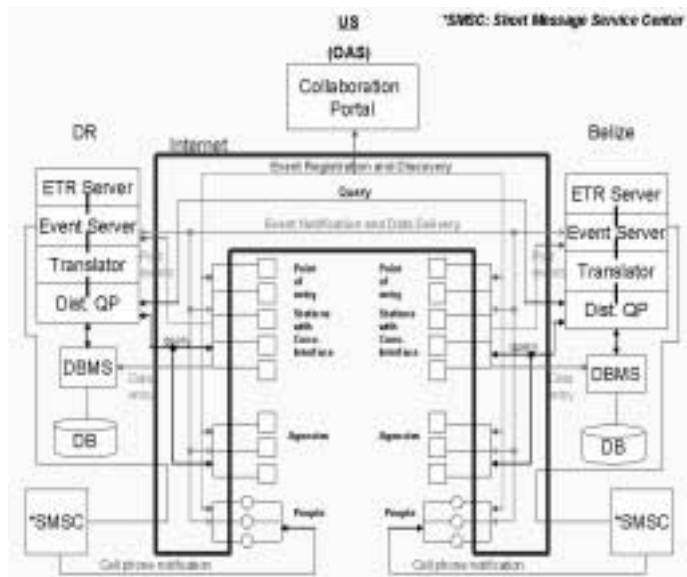

Figure 2: First version of DRB system

4. Conclusions

Our multi-university, multinational project aims to research and develop state-of-the-art IT to address global problems. Many of the barriers to a successful project are unknown at this point in time. Thus, our strategy is to first develop a working transnational system in a benign environment (universities, agency sites and OAS) while simultaneously trying to understand physical, political, social, cultural, financial, technical and other barriers to deploying and maintaining an effective system. We will improve the DRB process implementation prototype to overcome those obstacles that can be eliminated or alleviated by using information technology, and work with all stakeholders (including actual users of the final system) to further understand and address problems encountered in the field. An important consequence of our approach is that the use of leading-edge information technologies is dictated by the needs of the users and the practical realities of the DRB process implementation and use.

This project, like the controversial U.S. Computer Assisted Passenger Prescreening System (CAPPS) and its international version APIS, raises issues in relation to the security/privacy of information. The focus of our project, however, is to use IT to enable collection, notification and transnational sharing of information that is already used nationally within Belize and the DR. Therefore our main concern with respect to security/privacy issues will be to provide access to information in a way that complies with the different procedures and regulations of these two countries, and that will be extendable to other countries that may participate in the future. To address this we are: (1) using filters to keep information secure and private and (2) techniques for analysis of software requirements that align privacy and security. A possible further challenge for the future will be adherence to international agreements on related topics.

Acknowledgements: Research reported in this paper is funded in part by NSF awards EIA-0107686 and EIA-0131886. Any opinions, findings, and conclusions or recommendations expressed in this material are those of the author(s) and do not necessarily reflect the views of the National Science Foundation.

References

Cole, R.A., Fortes, J. A. B. and Klinger, A., "Workshop on International Collaboration in Computer Science and Engineering," Stevenson, Washington, October 9-11, 1997, <http://cslu.cse.ogi.edu/nsf/wiccs97/report.html>