

Exceptional Control Flow: Exceptions and Processes

15-213 / 18-213: Introduction to Computer Systems
13th Lecture, Feb. 28, 2011

Instructors:

Todd C. Mowry & Anthony Rowe

Today

- **Exceptional Control Flow**
- Processes

Control Flow

■ Processors do only one thing:

- From startup to shutdown, a CPU simply reads and executes (interprets) a sequence of instructions, one at a time
- This sequence is the CPU's *control flow* (or *flow of control*)

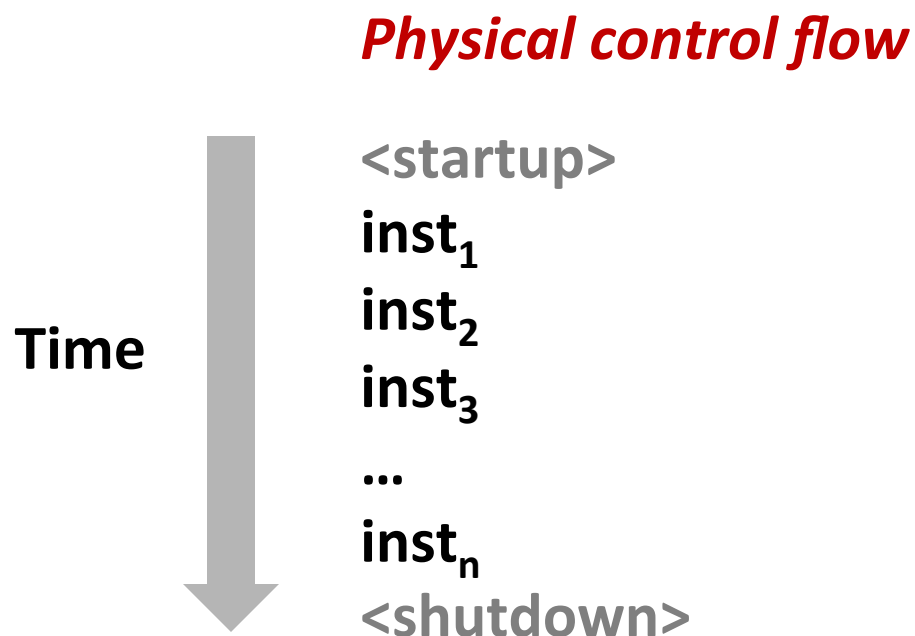

Altering the Control Flow

- **Up to now: two mechanisms for changing control flow:**

- Jumps and branches
- Call and return

Both react to changes in *program state*

- **Insufficient for a useful system:**

Difficult to react to changes in *system state*

- data arrives from a disk or a network adapter
- instruction divides by zero
- user hits Ctrl-C at the keyboard
- System timer expires

- **System needs mechanisms for “exceptional control flow”**

Exceptional Control Flow

- **Exists at all levels of a computer system**
- **Low level mechanisms**
 - Exceptions
 - change in control flow in response to a system event (i.e., change in system state)
 - Combination of hardware and OS software
- **Higher level mechanisms**
 - Process context switch
 - Signals
 - Nonlocal jumps: `setjmp()/longjmp()`
 - Implemented by either:
 - OS software (context switch and signals)
 - C language runtime library (nonlocal jumps)

Exceptions

- An **exception** is a transfer of control to the OS in response to some **event** (i.e., change in processor state)

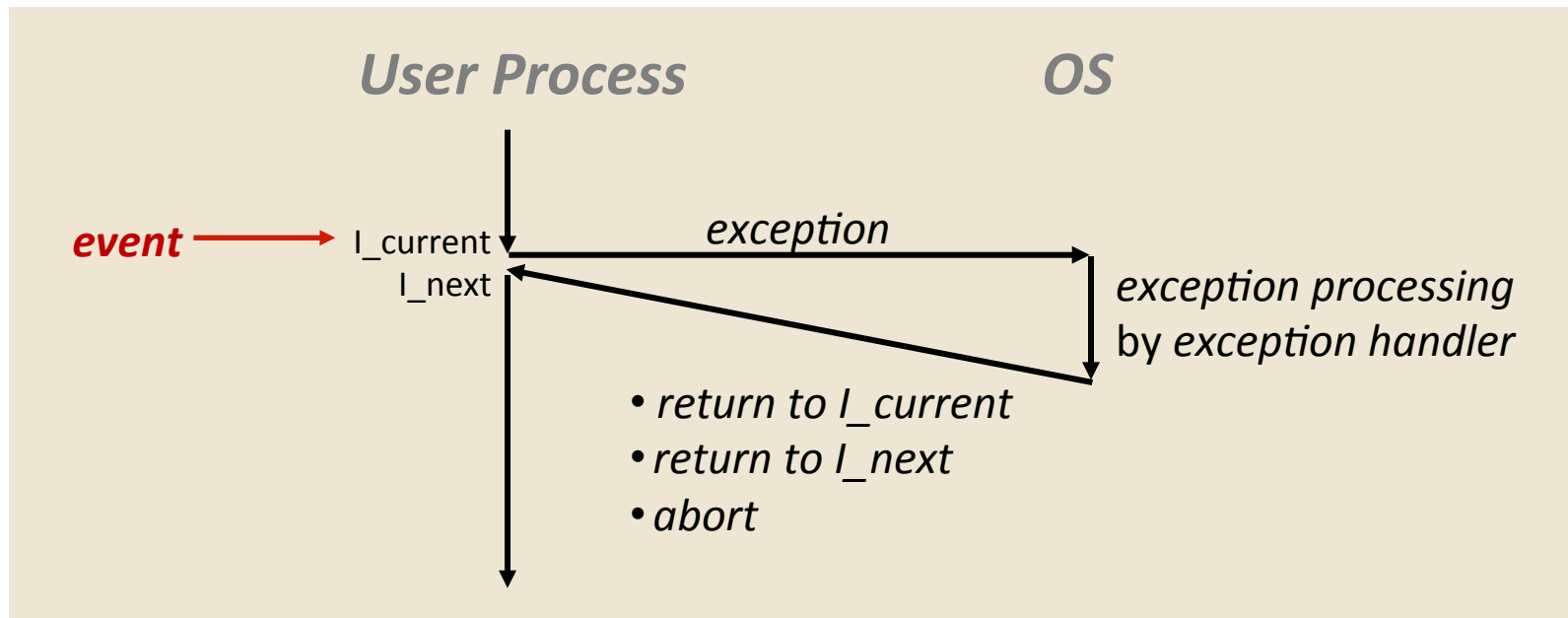

- **Examples:**
div by 0, arithmetic overflow, page fault, I/O request completes, Ctrl-C

Exception Tables

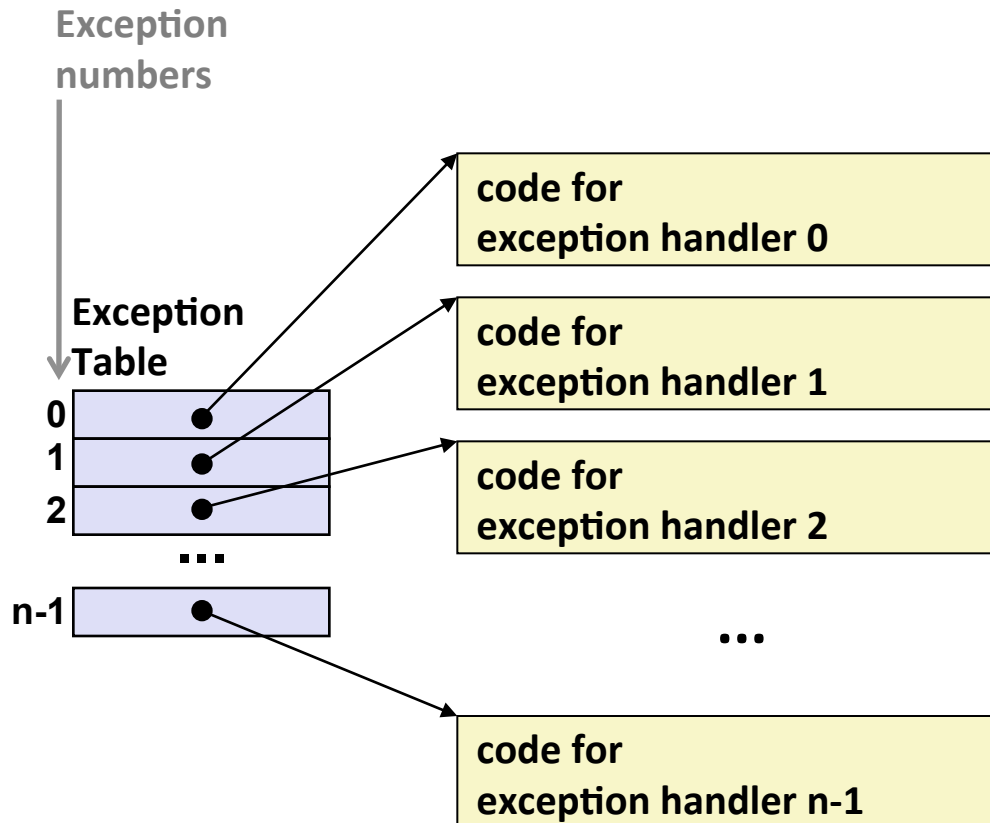

- Each type of event has a unique exception number k
- k = index into exception table (a.k.a. interrupt vector)
- Handler k is called each time exception k occurs

Asynchronous Exceptions (Interrupts)

- **Caused by events external to the processor**
 - Indicated by setting the processor's interrupt pin
 - Handler returns to "next" instruction

- **Examples:**
 - I/O interrupts
 - hitting Ctrl-C at the keyboard
 - arrival of a packet from a network
 - arrival of data from a disk
 - Hard reset interrupt
 - hitting the reset button
 - Soft reset interrupt
 - hitting Ctrl-Alt-Delete on a PC

Synchronous Exceptions

- **Caused by events that occur as a result of executing an instruction:**
 - ***Traps***
 - Intentional
 - Examples: ***system calls***, breakpoint traps, special instructions
 - Returns control to “next” instruction
 - ***Faults***
 - Unintentional but possibly recoverable
 - Examples: page faults (recoverable), protection faults (unrecoverable), floating point exceptions
 - Either re-executes faulting (“current”) instruction or aborts
 - ***Aborts***
 - unintentional and unrecoverable
 - Examples: parity error, machine check
 - Aborts current program

Trap Example: Opening File

- User calls: `open(filename, options)`
- Function `open` executes system call instruction `int`

```

0804d070 <__libc_open>:
. . .
804d082:      cd 80          int     $0x80
804d084:      5b            pop    %ebx
. . .

```

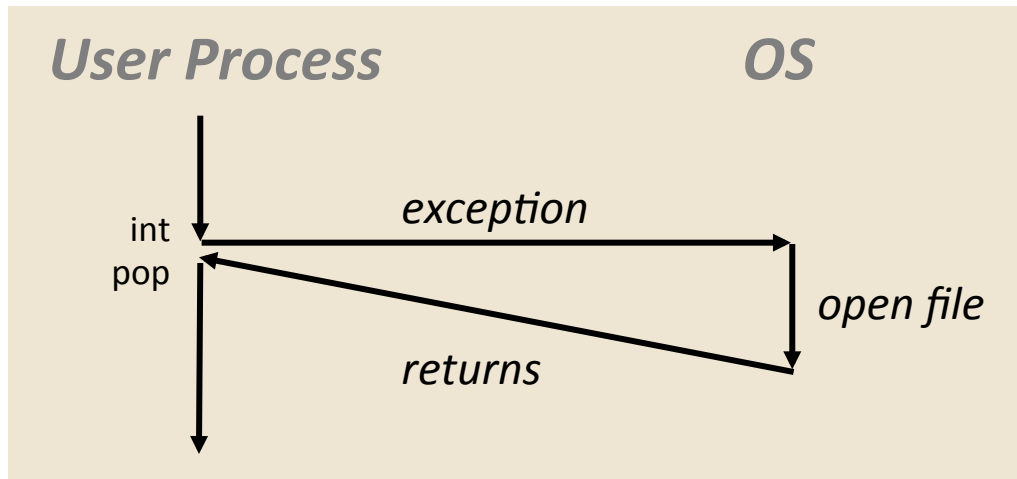

- OS must find or create file, get it ready for reading or writing
- Returns integer file descriptor

Fault Example: Page Fault

- User writes to memory location
- That portion (page) of user's memory is currently on disk

```
int a[1000];
main ()
{
    a[500] = 13;
}
```

```
80483b7:      c7 05 10 9d 04 08 0d  movl   $0xd,0x8049d10
```

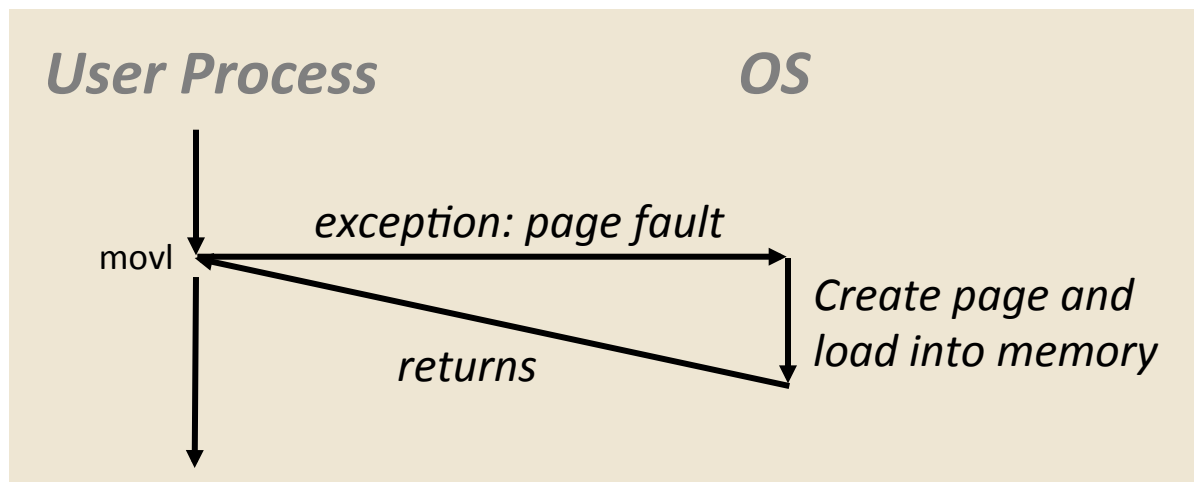

- Page handler must load page into physical memory
- Returns to faulting instruction
- Successful on second try

Fault Example: Invalid Memory Reference

```
int a[1000];  
main ()  
{  
    a[5000] = 13;  
}
```

```
80483b7:    c7 05 60 e3 04 08 0d    movl    $0xd,0x804e360
```

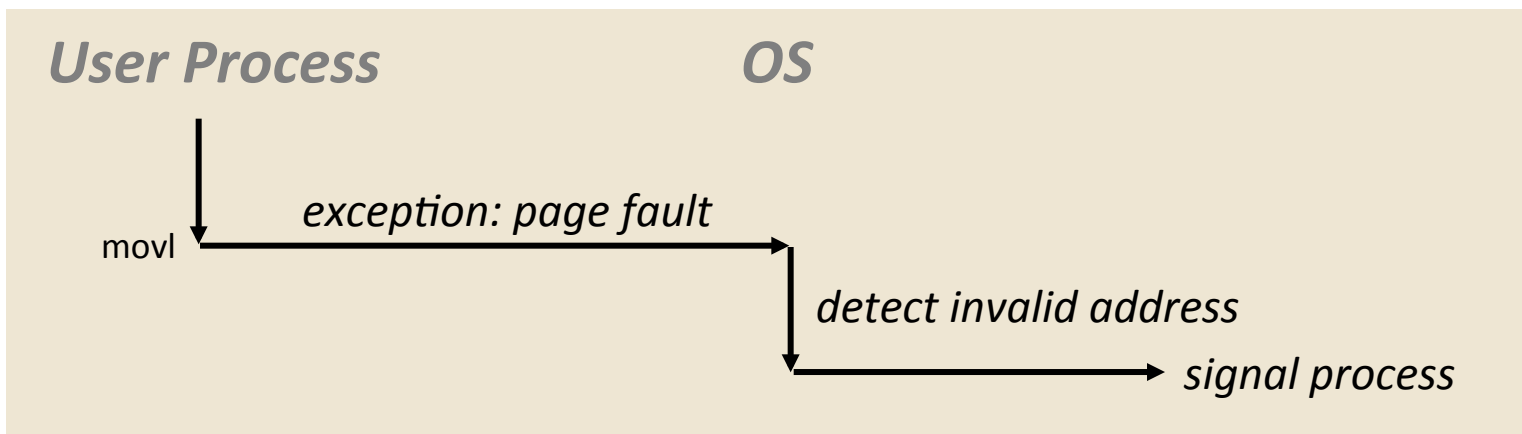

- Page handler detects invalid address
- Sends **SIGSEGV** signal to user process
- User process exits with “segmentation fault”

Exception Table IA32 (Excerpt)

<i>Exception Number</i>	<i>Description</i>	<i>Exception Class</i>
0	Divide error	Fault
13	General protection fault	Fault
14	Page fault	Fault
18	Machine check	Abort
32-127	OS-defined	Interrupt or trap
128 (0x80)	System call	Trap
129-255	OS-defined	Interrupt or trap

Check Table 6-1:

<http://download.intel.com/design/processor/manuals/253665.pdf>

Today

- Exceptional Control Flow
- **Processes**

Processes

- **Definition: A *process* is an instance of a running program.**
 - One of the most profound ideas in computer science
 - Not the same as “program” or “processor”
- **Process provides each program with two key abstractions:**
 - Logical control flow
 - Each program seems to have exclusive use of the CPU
 - Private virtual address space
 - Each program seems to have exclusive use of main memory
- **How are these Illusions maintained?**
 - Process executions interleaved (multitasking) or run on separate cores
 - Address spaces managed by virtual memory system
 - we’ll talk about this in a couple of weeks

Concurrent Processes

- Two processes *run concurrently* (are concurrent) if their flows overlap in time
- Otherwise, they are *sequential*
- Examples (running on single core):
 - Concurrent: A & B, A & C
 - Sequential: B & C

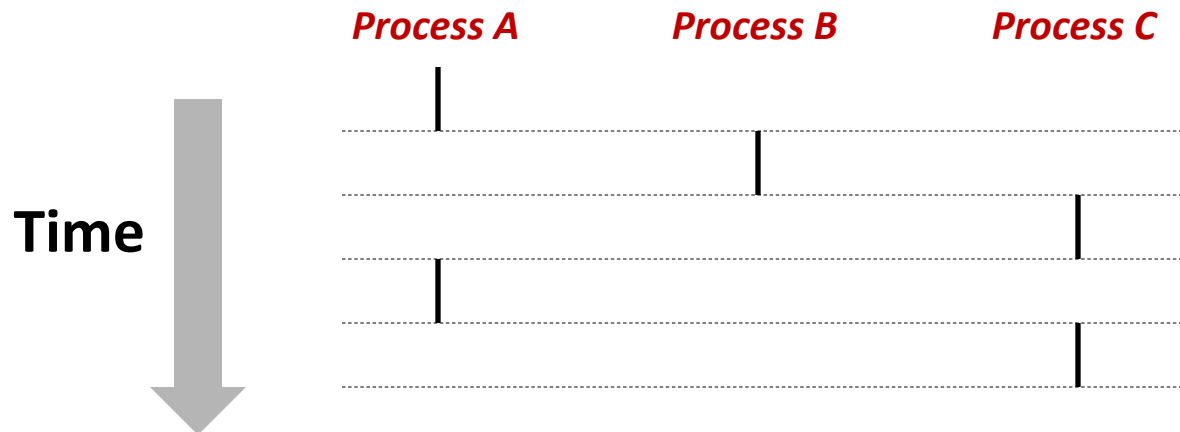

User View of Concurrent Processes

- Control flows for concurrent processes are physically disjoint in time
- However, we can think of concurrent processes as running in parallel with each other

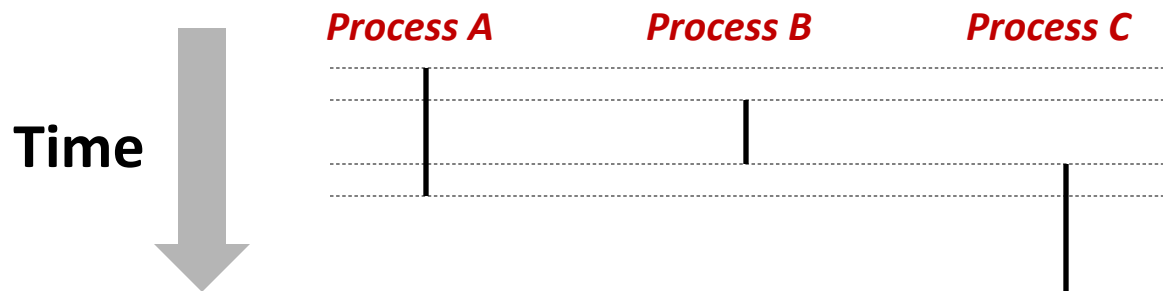

Context Switching

- Processes are managed by a shared chunk of OS code called the *kernel*
 - Important: the kernel is not a separate process, but rather runs as part of some user process
- Control flow passes from one process to another via a *context switch*

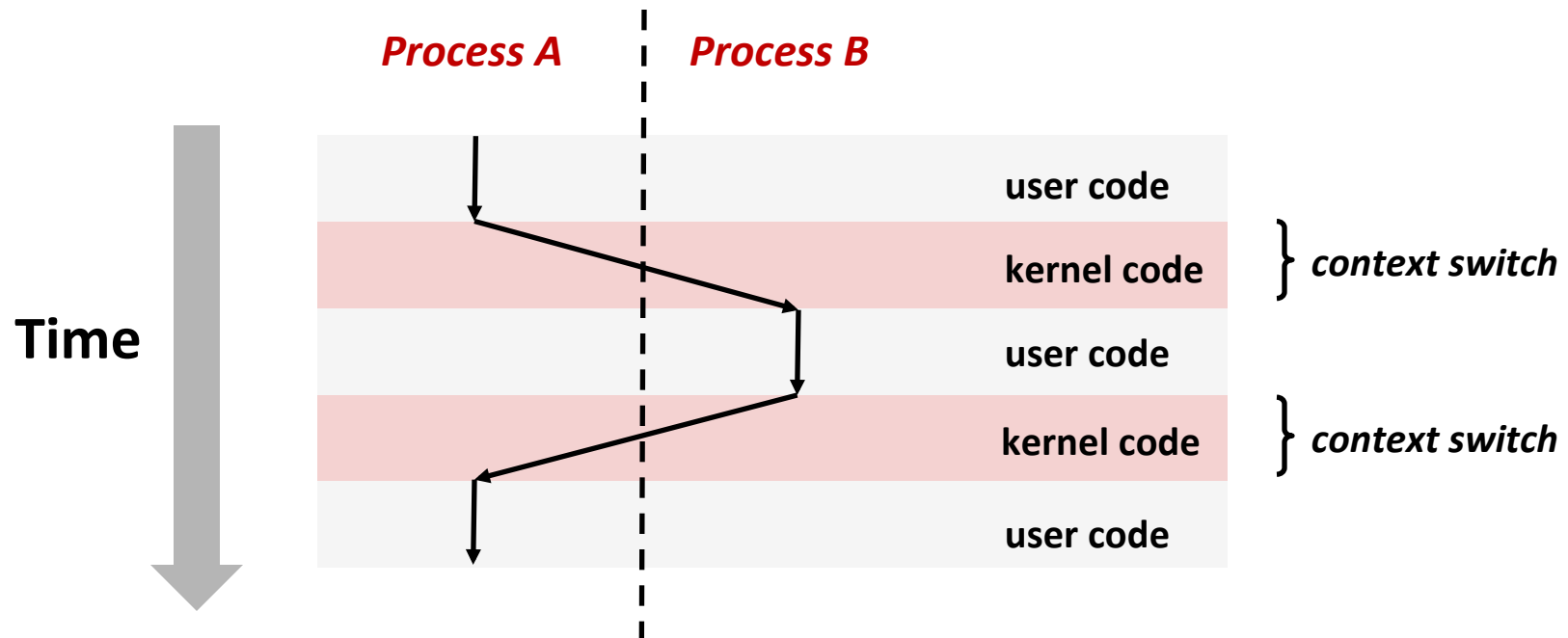

fork: Creating New Processes

■ `int fork(void)`

- creates a new process (child process) that is identical to the calling process (parent process)
- returns 0 to the child process
- returns child's `pid` (process id) to the parent process

```
pid_t pid = fork();
if (pid == 0) {
    printf("hello from child\n");
} else {
    printf("hello from parent\n");
}
```

- Fork is interesting (and often confusing) because it is called *once* but returns *twice*

Understanding fork

Process n



```
pid_t pid = fork();
if (pid == 0) {
    printf("hello from child\n");
} else {
    printf("hello from parent\n");
}
```

Child Process m



```
pid_t pid = fork();
if (pid == 0) {
    printf("hello from child\n");
} else {
    printf("hello from parent\n");
}
```



pid = m

```
pid_t pid = fork();
if (pid == 0) {
    printf("hello from child\n");
} else {
    printf("hello from parent\n");
}
```



pid = 0

```
pid_t pid = fork();
if (pid == 0) {
    printf("hello from child\n");
} else {
    printf("hello from parent\n");
}
```



```
pid_t pid = fork();
if (pid == 0) {
    printf("hello from child\n");
} else {
    printf("hello from parent\n");
}
```



```
pid_t pid = fork();
if (pid == 0) {
    printf("hello from child\n");
} else {
    printf("hello from parent\n");
}
```

hello from parent

Which one is first?

hello from child

Fork Example #1

- **Parent and child both run same code**
 - Distinguish parent from child by return value from `fork`
- **Start with same state, but each has private copy**
 - Including shared output file descriptor
 - Relative ordering of their print statements undefined

```
void fork1()
{
    int x = 1;
    pid_t pid = fork();
    if (pid == 0) {
        printf("Child has x = %d\n", ++x);
    } else {
        printf("Parent has x = %d\n", --x);
    }
    printf("Bye from process %d with x = %d\n", getpid(), x);
}
```

Fork Example #2

- Two consecutive forks

```
void fork2()  
{  
    printf("L0\n");  
    fork();  
    printf("L1\n");  
    fork();  
    printf("Bye\n");  
}
```

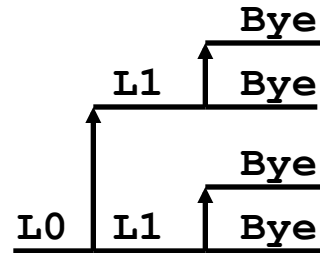

Fork Example #3

■ Three consecutive forks

```
void fork3()
{
    printf("L0\n");
    fork();
    printf("L1\n");
    fork();
    printf("L2\n");
    fork();
    printf("Bye\n");
}
```

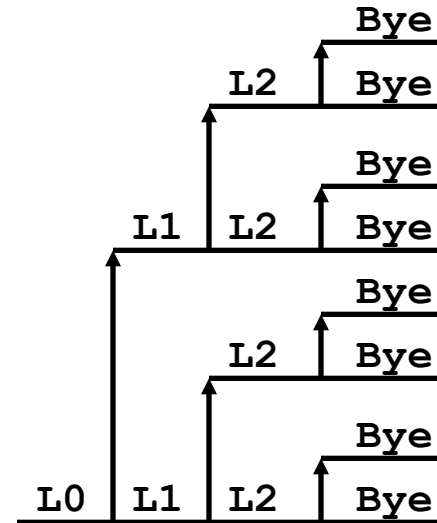

Fork Example #4

■ Nested forks in parent

```
void fork4()  
{  
    printf("L0\n");  
    if (fork() != 0) {  
        printf("L1\n");  
        if (fork() != 0) {  
            printf("L2\n");  
            fork();  
        }  
    }  
    printf("Bye\n");  
}
```

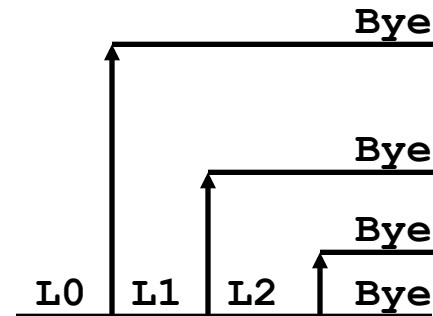

Fork Example #5

■ Nested forks in children

```
void fork5()
{
    printf("L0\n");
    if (fork() == 0) {
        printf("L1\n");
        if (fork() == 0) {
            printf("L2\n");
            fork();
        }
    }
    printf("Bye\n");
}
```

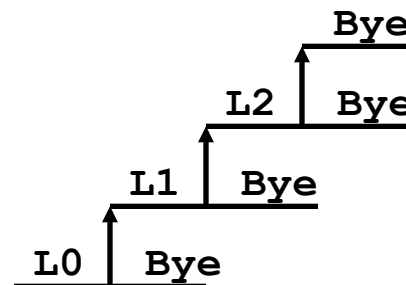

exit: Ending a process

- `void exit(int status)`
 - exits a process
 - Normally return with status 0
 - `atexit()` registers functions to be executed upon exit

```
void cleanup(void) {  
    printf("cleaning up\n");  
}  
  
void fork6() {  
    atexit(cleanup);  
    fork();  
    exit(0);  
}
```

Zombies

■ Idea

- When process terminates, still consumes system resources
 - Various tables maintained by OS
- Called a “zombie”
 - Living corpse, half alive and half dead

■ Reaping

- Performed by parent on terminated child (using `wait` or `waitpid`)
- Parent is given exit status information
- Kernel discards process

■ What if parent doesn't reap?

- If any parent terminates without reaping a child, then child will be reaped by `init` process (`pid == 1`)
- So, only need explicit reaping in long-running processes
 - e.g., shells and servers

Zombie Example

```
linux> ./forks 7 &
[1] 6639
Running Parent, PID = 6639
Terminating Child, PID = 6640
linux> ps
  PID TTY          TIME CMD
 6585 ttyp9        00:00:00 tcsh
 6639 ttyp9        00:00:03 forks
 6640 ttyp9        00:00:00 forks <defunct>
 6641 ttyp9        00:00:00 ps
linux> kill 6639
[1] Terminated
linux> ps
  PID TTY          TIME CMD
 6585 ttyp9        00:00:00 tcsh
 6642 ttyp9        00:00:00 ps
```

```
void fork7()
{
    if (fork() == 0) {
        /* Child */
        printf("Terminating Child, PID = %d\n",
            getpid());
        exit(0);
    } else {
        printf("Running Parent, PID = %d\n",
            getpid());
        while (1)
            ; /* Infinite loop */
    }
}
```

- `ps` shows child process as “defunct”
- Killing parent allows child to be reaped by `init`

Nonterminating Child Example

```
void fork8()
{
    if (fork() == 0) {
        /* Child */
        printf("Running Child, PID = %d\n",
            getpid());
        while (1)
            ; /* Infinite loop */
    } else {
        printf("Terminating Parent, PID = %d\n",
            getpid());
        exit(0);
    }
}
```

```
linux> ./forks 8
Terminating Parent, PID = 6675
Running Child, PID = 6676
linux> ps
  PID TTY          TIME CMD
 6585 ttyp9        00:00:00 tcsh
 6676 ttyp9        00:00:06 forks
 6677 ttyp9        00:00:00 ps
linux> kill 6676
linux> ps
  PID TTY          TIME CMD
 6585 ttyp9        00:00:00 tcsh
 6678 ttyp9        00:00:00 ps
```

- Child process still active even though parent has terminated
- Must kill explicitly, or else will keep running indefinitely

`wait`: Synchronizing with Children

- Parent reaps child by calling the `wait` function
- `int wait(int *child_status)`
 - suspends current process until one of its children terminates
 - return value is the `pid` of the child process that terminated
 - if `child_status != NULL`, then the object it points to will be set to a status indicating why the child process terminated

wait: Synchronizing with Children

```
void fork9() {
    int child_status;

    if (fork() == 0) {
        printf("HC: hello from child\n");
    }
    else {
        printf("HP: hello from parent\n");
        wait(&child_status);
        printf("CT: child has terminated\n");
    }
    printf("Bye\n");
    exit();
}
```

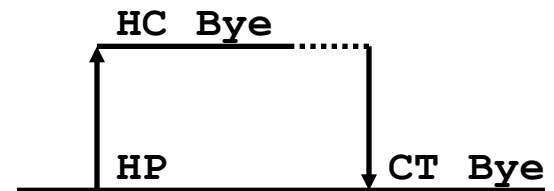

wait() Example

- If multiple children completed, will take in arbitrary order
- Can use macros WIFEXITED and WEXITSTATUS to get information about exit status

```
void fork10()
{
    pid_t pid[N];
    int i;
    int child_status;
    for (i = 0; i < N; i++)
        if ((pid[i] = fork()) == 0)
            exit(100+i); /* Child */
    for (i = 0; i < N; i++) {
        pid_t wpid = wait(&child_status);
        if (WIFEXITED(child_status))
            printf("Child %d terminated with exit status %d\n",
                wpid, WEXITSTATUS(child_status));
        else
            printf("Child %d terminate abnormally\n", wpid);
    }
}
```



waitpid() : Waiting for a Specific Process

- `waitpid(pid, &status, options)`
 - suspends current process until specific process terminates
 - various options (see textbook)

```
void fork11()
{
    pid_t pid[N];
    int i;
    int child_status;
    for (i = 0; i < N; i++)
        if ((pid[i] = fork()) == 0)
            exit(100+i); /* Child */
    for (i = N-1; i >= 0; i--) {
        pid_t wpid = waitpid(pid[i], &child_status, 0);
        if (WIFEXITED(child_status))
            printf("Child %d terminated with exit status %d\n",
                wpid, WEXITSTATUS(child_status));
        else
            printf("Child %d terminated abnormally\n", wpid);
    }
}
```

execve: Loading and Running Programs

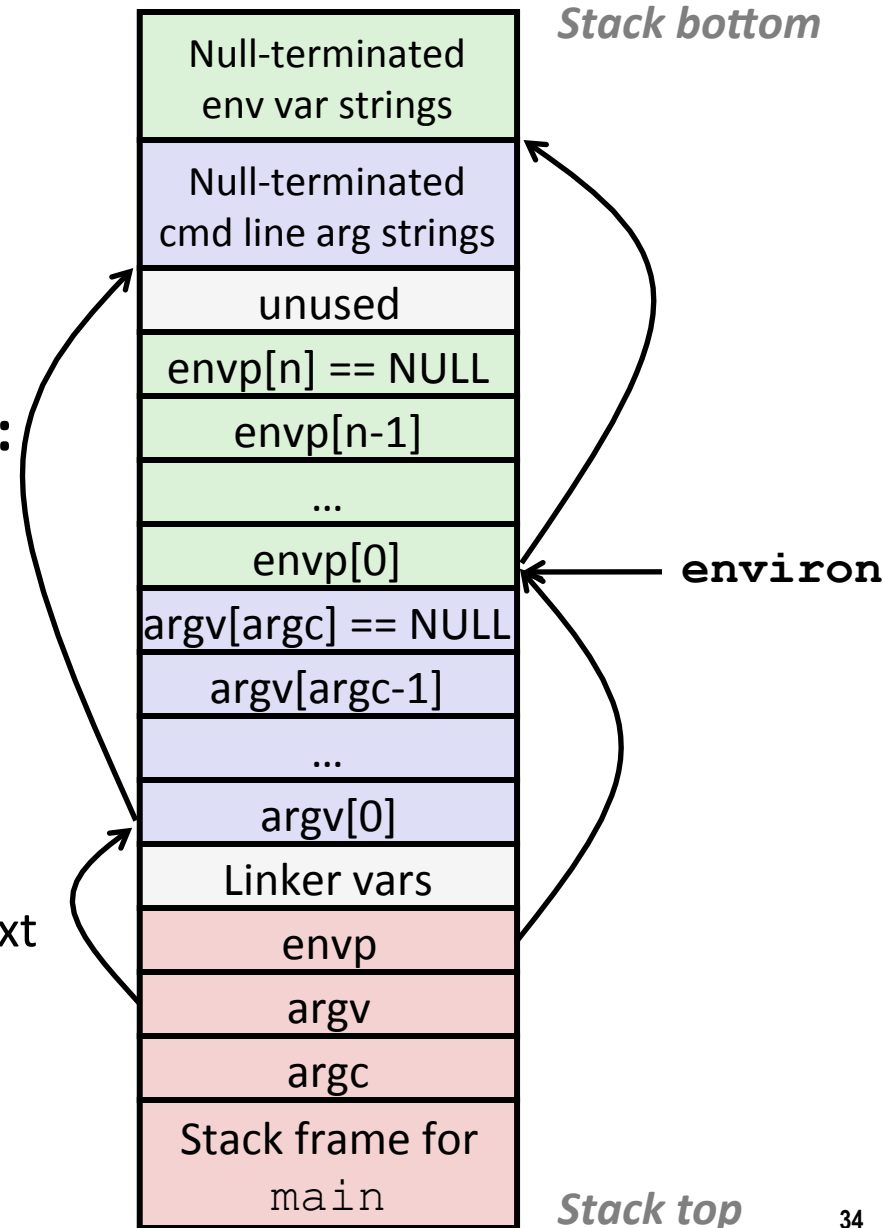
- `int execve(`
`char *filename,`
`char *argv[],`
`char *envp[]`
`)`
- **Loads and runs in current process:**
 - Executable `filename`
 - With argument list `argv`
 - And environment variable list `envp`
- **Does not return (unless error)**
- **Overwrites code, data, and stack**
 - keeps pid, open files and signal context
- **Environment variables:**
 - “name=value” strings
 - `getenv` and `putenv`



execve Example

```
if ((pid = Fork()) == 0) { /* Child runs user job */
    if (execve(argv[0], argv, environ) < 0) {
        printf("%s: Command not found.\n", argv[0]);
        exit(0);
    }
}
```

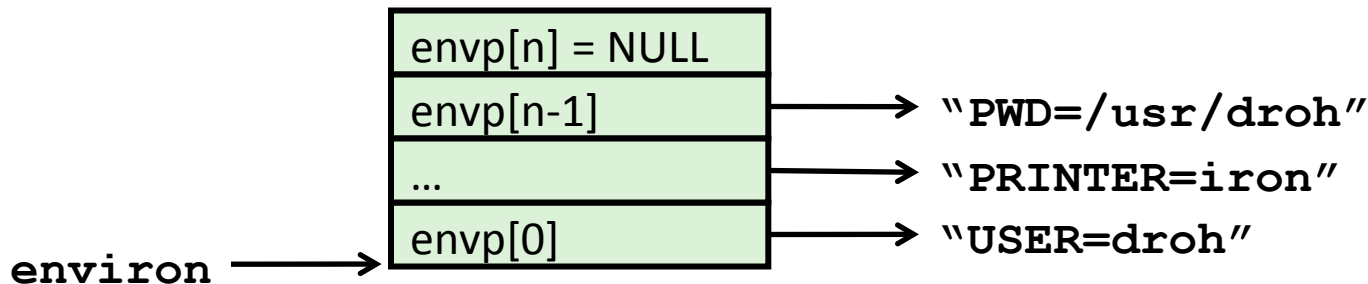
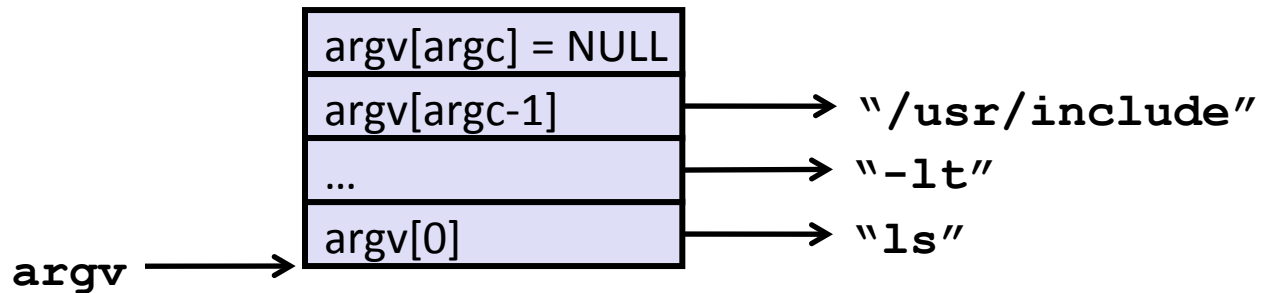

Summary

■ Exceptions

- Events that require nonstandard control flow
- Generated externally (interrupts) or internally (traps and faults)

■ Processes

- At any given time, system has multiple active processes
- Only one can execute at a time on a single core, though
- Each process appears to have total control of processor + private memory space

Summary (cont.)

■ Spawning processes

- Call `fork`
- One call, two returns

■ Process completion

- Call `exit`
- One call, no return

■ Reaping and waiting for processes

- Call `wait` or `waitpid`

■ Loading and running programs

- Call `execve` (or variant)
- One call, (normally) no return