

Machine-Level Programming II: Switch Statements and IA32 Procedures

15-213 / 18-213: Introduction to Computer Systems
7th Lecture, Feb. 7th, 2012

Instructors:

Todd C. Mowry & Anthony Rowe

Today

- **Switch statements**
- **IA 32 Procedures**
 - Stack Structure
 - Calling Conventions
 - Illustrations of Recursion & Pointers

```
long switch_eg
(long x, long y, long z)
{
    long w = 1;
    switch(x) {
    case 1:
        w = y*z;
        break;
    case 2:
        w = y/z;
        /* Fall Through */
    case 3:
        w += z;
        break;
    case 5:
    case 6:
        w -= z;
        break;
    default:
        w = 2;
    }
    return w;
}
```

Switch Statement Example

- **Multiple case labels**
 - Here: 5 & 6
- **Fall through cases**
 - Here: 2
- **Missing cases**
 - Here: 4

Jump Table Structure

Switch Form

```
switch(x) {
  case val_0:
    Block 0
  case val_1:
    Block 1
    . . .
  case val_n-1:
    Block n-1
}
```

Jump Table

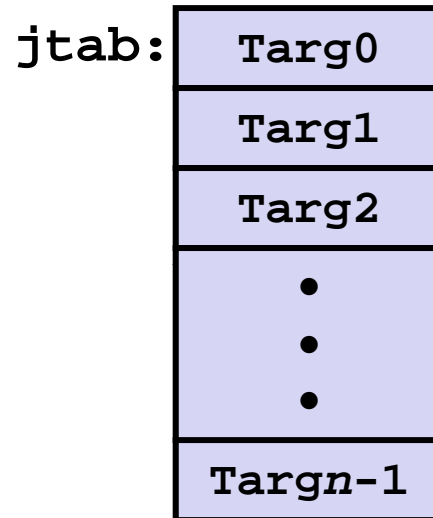

Jump Targets

Targ0:

Code Block
0

Targ1:

Code Block
1

Targ2:

Code Block
2•
•
•

Targn-1:

Code Block
n-1

Approximate Translation

```
target = JTab[x];
goto *target;
```

Switch Statement Example (IA32)

```

long switch_eg(long x, long y, long z)
{
    long w = 1;
    switch(x) {
        . . .
    }
    return w;
}

```

What range of values takes default?

Setup:

```

switch_eg:
    pushl   %ebp           # Setup
    movl   %esp, %ebp     # Setup
    movl   8(%ebp), %eax   # %eax = x
    cmpl   $6, %eax       # Compare x:6
    ja     .L2             # If unsigned > goto default
    jmp    *.L7(, %eax, 4) # Goto *JTab[x]

```

Note that **w** not initialized here

Switch Statement Example (IA32)

```

long switch_eg(long x, long y, long z)
{
    long w = 1;
    switch(x) {
        . . .
    }
    return w;
}

```

Jump table

```

.section      .rodata
    .align 4
.L7:
    .long     .L2 # x = 0
    .long     .L3 # x = 1
    .long     .L4 # x = 2
    .long     .L5 # x = 3
    .long     .L2 # x = 4
    .long     .L6 # x = 5
    .long     .L6 # x = 6

```

Setup:

```

switch_eg:
    pushl    %ebp                # Setup
    movl    %esp, %ebp          # Setup
    movl    8(%ebp), %eax        # eax = x
    cmpl    $6, %eax           # Compare x:6
    ja     .L2                  # If unsigned > goto default
    Indirect
    jump  jmp     *.L7(,%eax,4) # Goto *JTab[x]

```

Assembly Setup Explanation

■ Table Structure

- Each target requires 4 bytes
- Base address at `.L7`

■ Jumping

- **Direct:** `jmp .L2`
- Jump target is denoted by label `.L2`
- **Indirect:** `jmp *.L7(,%eax,4)`
- Start of jump table: `.L7`
- Must scale by factor of 4 (labels have 32-bits = 4 Bytes on IA32)
- Fetch target from effective Address `.L7 + eax*4`
 - Only for $0 \leq x \leq 6$

Jump table

```
.section .rodata
.align 4
.L7:
.long .L2 # x = 0
.long .L3 # x = 1
.long .L4 # x = 2
.long .L5 # x = 3
.long .L2 # x = 4
.long .L6 # x = 5
.long .L6 # x = 6
```

Jump Table

Jump table

```
.section .rodata
.align 4
.L7:
.long .L2 # x = 0
.long .L3 # x = 1
.long .L4 # x = 2
.long .L5 # x = 3
.long .L2 # x = 4
.long .L6 # x = 5
.long .L6 # x = 6
```

```
switch(x) {
case 1:      // .L3
    w = y*z;
    break;
case 2:      // .L4
    w = y/z;
    /* Fall Through */
case 3:      // .L5
    w += z;
    break;
case 5:
case 6:      // .L6
    w -= z;
    break;
default:    // .L2
    w = 2;
}
```

Handling Fall-Through

```
long w = 1;
. . .
switch(x) {
. . .
case 2:
    w = y/z;
    /* Fall Through */
case 3:
    w += z;
    break;
. . .
}
```

```
case 3:
    w = 1;
    goto merge;
```

```
case 2:
    w = y/z;
merge:
    w += z;
```

Code Blocks (Partial)

```

switch(x) {
case 1:          // .L3
    w = y*z;
    break;

    . . .
case 3:          // .L5
    w += z;
    break;

    . . .
default:        // .L2
    w = 2;
}

```

```

.L2:                # Default
    movl $2, %eax  # w = 2
    jmp  .L8       # Goto done

.L5:                # x == 3
    movl $1, %eax  # w = 1
    jmp  .L9       # Goto merge

.L3:                # x == 1
    movl 16(%ebp), %eax # z
    imull 12(%ebp), %eax # w = y*z
    jmp  .L8       # Goto done

```

Code Blocks (Rest)

```

switch(x) {
    . . .
    case 2: // .L4
        w = y/z;
        /* Fall Through */
merge:    // .L9
        w += z;
        break;
    case 5:
    case 6: // .L6
        w -= z;
        break;
}

```

```

.L4:                # x == 2
    movl 12(%ebp), %edx
    movl %edx, %eax
    sarl $31, %edx
    idivl 16(%ebp) # w = y/z

.L9:                # merge:
    addl 16(%ebp), %eax # w += z
    jmp  .L8         # goto done

.L6:                # x == 5, 6
    movl $1, %eax     # w = 1
    subl 16(%ebp), %eax # w = 1-z

```

Switch Code (Finish)

```
return w;
```

```
.L8:                                # done:  
    popl %ebp  
    ret
```

■ Noteworthy Features

- Jump table avoids sequencing through cases
 - Constant time, rather than linear
- Use jump table to handle holes and duplicate tags
- Use program sequencing to handle fall-through
- Don't initialize $w = 1$ unless really need it

x86-64 Switch Implementation

- Same general idea, adapted to 64-bit code
- Table entries 64 bits (pointers)
- Cases use revised code

```

switch(x) {
case 1:      // .L3
    w = y*z;
    break;
    . . .
}

```

```

.L3:
    movq    %rdx, %rax
    imulq   %rsi, %rax
    ret

```

Jump Table

```

.section .rodata
.align 8
.L7:
.quad    .L2      # x = 0
.quad    .L3      # x = 1
.quad    .L4      # x = 2
.quad    .L5      # x = 3
.quad    .L2      # x = 4
.quad    .L6      # x = 5
.quad    .L6      # x = 6

```

IA32 Object Code

■ Setup

- Label `.L2` becomes address `0x8048422`
- Label `.L7` becomes address `0x8048660`

Assembly Code

```
switch_eg:
    . . .
    ja     .L2          # If unsigned > goto default
    jmp    *.L7(,%eax,4) # Goto *JTab[x]
```

Disassembled Object Code

```
08048410 <switch_eg>:
    . . .
    8048419: 77 07                ja     8048422 <switch_eg+0x12>
    804841b: ff 24 85 60 86 04 08 jmp    *0x8048660(,%eax,4)
```

IA32 Object Code (cont.)

■ Jump Table

- Doesn't show up in disassembled code
- Can inspect using GDB
- `gdb switch`
- `(gdb) x/7xw 0x8048660`
 - Examine 7 hexadecimal format "words" (4-bytes each)
 - Use command "`help x`" to get format documentation

```
0x8048660:    0x08048422    0x08048432    0x0804843b    0x08048429
0x8048670:    0x08048422    0x0804844b    0x0804844b
```

IA32 Object Code (cont.)

■ Deciphering Jump Table

0x8048660: 0x08048422 0x08048432 0x0804843b 0x08048429
 0x8048670: 0x08048422 0x0804844b 0x0804844b

Address	Value	x
0x8048660	0x8048422	0
0x8048664	0x8048432	1
0x8048668	0x804843b	2
0x804866c	0x8048429	3
0x8048670	0x8048422	4
0x8048674	0x804844b	5
0x8048678	0x804844b	6

Disassembled Targets

```
8048422:  b8 02 00 00 00      mov     $0x2,%eax
8048427:  eb 2a              jmp     8048453 <switch_eg+0x43>
8048429:  b8 01 00 00 00      mov     $0x1,%eax
804842e:  66 90             xchg  %ax,%ax # noop
8048430:  eb 14              jmp     8048446 <switch_eg+0x36>
8048432:  8b 45 10           mov     0x10(%ebp),%eax
8048435:  0f af 45 0c       imul   0xc(%ebp),%eax
8048439:  eb 18              jmp     8048453 <switch_eg+0x43>
804843b:  8b 55 0c           mov     0xc(%ebp),%edx
804843e:  89 d0              mov     %edx,%eax
8048440:  c1 fa 1f           sar    $0x1f,%edx
8048443:  f7 7d 10           idivl  0x10(%ebp)
8048446:  03 45 10           add    0x10(%ebp),%eax
8048449:  eb 08              jmp     8048453 <switch_eg+0x43>
804844b:  b8 01 00 00 00      mov     $0x1,%eax
8048450:  2b 45 10           sub    0x10(%ebp),%eax
8048453:  5d                 pop    %ebp
8048454:  c3                 ret
```

Matching Disassembled Targets

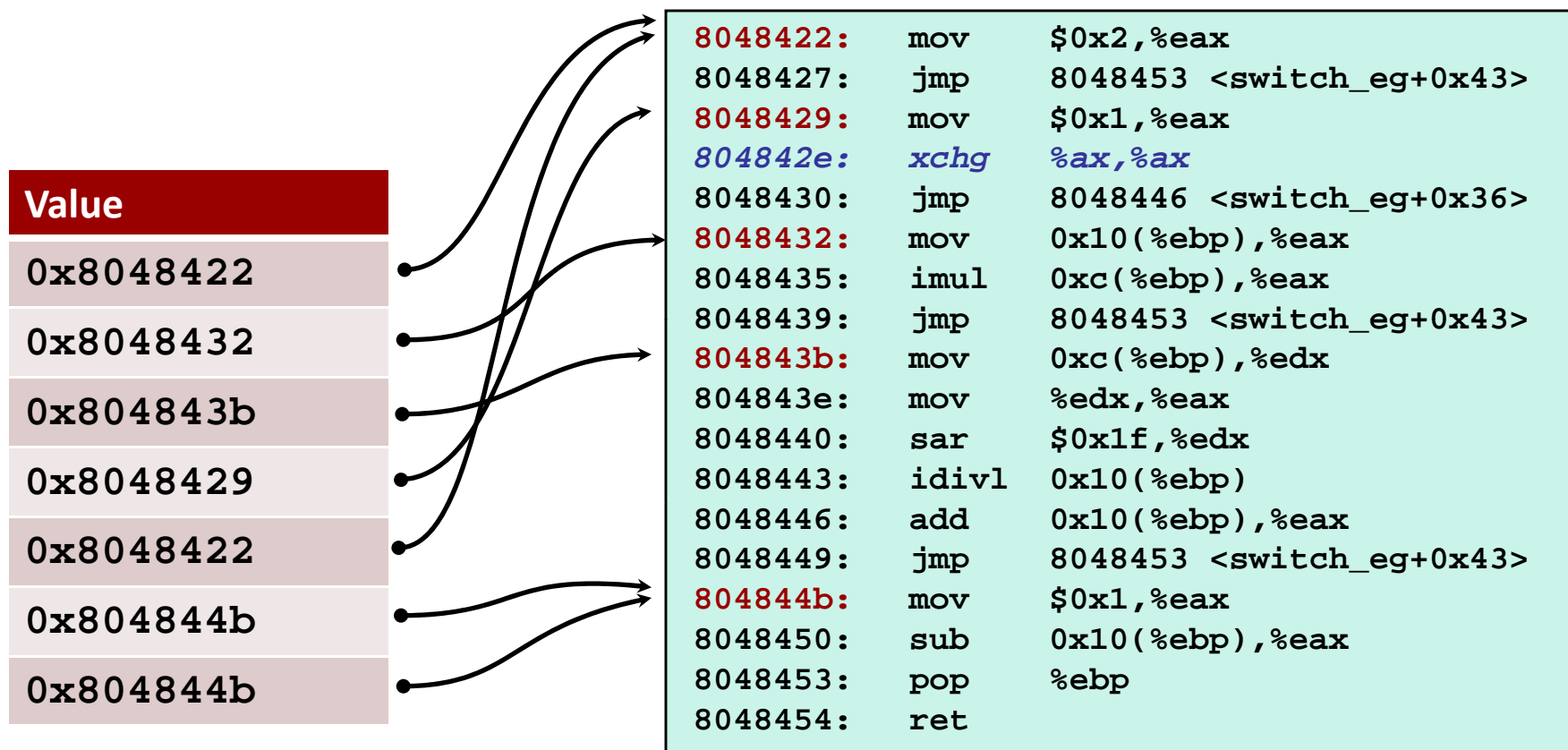

Summarizing

■ C Control

- if-then-else
- do-while
- while, for
- switch

■ Assembler Control

- Conditional jump
- Conditional move
- Indirect jump
- Compiler generates code sequence to implement more complex control

■ Standard Techniques

- Loops converted to do-while form
- Large switch statements use jump tables
- Sparse switch statements may use decision trees

Today

- Switch statements
- **IA 32 Procedures**
 - Stack Structure
 - Calling Conventions
 - Illustrations of Recursion & Pointers

IA32 Stack

- Region of memory managed with stack discipline
- Grows toward lower addresses
- Register `%esp` contains lowest stack address
 - address of “top” element

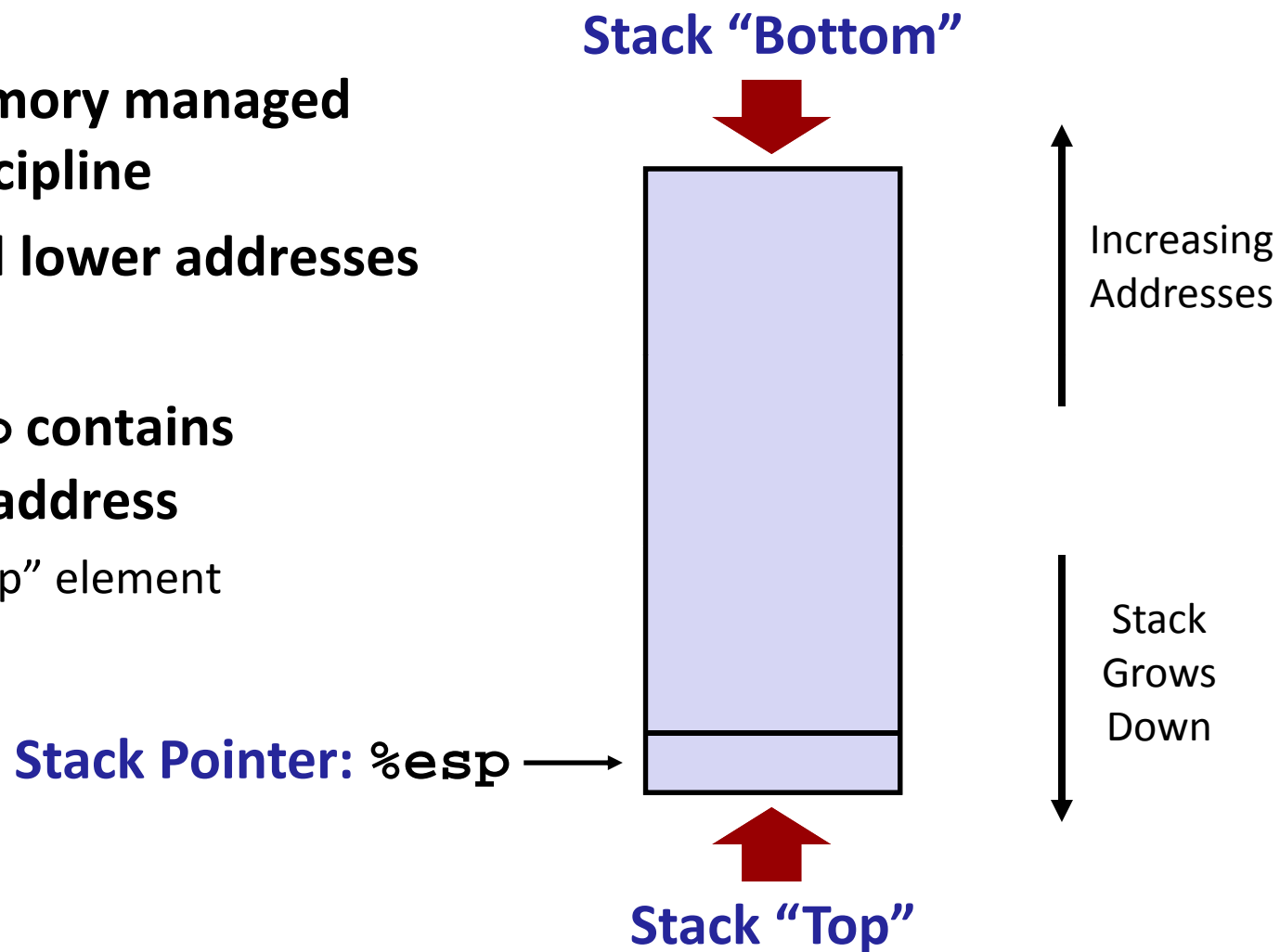

IA32 Stack: Push

■ `pushl Src`

- Fetch operand at *Src*
- Decrement `%esp` by 4
- Write operand at address given by `%esp`

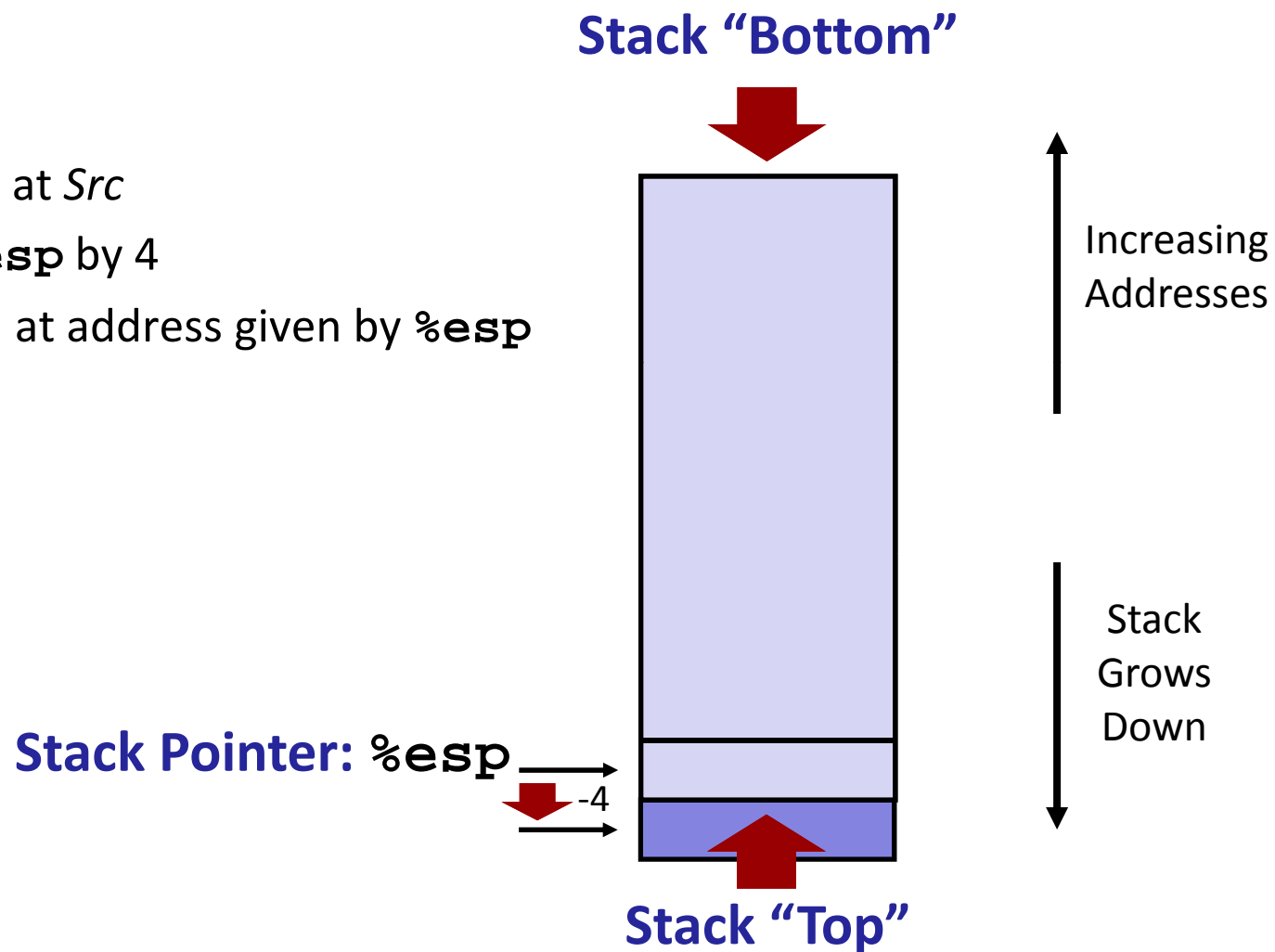

IA32 Stack: Pop

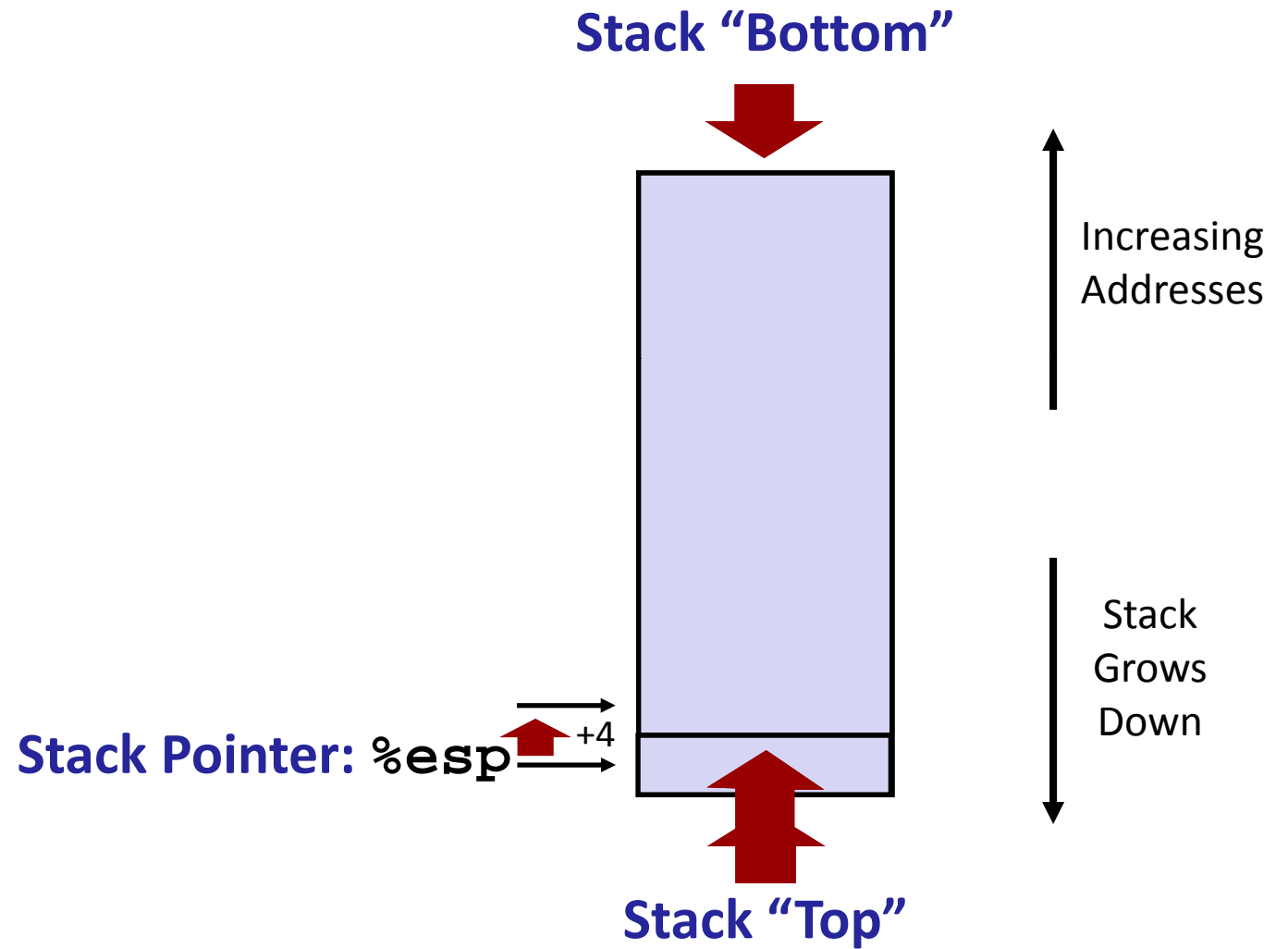

Procedure Control Flow

■ Use stack to support procedure call and return

■ Procedure call: `call label`

- Push return address on stack
- Jump to *label*

■ Return address:

- Address of the next instruction right after call
- Example from disassembly

```
804854e: e8 3d 06 00 00    call    8048b90 <main>
8048553: 50                pushl   %eax
```

- Return address = `0x8048553`

■ Procedure return: `ret`

- Pop address from stack
- Jump to address

Procedure Call Example

```
804854e:    e8 3d 06 00 00    call   8048b90 <main>
8048553:    50               pushl  %eax
```

call 8048b90

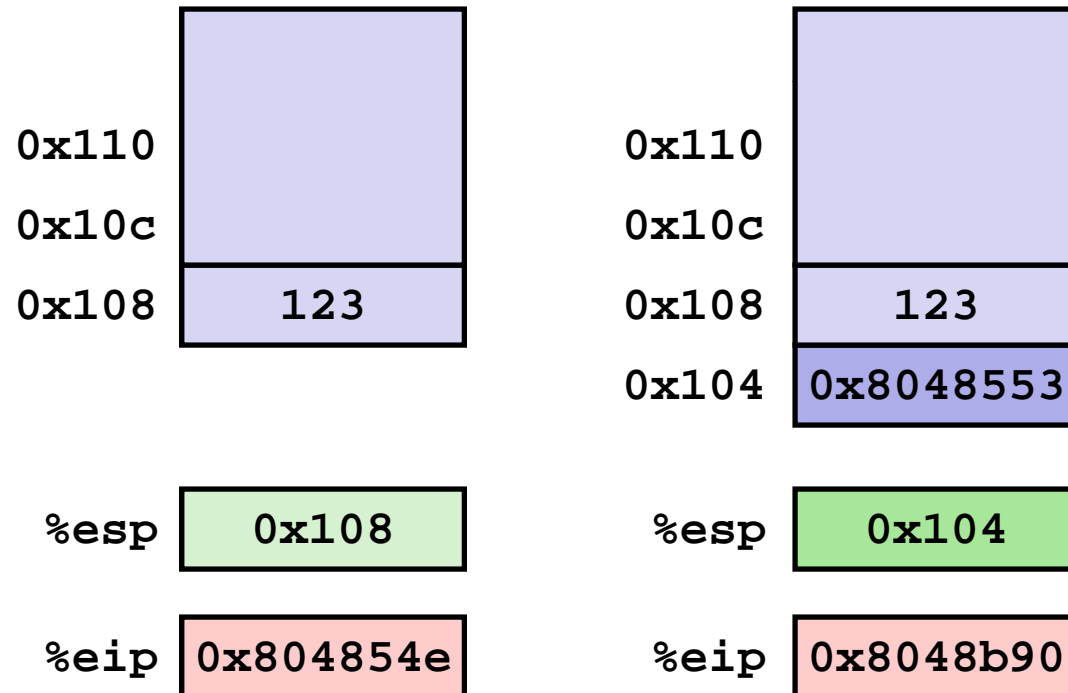

%eip: program counter

Procedure Return Example

```
8048591:    c3                ret
```

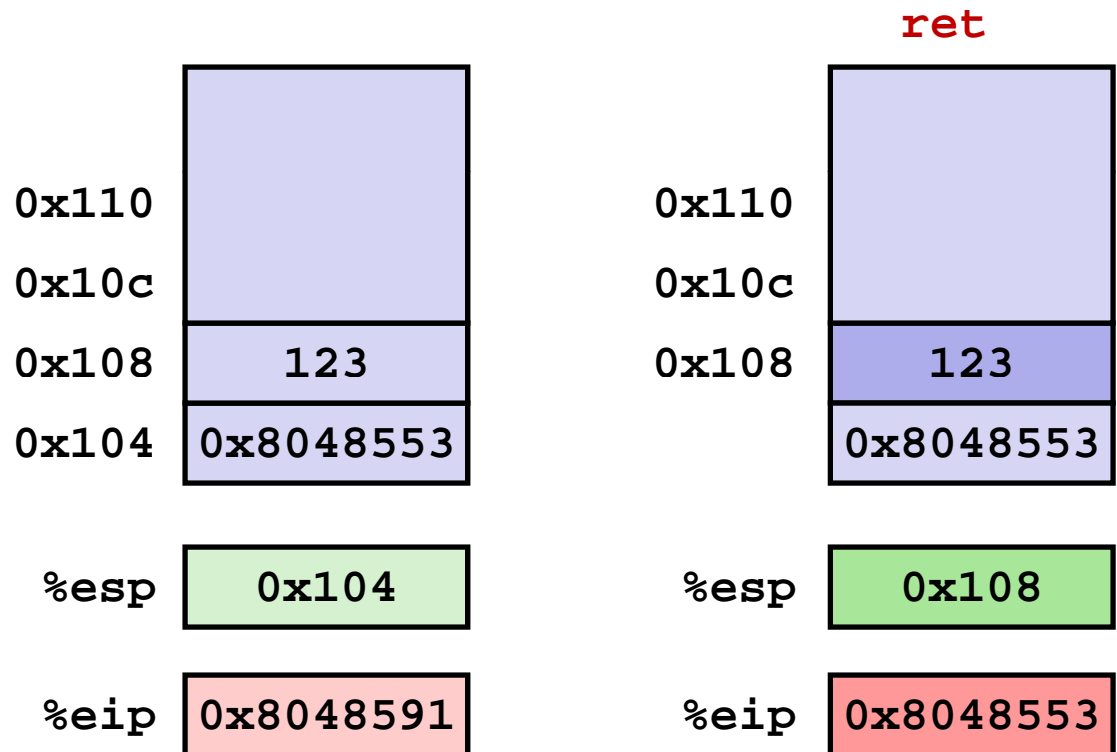

`%eip`: program counter

Stack-Based Languages

■ Languages that support recursion

- e.g., C, Pascal, Java
- Code must be “*Reentrant*”
 - Multiple simultaneous instantiations of single procedure
- Need some place to store state of each instantiation
 - Arguments
 - Local variables
 - Return pointer

■ Stack discipline

- State for given procedure needed for limited time
 - From when called to when return
- Callee returns before caller does

■ Stack allocated in *Frames*

- state for single procedure instantiation

Call Chain Example

```

yoo(...)
{
  .
  .
  who();
  .
  .
}

```

```

who(...)
{
  . . .
  amI();
  . . .
  amI();
  . . .
}

```

```

amI(...)
{
  .
  .
  amI();
  .
  .
}

```

Procedure `amI()` is recursive

Example Call Chain

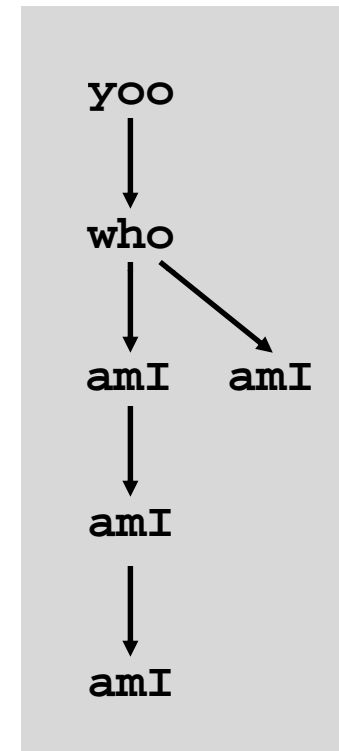

Stack Frames

■ Contents

- Local variables
- Return information
- Temporary space

■ Management

- Space allocated when enter procedure
 - “Set-up” code
- Deallocated when return
 - “Finish” code

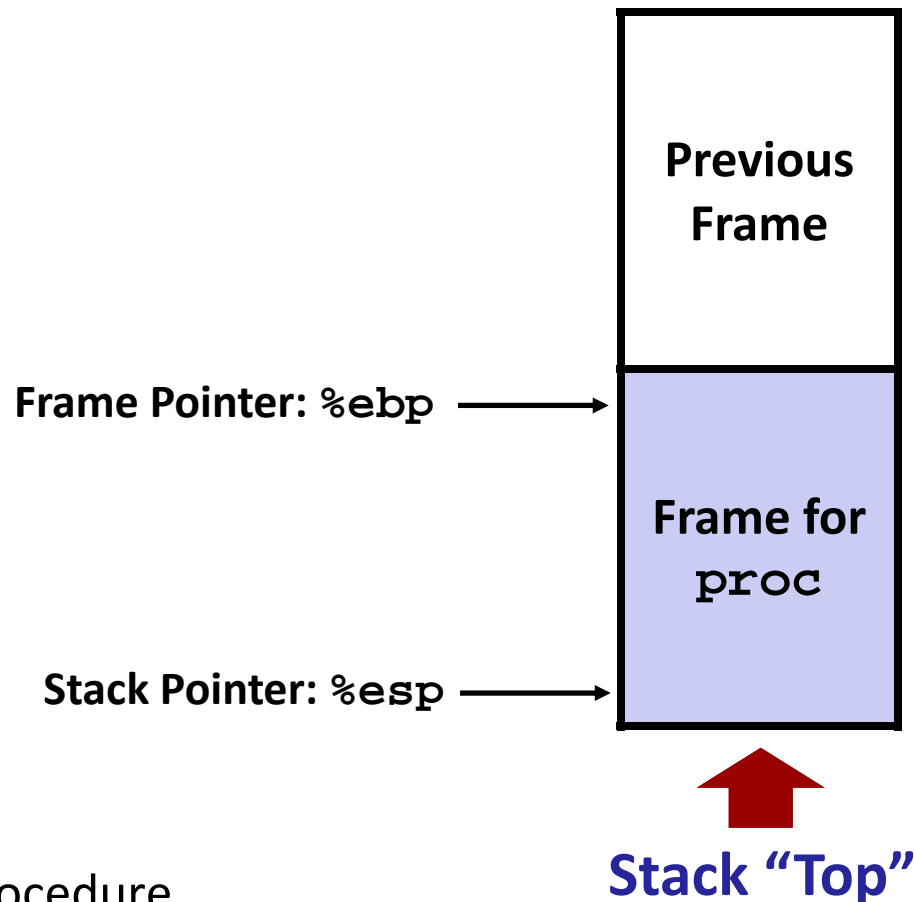

Example

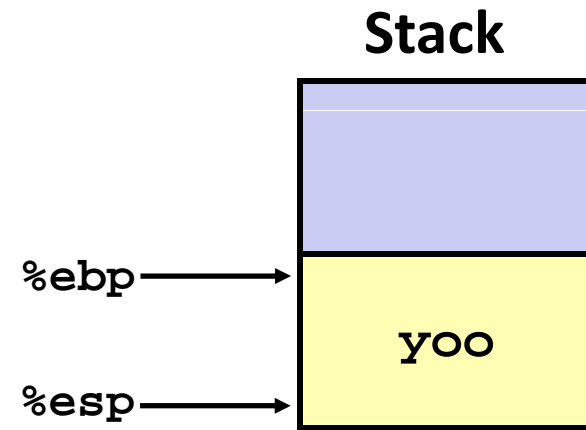
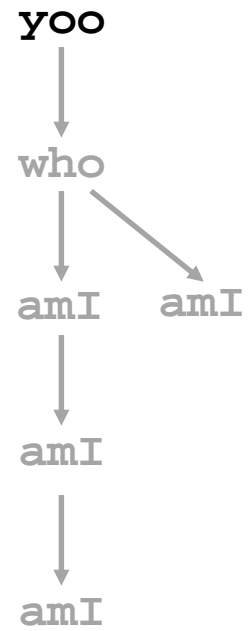
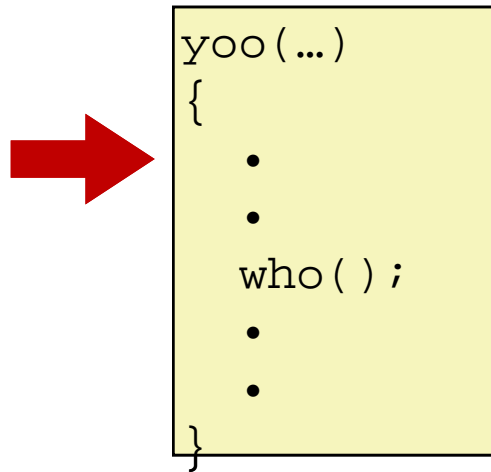

Example

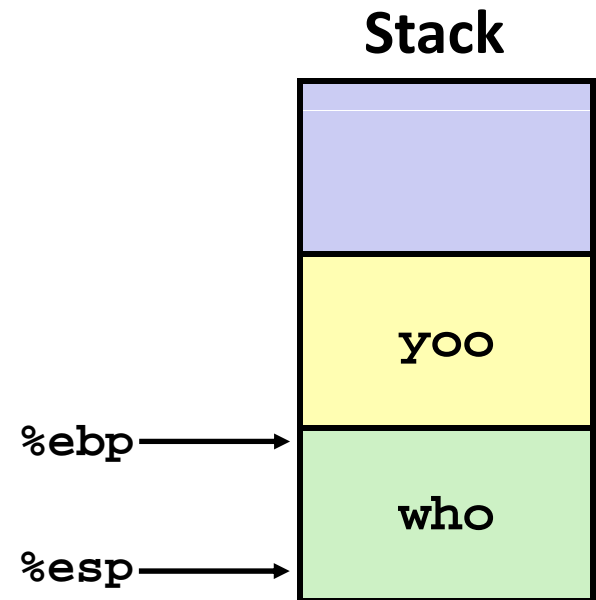
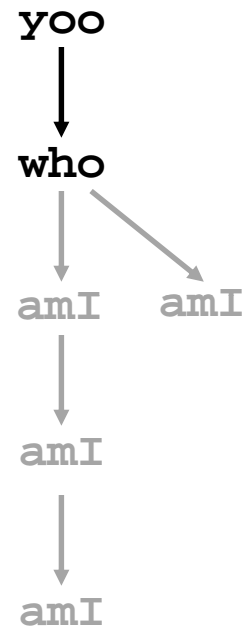
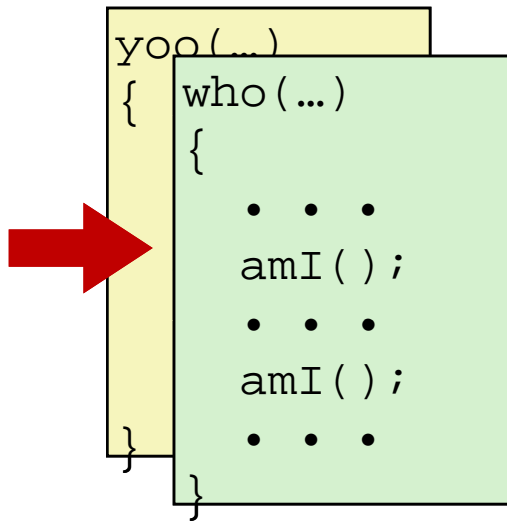

Example

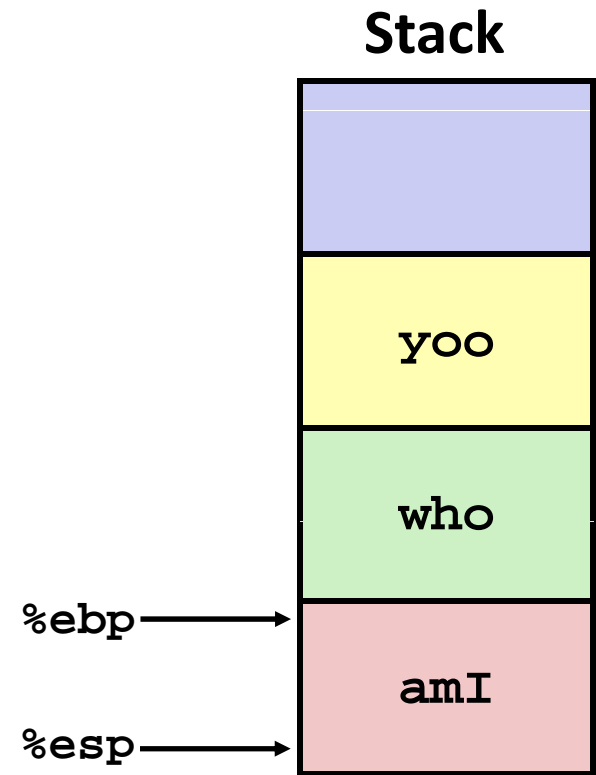
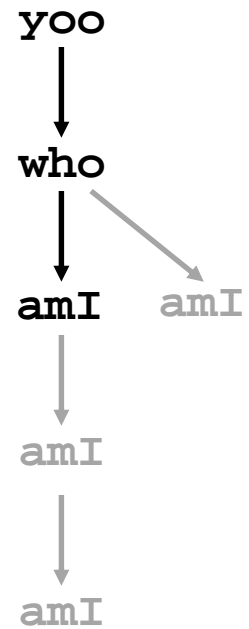
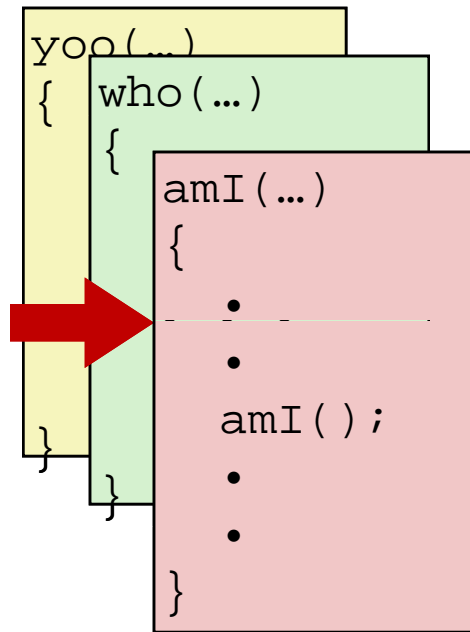

Example

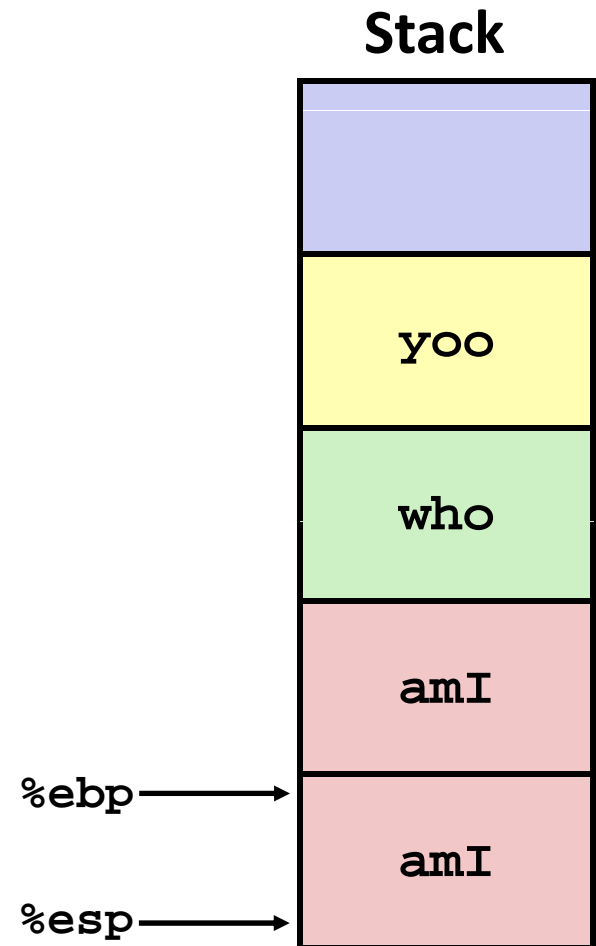
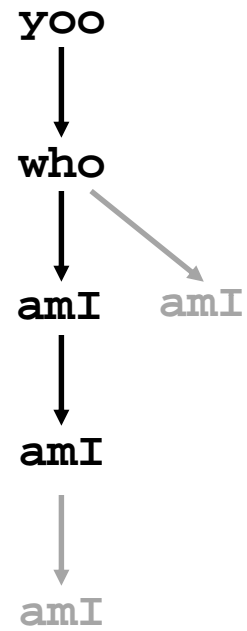
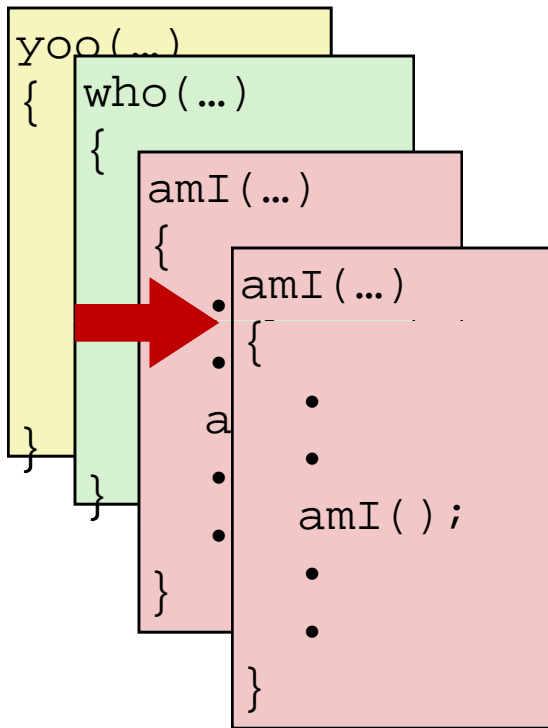

Example

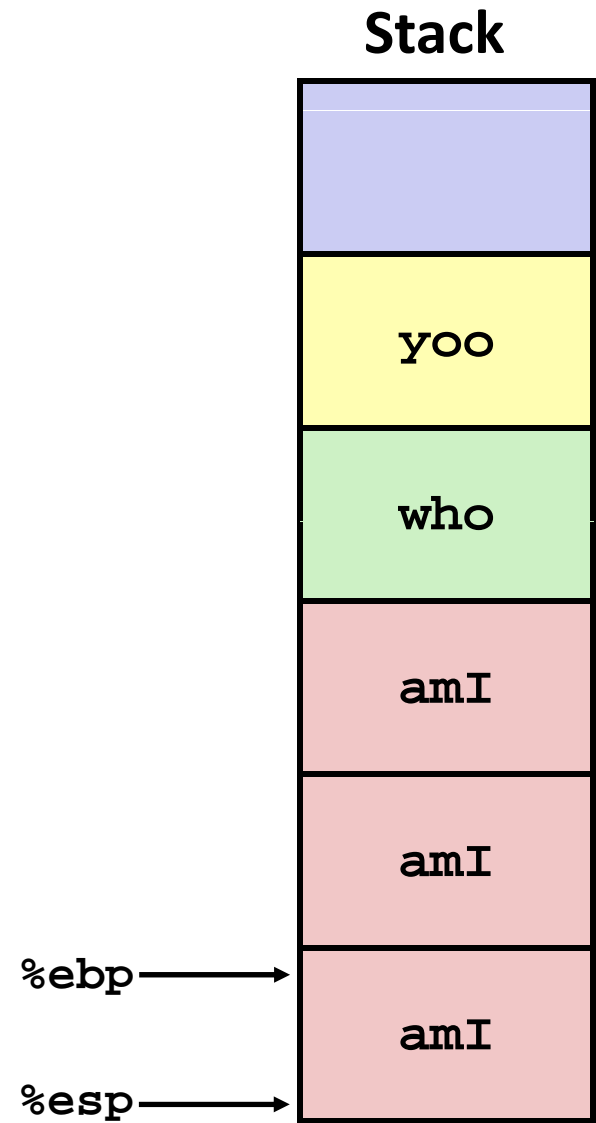
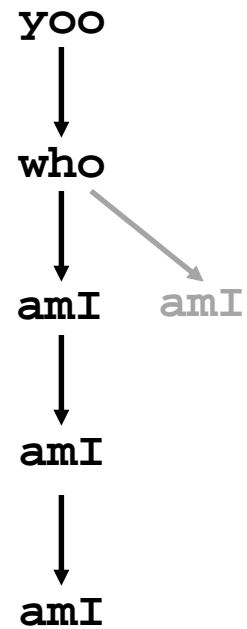
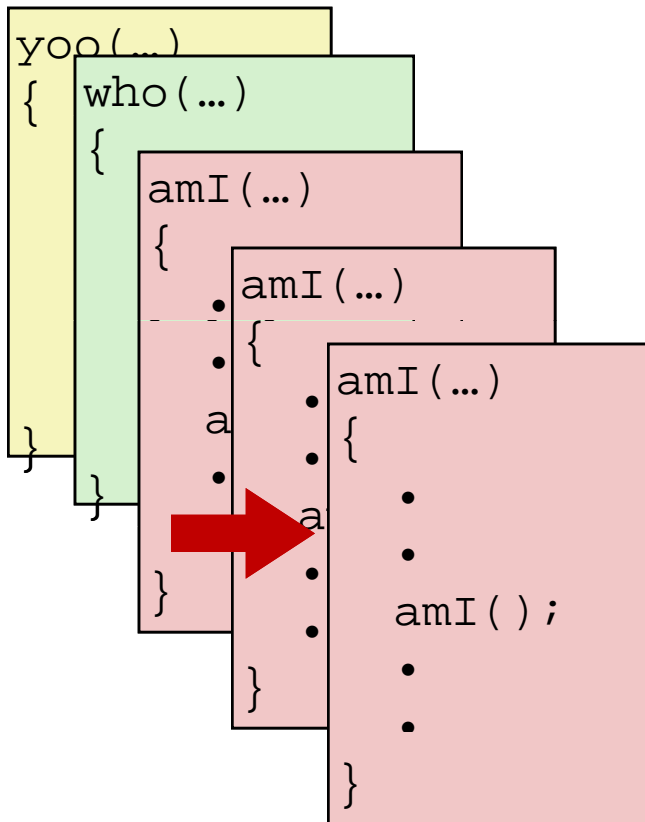

Example

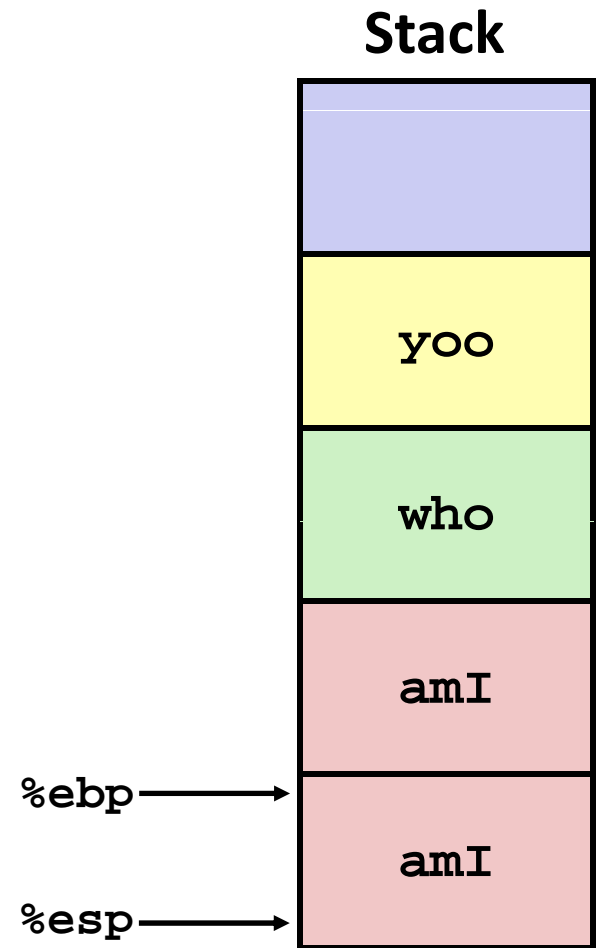
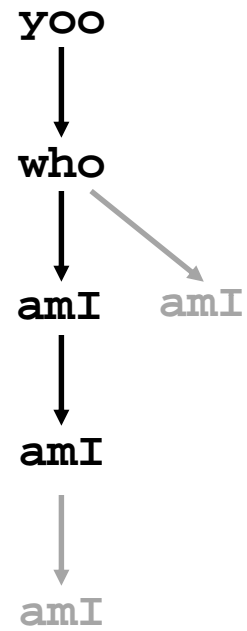
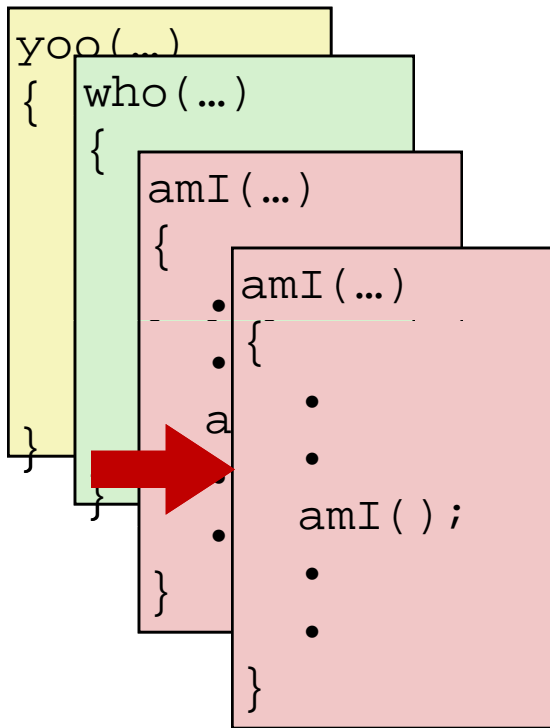

Example

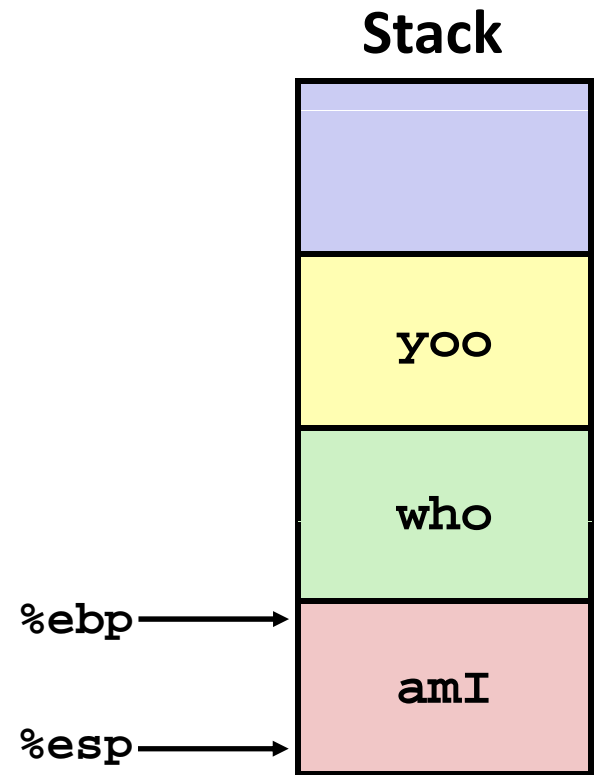
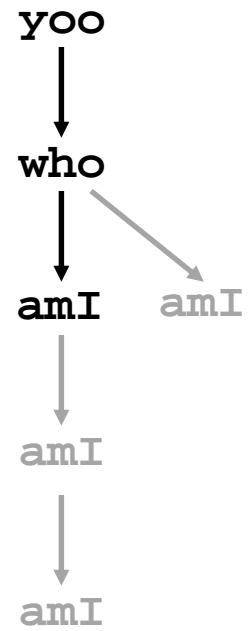
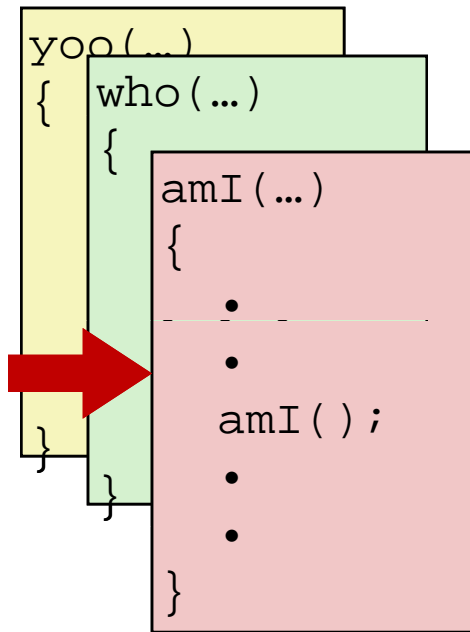

Example

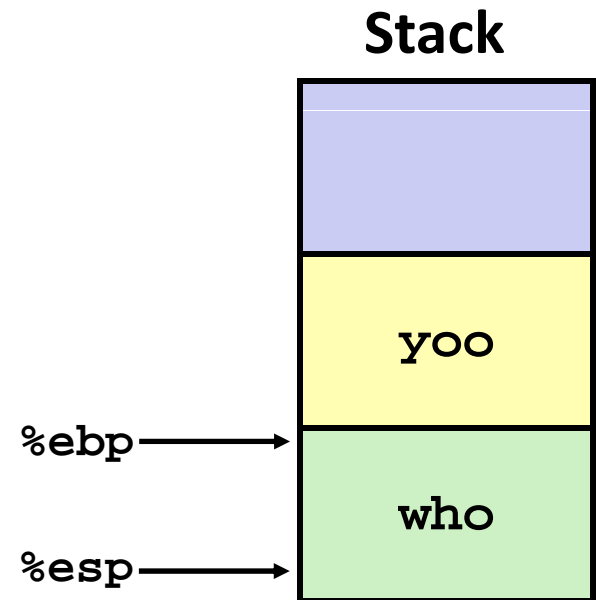
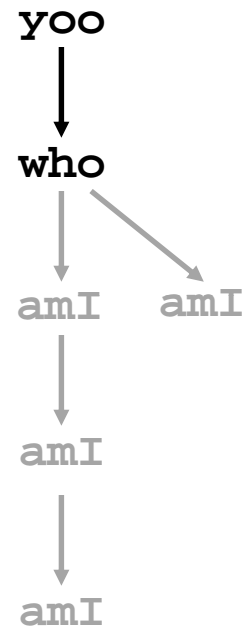
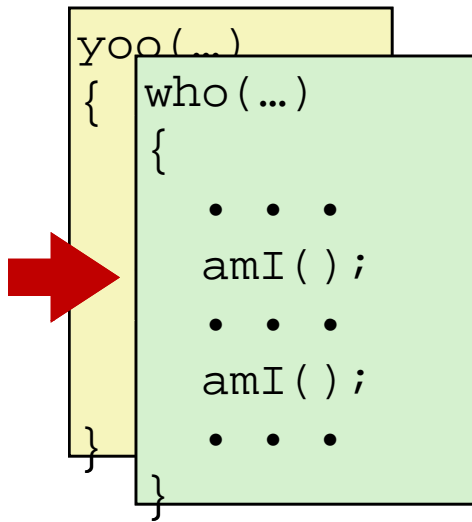

Example

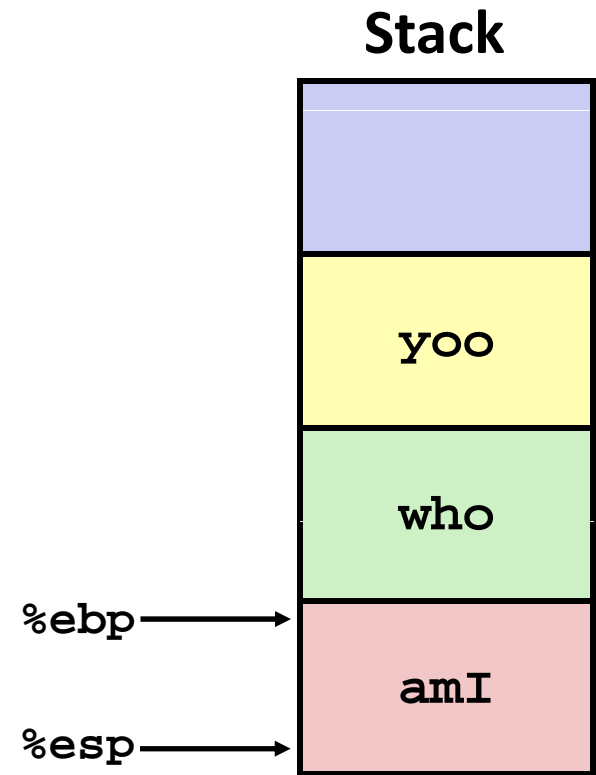
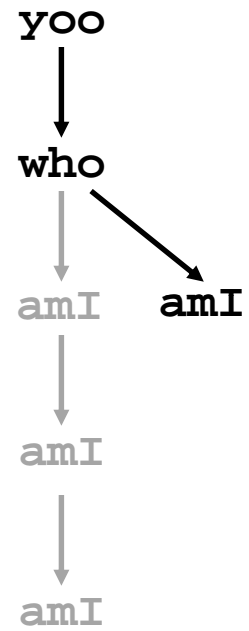
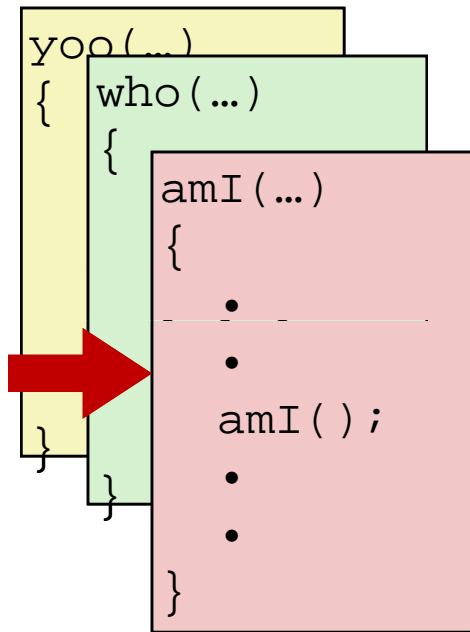

Example

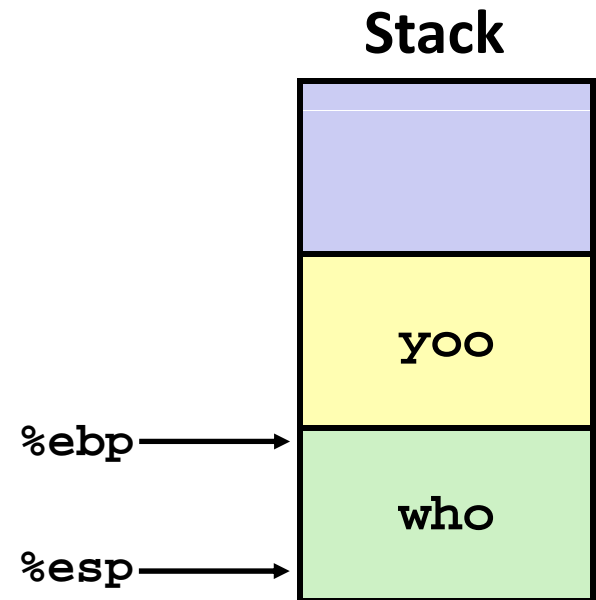
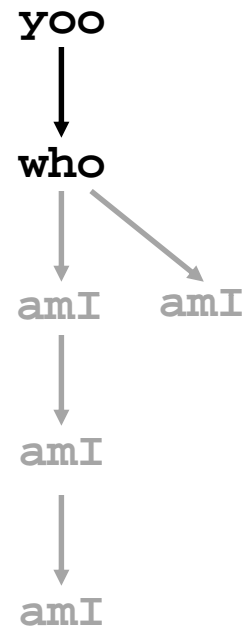
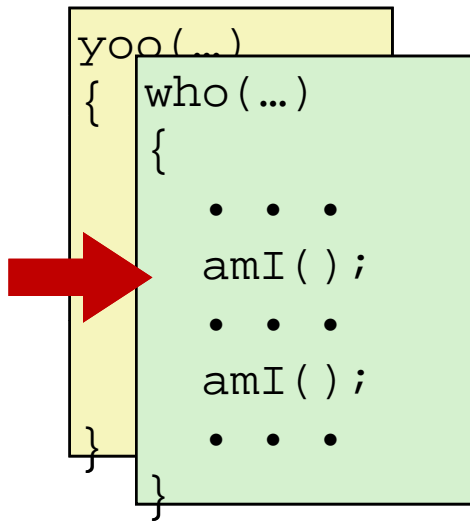

Example

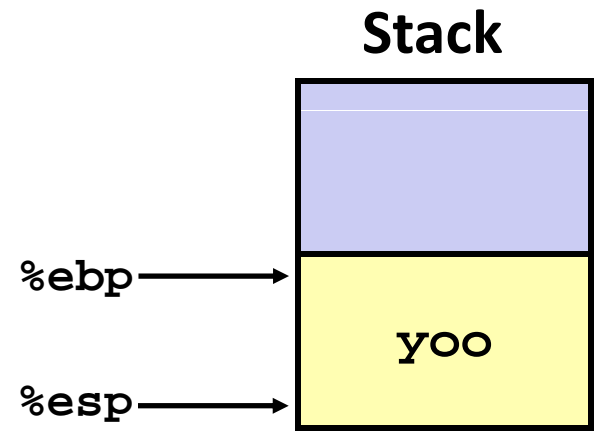
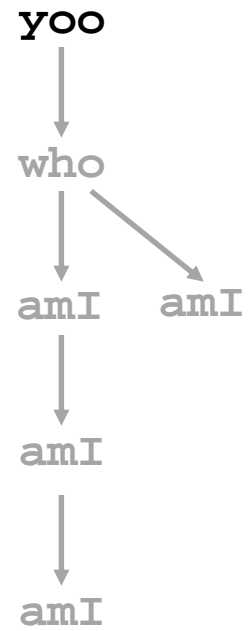
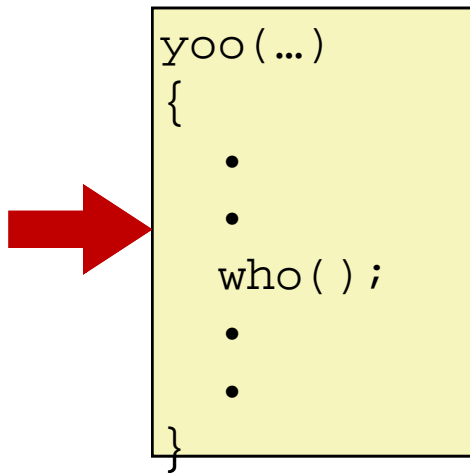

IA32/Linux Stack Frame

■ Current Stack Frame (“Top” to Bottom)

- “Argument build:”
Parameters for function about to call
- Local variables
If can’t keep in registers
- Saved register context
- Old frame pointer

■ Caller Stack Frame

- Return address
 - Pushed by `call` instruction
- Arguments for this call

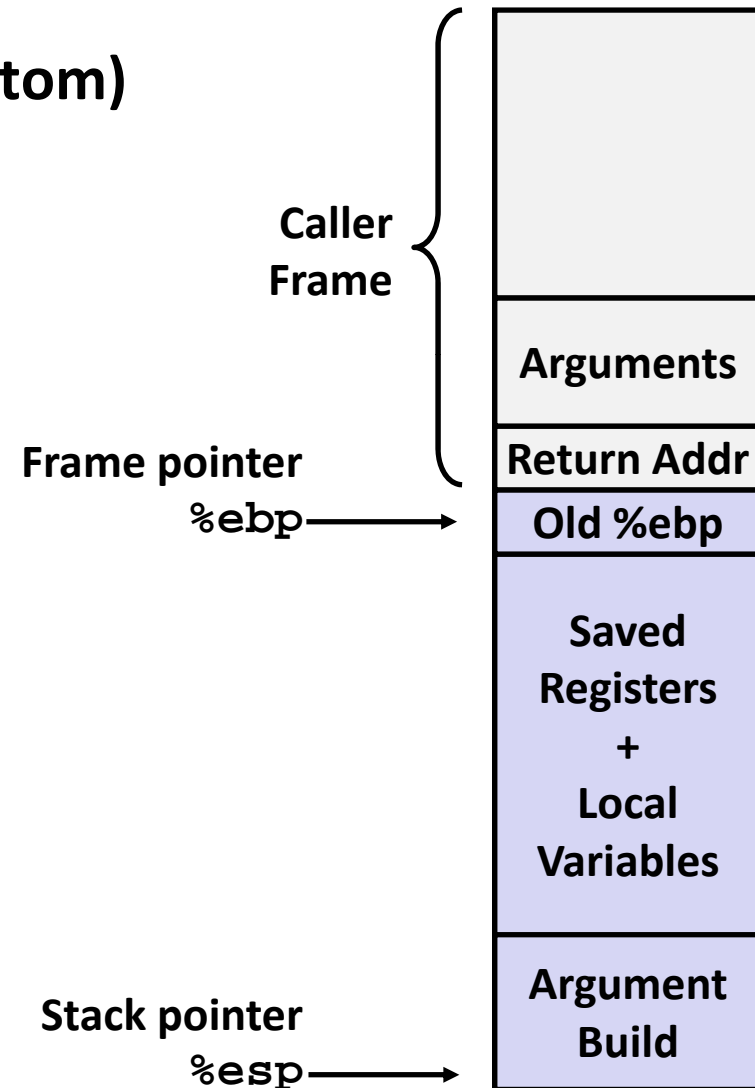

Revisiting swap

```
int course1 = 15213;
int course2 = 18243;

void call_swap() {
    swap(&course1, &course2);
}
```

```
void swap(int *xp, int *yp)
{
    int t0 = *xp;
    int t1 = *yp;
    *xp = t1;
    *yp = t0;
}
```

Calling swap from call_swap

```
call_swap:
    . . .
    subl    $8, %esp
    movl    $course2, 4(%esp)
    movl    $course1, (%esp)
    call    swap
    . . .
```

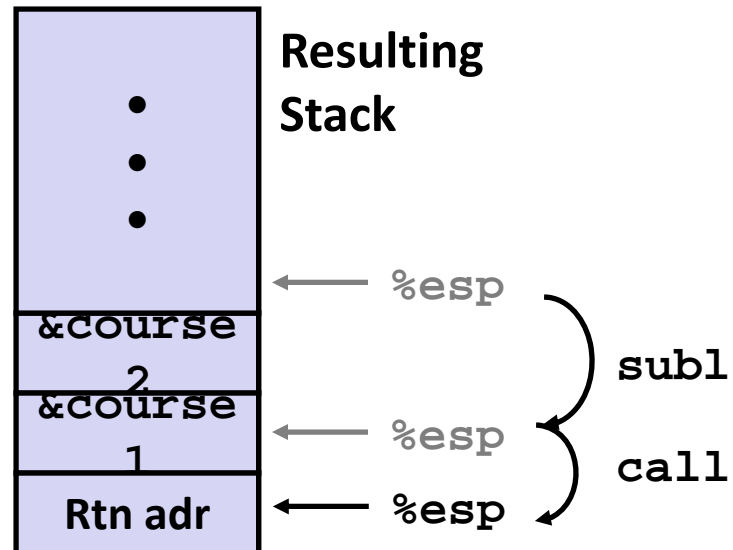

Revisiting swap

```
void swap(int *xp, int *yp)
{
    int t0 = *xp;
    int t1 = *yp;
    *xp = t1;
    *yp = t0;
}
```

swap:

```

    pushl %ebp
    movl  %esp, %ebp
    pushl %ebx
} Set Up

    movl  8(%ebp), %edx
    movl  12(%ebp), %ecx
    movl  (%edx), %ebx
    movl  (%ecx), %eax
    movl  %eax, (%edx)
    movl  %ebx, (%ecx)
} Body

    popl  %ebx
    popl  %ebp
    ret
} Finish
```

swap Setup #1

Entering Stack

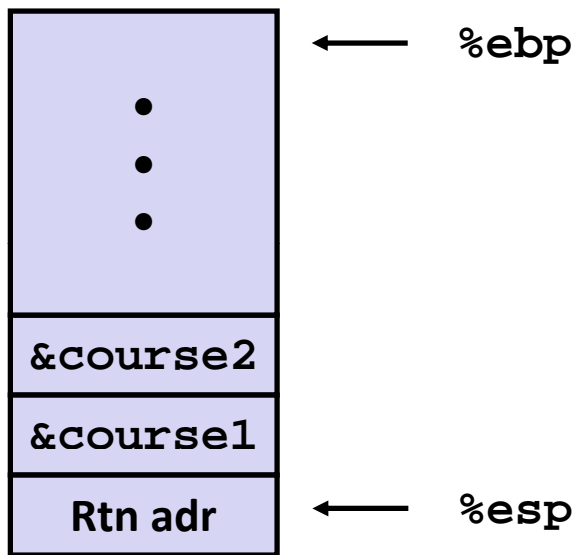

Resulting Stack

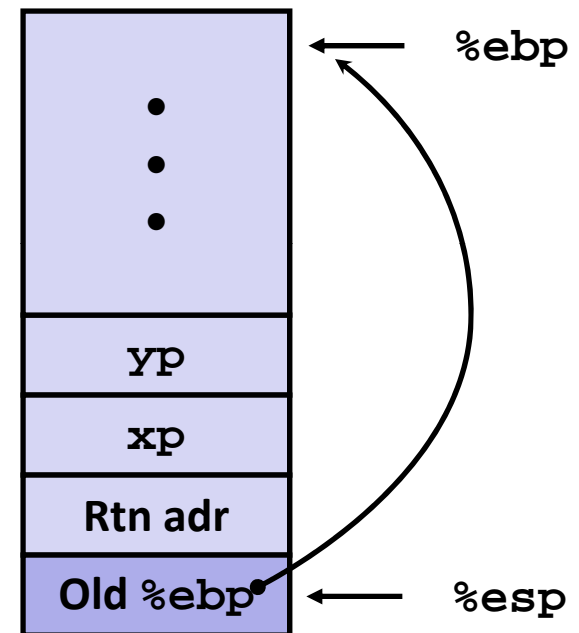

`swap:`

```

pushl %ebp
movl %esp,%ebp
pushl %ebx

```

swap Setup #2

Entering Stack

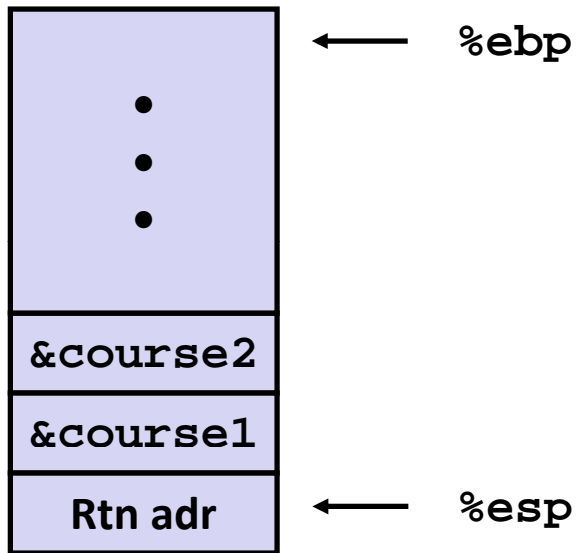

Resulting Stack

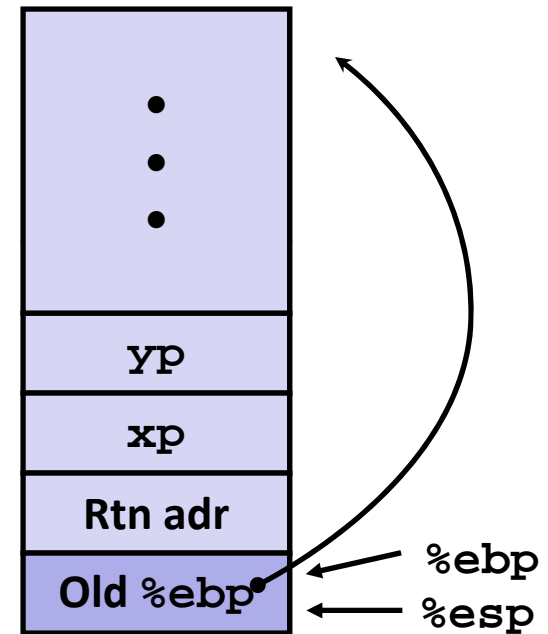

`swap:`

```

pushl %ebp
movl %esp,%ebp
pushl %ebx

```

swap Setup #3

Entering Stack

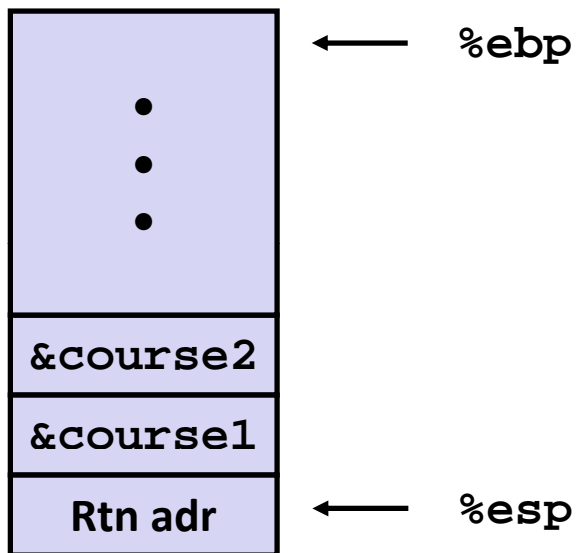

Resulting Stack

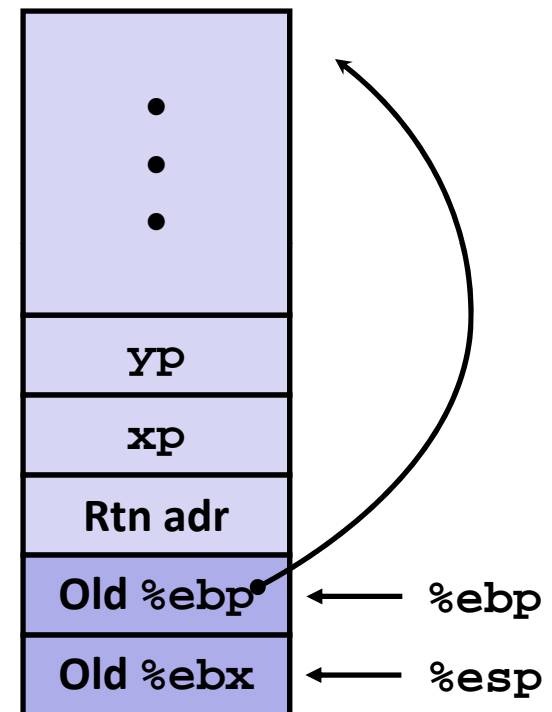

`swap:`

```

pushl %ebp
movl %esp,%ebp
pushl %ebx

```

swap Body

Entering Stack

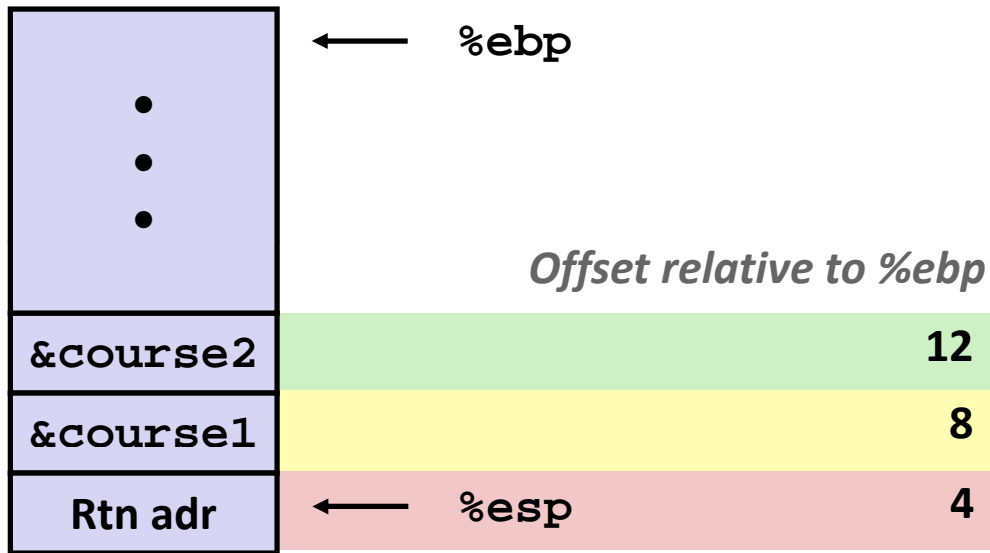

Resulting Stack

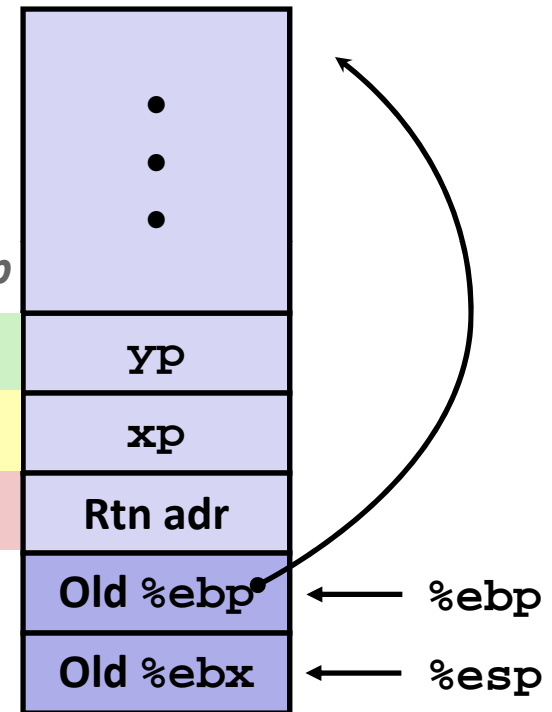

```

movl 8(%ebp),%edx    # get xp
movl 12(%ebp),%ecx   # get yp
. . .

```

swap Finish

Stack Before Finish

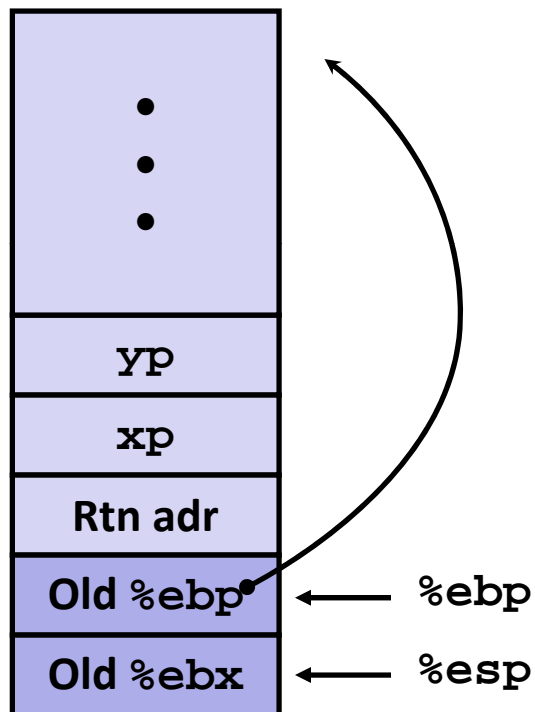

```
popl %ebx
popl %ebp
```

Resulting Stack

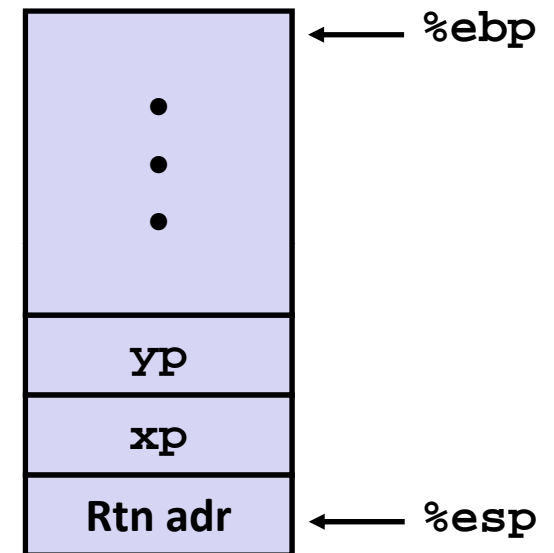

■ Observation

- Saved and restored register **%ebx**
- Not so for **%eax, %ecx, %edx**

Disassembled swap

08048384 <swap>:

8048384:	55	push	%ebp
8048385:	89 e5	mov	%esp,%ebp
8048387:	53	push	%ebx
8048388:	8b 55 08	mov	0x8(%ebp),%edx
804838b:	8b 4d 0c	mov	0xc(%ebp),%ecx
804838e:	8b 1a	mov	(%edx),%ebx
8048390:	8b 01	mov	(%ecx),%eax
8048392:	89 02	mov	%eax,(%edx)
8048394:	89 19	mov	%ebx,(%ecx)
8048396:	5b	pop	%ebx
8048397:	5d	pop	%ebp
8048398:	c3	ret	

Calling Code

80483b4:	movl	\$0x8049658,0x4(%esp)	# Copy &course2
80483bc:	movl	\$0x8049654,(%esp)	# Copy &course1
80483c3:	call	8048384 <swap>	# Call swap
80483c8:	leave		# Prepare to return
80483c9:	ret		# Return

Today

- Switch statements
- **IA 32 Procedures**
 - Stack Structure
 - Calling Conventions
 - Illustrations of Recursion & Pointers

Register Saving Conventions

■ When procedure `yoo` calls `who`:

- `yoo` is the *caller*
- `who` is the *callee*

■ Can register be used for temporary storage?

```
yoo:
    . . .
    movl $15213, %edx
    call who
    addl %edx, %eax
    . . .
    ret
```

```
who:
    . . .
    movl 8(%ebp), %edx
    addl $18243, %edx
    . . .
    ret
```

- Contents of register `%edx` overwritten by `who`
- This could be trouble → something should be done!
 - Need some coordination

Register Saving Conventions

- When procedure `yoo` calls `who`:
 - `yoo` is the *caller*
 - `who` is the *callee*
- Can register be used for temporary storage?
- Conventions
 - *“Caller Save”*
 - Caller saves temporary values in its frame before the call
 - *“Callee Save”*
 - Callee saves temporary values in its frame before using

IA32/Linux+Windows Register Usage

- **%eax, %edx, %ecx**
 - Caller saves prior to call if values are used later
- **%eax**
 - also used to return integer value
- **%ebx, %esi, %edi**
 - Callee saves if wants to use them
- **%esp, %ebp**
 - special form of callee save
 - Restored to original values upon exit from procedure

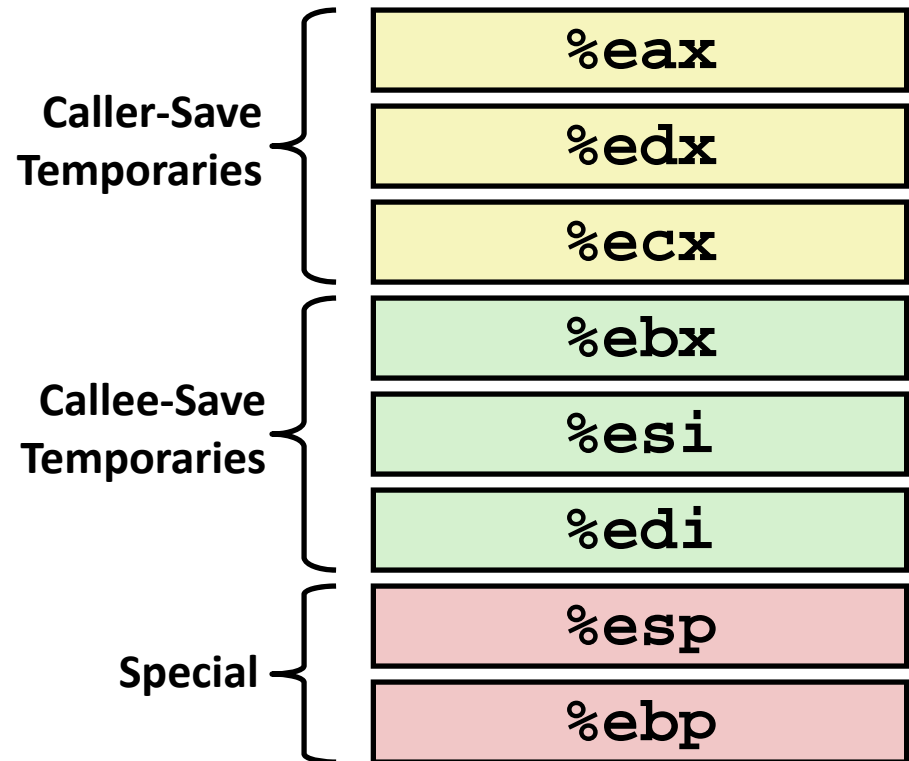

Today

- Switch statements
- **IA 32 Procedures**
 - Stack Structure
 - Calling Conventions
 - Illustrations of Recursion & Pointers

Recursive Function

```

/* Recursive popcount */
int pcount_r(unsigned x) {
    if (x == 0)
        return 0;
    else return
        (x & 1) + pcount_r(x >> 1);
}

```

■ Registers

- `%eax, %edx` used without first saving
- `%ebx` used, but saved at beginning & restored at end

```

pcount_r:
    pushl %ebp
    movl  %esp, %ebp
    pushl %ebx
    subl  $4, %esp
    movl  8(%ebp), %ebx
    movl  $0, %eax
    testl %ebx, %ebx
    je   .L3
    movl  %ebx, %eax
    shrl  %eax
    movl  %eax, (%esp)
    call pcount_r
    movl  %ebx, %edx
    andl  $1, %edx
    leal  (%edx,%eax), %eax
.L3:
    addl  $4, %esp
    popl  %ebx
    popl  %ebp
    ret

```

Recursive Call #1

```

/* Recursive popcount */
int pcount_r(unsigned x) {
    if (x == 0)
        return 0;
    else return
        (x & 1) + pcount_r(x >> 1);
}

```

■ Actions

- Save old value of `%ebx` on stack
- Allocate space for argument to recursive call
- Store `x` in `%ebx`

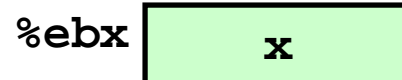

```

pcount_r:
    pushl %ebp
    movl  %esp, %ebp
    pushl %ebx
    subl  $4, %esp
    movl  8(%ebp), %ebx
    . . .

```

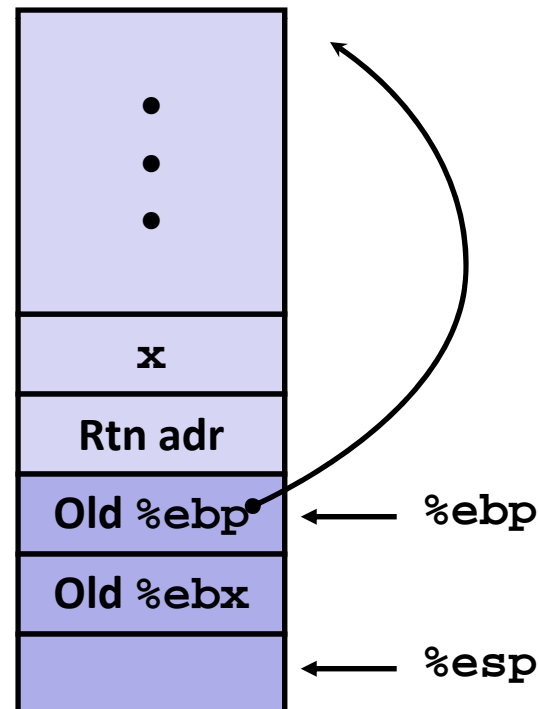

Recursive Call #2

```

/* Recursive popcount */
int pcount_r(unsigned x) {
    if (x == 0)
        return 0;
    else return
        (x & 1) + pcount_r(x >> 1);
}

```

```

    • • •
    movl  $0, %eax
    testl %ebx, %ebx
    je   .L3
    • • •
.L3:
    • • •
    ret

```

■ Actions

- If `x == 0`, return
 - with `%eax` set to 0

`%ebx`

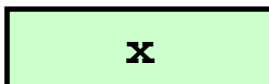

Recursive Call #3

```

/* Recursive popcount */
int pcount_r(unsigned x) {
    if (x == 0)
        return 0;
    else return
        (x & 1) + pcount_r(x >> 1);
}

```

■ Actions

- Store $x \gg 1$ on stack
- Make recursive call

■ Effect

- $\%eax$ set to function result
- $\%ebx$ still has value of x

$\%ebx$ x

```

• • •
movl  %ebx, %eax
shrl  %eax
movl  %eax, (%esp)
call  pcount_r
• • •

```

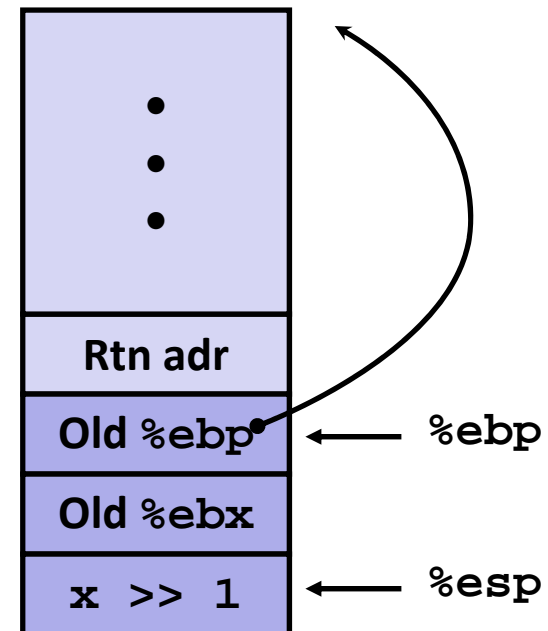

Recursive Call #4

```

/* Recursive popcount */
int pcount_r(unsigned x) {
    if (x == 0)
        return 0;
    else return
        (x & 1) + pcount_r(x >> 1);
}

```

```

• • •
movl    %ebx, %edx
andl    $1, %edx
leal    (%edx,%eax), %eax
• • •

```

■ Assume

- %eax holds value from recursive call
- %ebx holds x

■ Actions

- Compute $(x \& 1) +$ computed value

■ Effect

- %eax set to function result

%ebx x

Recursive Call #5

```

/* Recursive popcount */
int pcount_r(unsigned x) {
    if (x == 0)
        return 0;
    else return
        (x & 1) + pcount_r(x >> 1);
}

```

```

• • •
L3:
    addl$4, %esp
    popl%ebx
    popl%ebp
    ret

```

■ Actions

- Restore values of %ebx and %ebp
- Restore %esp

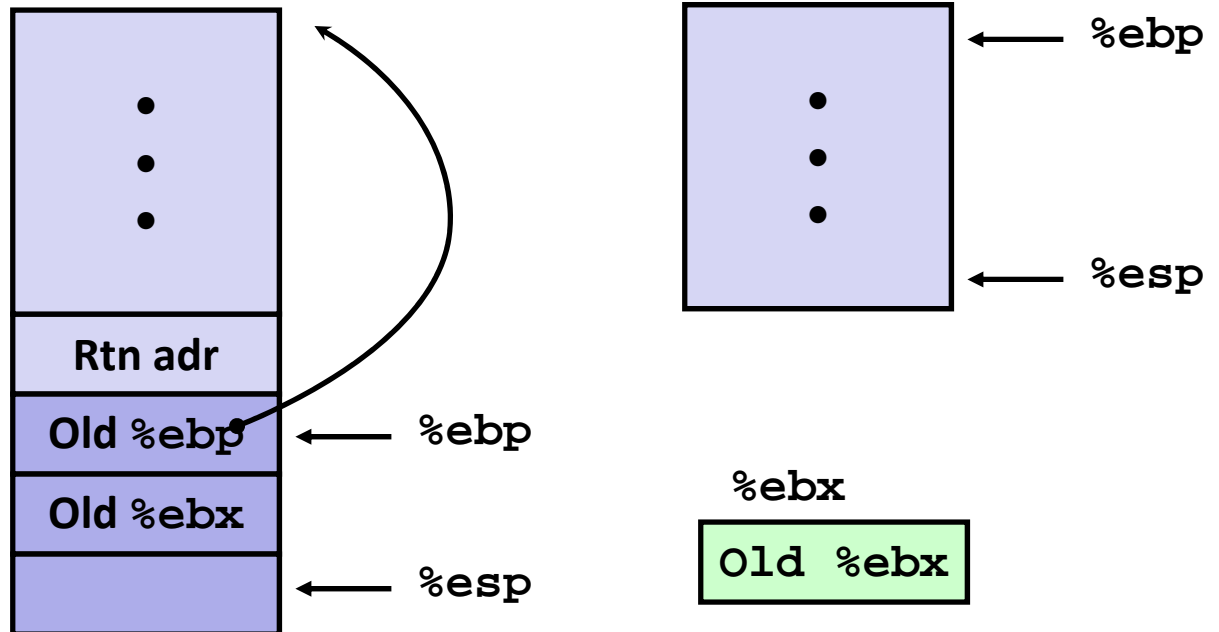

Observations About Recursion

■ Handled Without Special Consideration

- Stack frames mean that each function call has private storage
 - Saved registers & local variables
 - Saved return pointer
- Register saving conventions prevent one function call from corrupting another's data
- Stack discipline follows call / return pattern
 - If P calls Q, then Q returns before P
 - Last-In, First-Out

■ Also works for mutual recursion

- P calls Q; Q calls P

Pointer Code

Generating Pointer

```
/* Compute x + 3 */  
int add3(int x) {  
    int localx = x;  
    incrk(&localx, 3);  
    return localx;  
}
```

Referencing Pointer

```
/* Increment value by k */  
void incrk(int *ip, int k) {  
    *ip += k;  
}
```

- **add3** creates pointer and passes it to **incrk**

Creating and Initializing Local Variable

```
int add3(int x) {
    int localx = x;
    incrk(&localx, 3);
    return localx;
}
```

- Variable localx must be stored on stack
 - Because: Need to create pointer to it
- Compute pointer as $-4(\%ebp)$

First part of add3

```
add3:
    pushl %ebp
    movl %esp, %ebp
    subl $24, %esp      # Alloc. 24 bytes
    movl 8(%ebp), %eax
    movl %eax, -4(%ebp) # Set localx to x
```

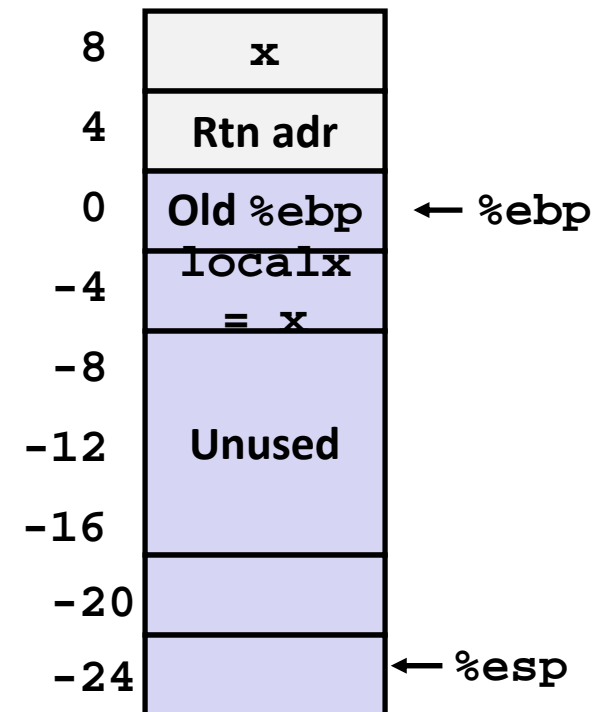

Creating Pointer as Argument

```
int add3(int x) {
    int localx = x;
    incrk(&localx, 3);
    return localx;
}
```

- Use leal instruction to compute address of localx

Middle part of add3

```
movl $3, 4(%esp)    # 2nd arg = 3
leal -4(%ebp), %eax # &localx
movl %eax, (%esp)   # 1st arg = &localx
call incrk
```

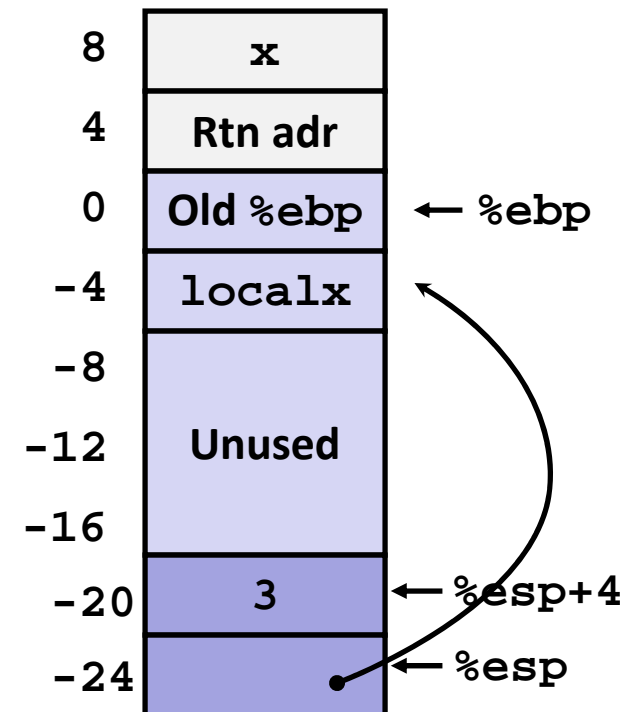

Retrieving local variable

```
int add3(int x) {
    int localx = x;
    incrk(&localx, 3);
    return localx;
}
```

- Retrieve localx from stack as return value

Final part of add3

```
movl -4(%ebp), %eax # Return val= localx
leave
ret
```

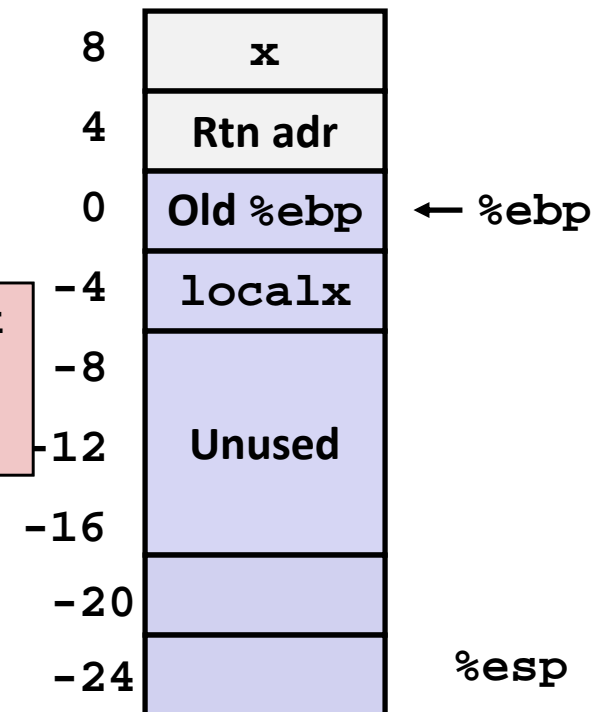

IA 32 Procedure Summary

■ Important Points

- Stack is the right data structure for procedure call / return
 - If P calls Q, then Q returns before P

■ Recursion (& mutual recursion) handled by normal calling conventions

- Can safely store values in local stack frame and in callee-saved registers
- Put function arguments at top of stack
- Result return in `%eax`

■ Pointers are addresses of values

- On stack or global

