



10-301/10-601 Introduction to Machine Learning

Machine Learning Department
School of Computer Science
Carnegie Mellon University

Neural Networks

Matt Gormley & Geoff Gordon

Lecture 11

Sep. 29, 2025

Reminders

- **Exam 1: today, 7pm – 9pm, see Piazza for details**
- **Homework 4: Logistic Regression**
 - **Out: Mon, Sep 29**
 - **Due: Wed, Oct 8 at 11:59pm**

A RECIPE FOR ML

A Recipe for Machine Learning

1. Given training data:

$$\mathcal{D} = \{\mathbf{x}^{(i)}, y^{(i)}\}_{i=1}^N$$

2. Choose each of these:

- Decision function

$$\hat{y} = h_{\theta}(\mathbf{x})$$

- Loss function

$$\ell(\hat{y}, y) \in \mathbb{R}$$

Face



Face



Not a face



Examples: Linear regression,
Logistic regression, Neural Network

Examples: Mean-squared error,
Cross Entropy

A Recipe for Machine Learning

1. Given training data:

$$\mathcal{D} = \{\mathbf{x}^{(i)}, y^{(i)}\}_{i=1}^N$$

2. Choose each of these:

– Decision function

$$\hat{y} = h_{\boldsymbol{\theta}}(\mathbf{x})$$

– Loss function

$$\ell(\hat{y}, y) \in \mathbb{R}$$

3. Define goal:

$$\hat{\boldsymbol{\theta}} \approx \underset{\boldsymbol{\theta}}{\operatorname{argmin}} \sum_{i=1}^N \ell(h_{\boldsymbol{\theta}}(\mathbf{x}^{(i)}), y^{(i)})$$

4. Train with SGD:

(take small steps
opposite the gradient)

$$\boldsymbol{\theta}^{(t+1)} = \boldsymbol{\theta}^{(t)} - \eta_t \nabla \ell(h_{\boldsymbol{\theta}}(\mathbf{x}^{(i)}), y^{(i)})$$

Background

1. Given training data:

$$\mathcal{D} = \{\mathbf{x}^{(i)}, y^{(i)}\}_{i=1}^N$$

2. Choose each of these:

- Decision function

$$\hat{y} = h_{\theta}(\mathbf{x})$$

- Loss function

$$\ell(\hat{y}, y) \in \mathbb{R}$$

Gradients

Backpropagation can compute this gradient!

And it's a **special case of a more general algorithm** called reverse-mode automatic differentiation that can compute the gradient of any differentiable function efficiently!

opposite the gradient)

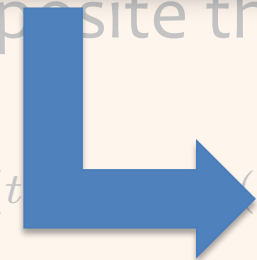
$$\theta^{(t)} \leftarrow \theta^{(t)} - \eta_t \nabla \ell(h_{\theta}(\mathbf{x}^{(i)}), y^{(i)})$$

Goal for Today's Lecture

1. Given training

$$\mathcal{D} = \{\mathbf{x}^{(i)}, y^{(i)}\}$$

Explore a **new class of decision functions**
(Neural Networks)

2. Choose each of these:

– Decision function

$$\hat{y} = h_{\theta}(\mathbf{x})$$

– Loss function

$$\ell(\hat{y}, y) \in \mathbb{R}$$

4. Train with SGD:

(take small steps opposite the gradient)

$$\theta^{(t+1)} = \theta^{(t)} - \eta_t \nabla \ell(h_{\theta}(\mathbf{x}^{(i)}), y^{(i)})$$



$$y = h_{\theta}(\mathbf{x}) = \sigma(\boldsymbol{\theta}^T \mathbf{x})$$

where $\sigma(a) = a$

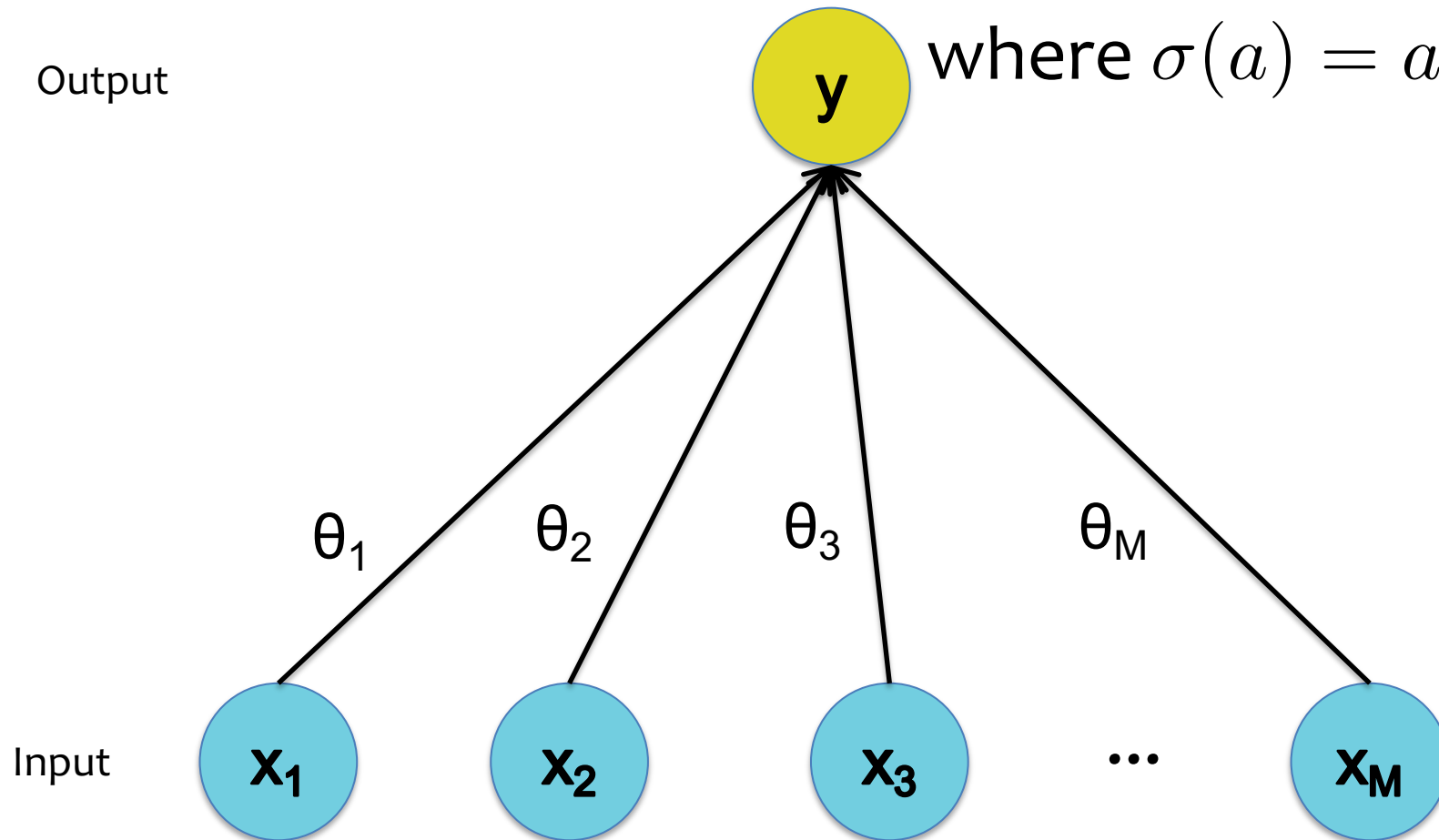

$$y = h_{\theta}(\mathbf{x}) = \sigma(\theta^T \mathbf{x})$$

where $\sigma(a) = \frac{1}{1 + \exp(-a)}$

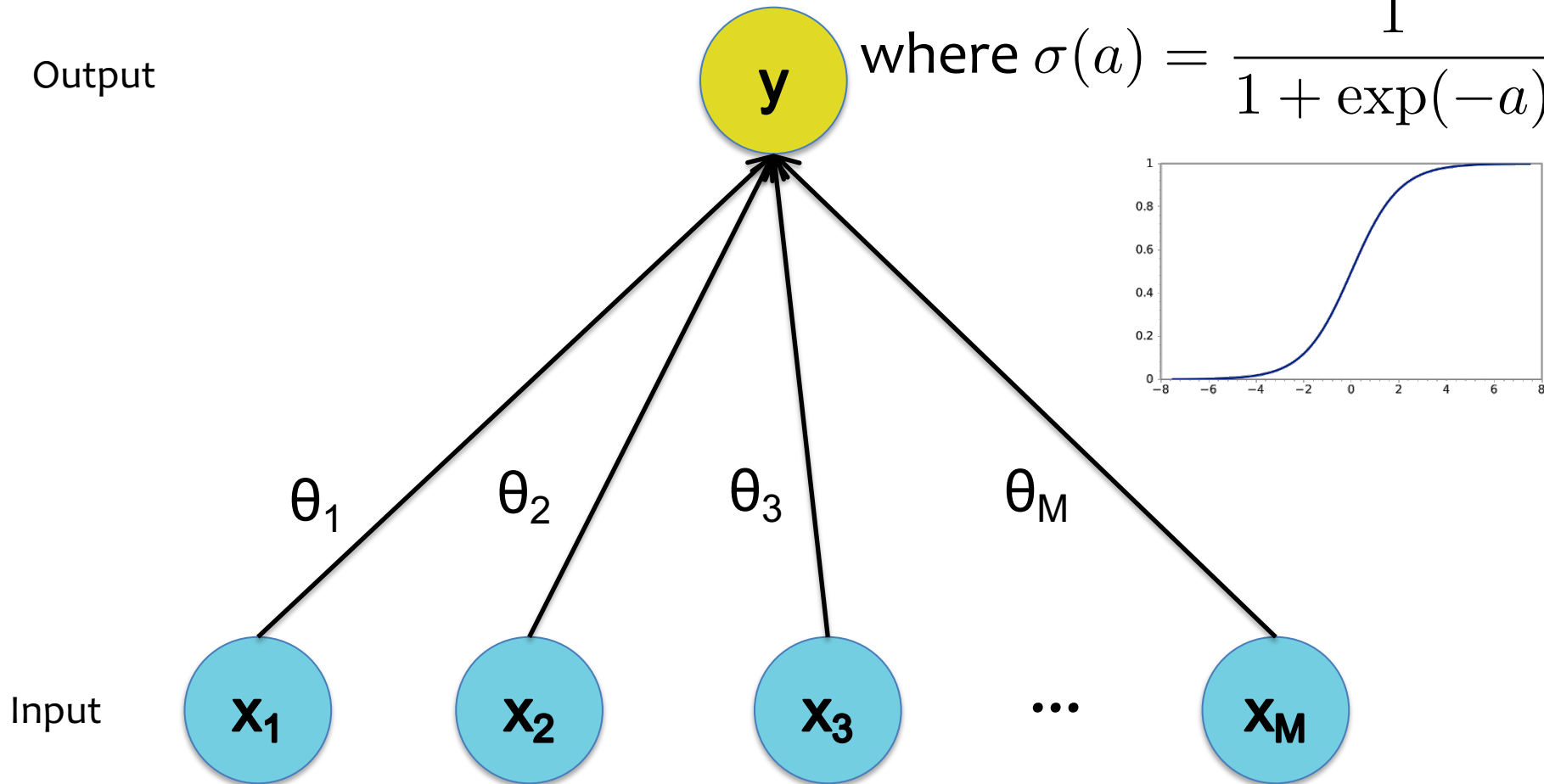

$$y = h_{\theta}(\mathbf{x}) = \sigma(\theta^T \mathbf{x})$$

where $\sigma(a) = \text{sign}(a)$

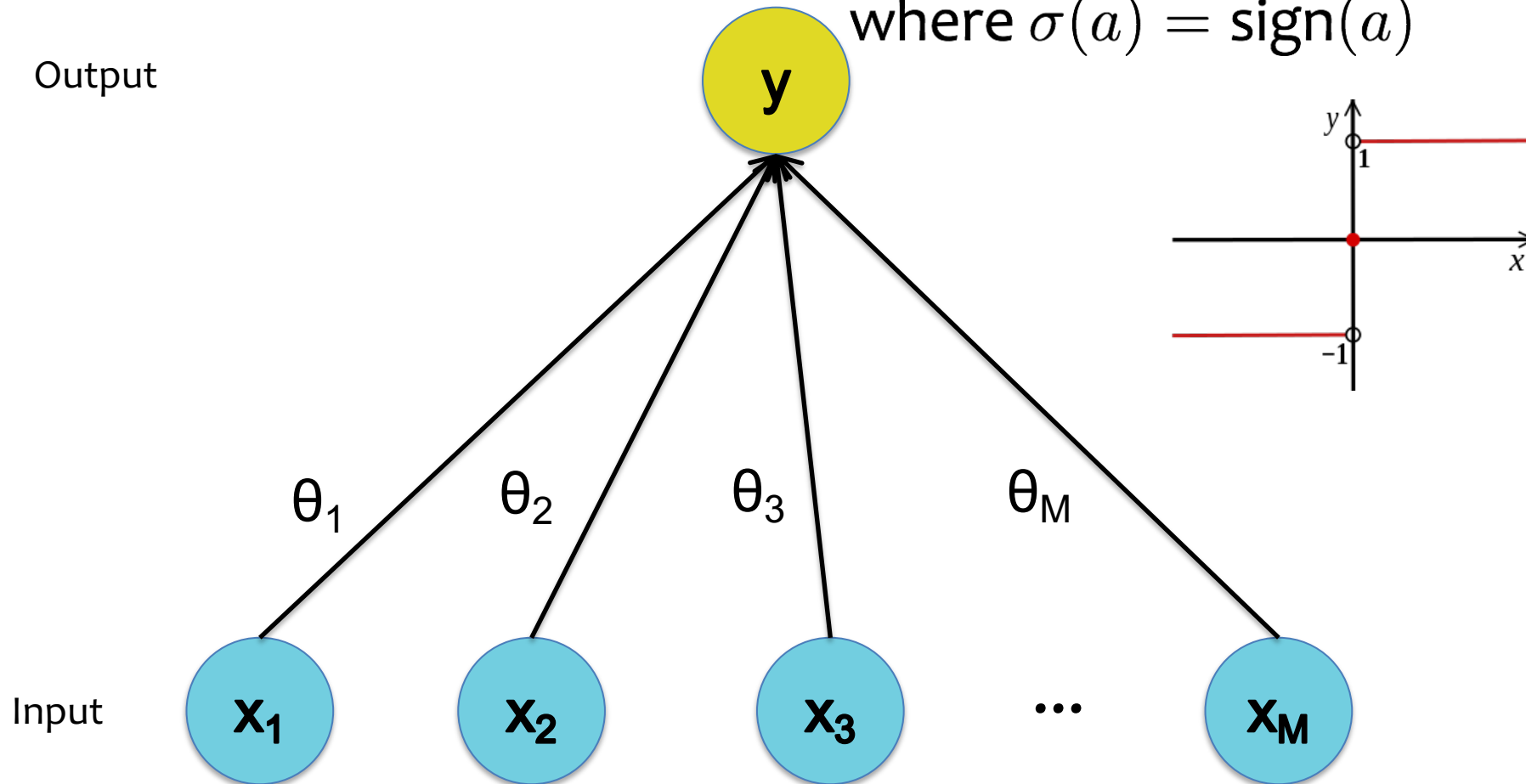

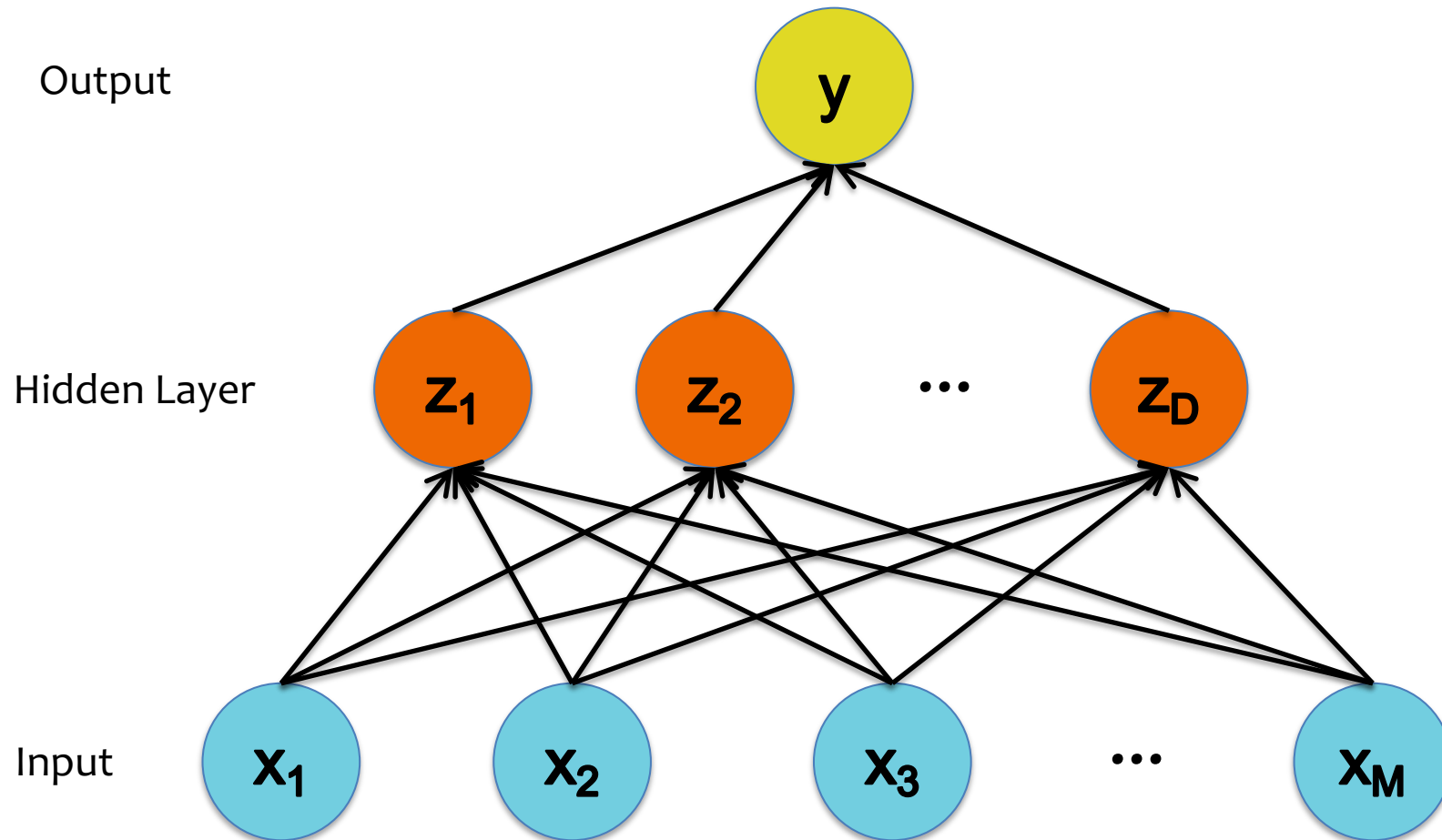

COMPONENTS OF A NEURAL NETWORK

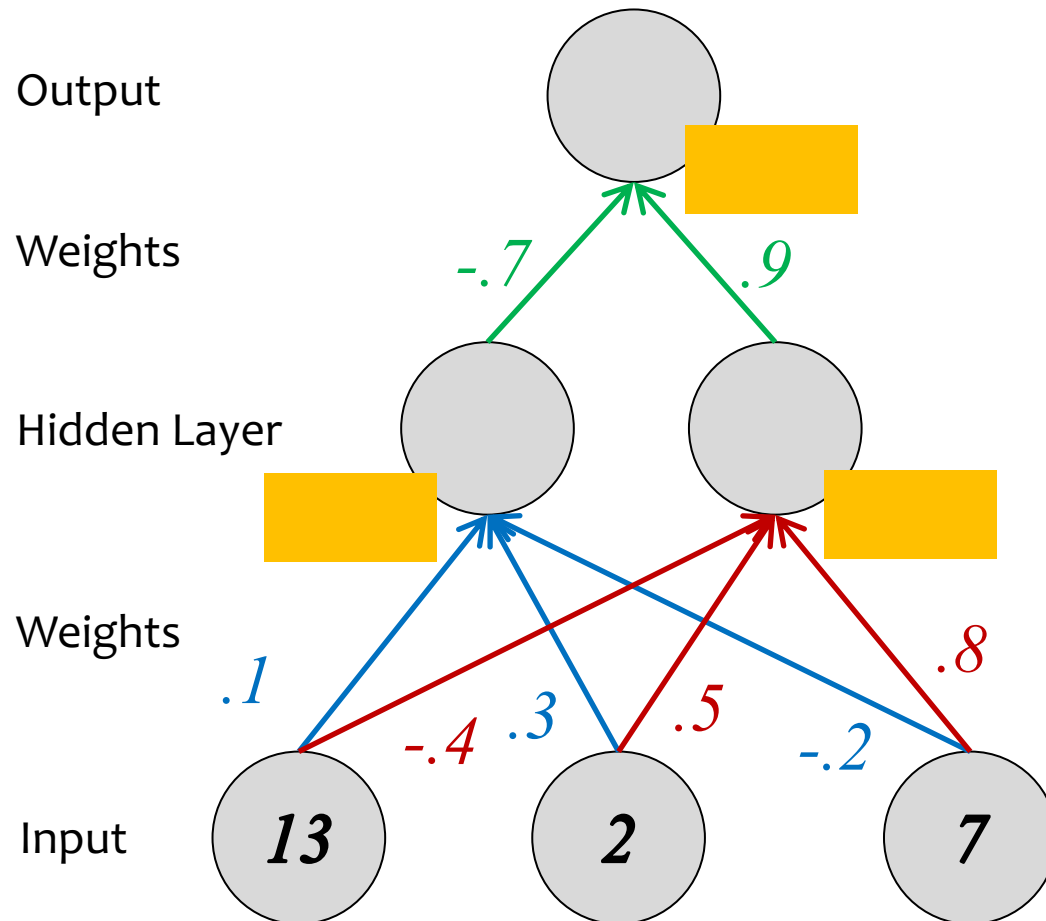

Suppose we already learned the weights of the neural network.

To make a new prediction, we take in some new features (aka. the input layer) and perform the feed-forward computation.

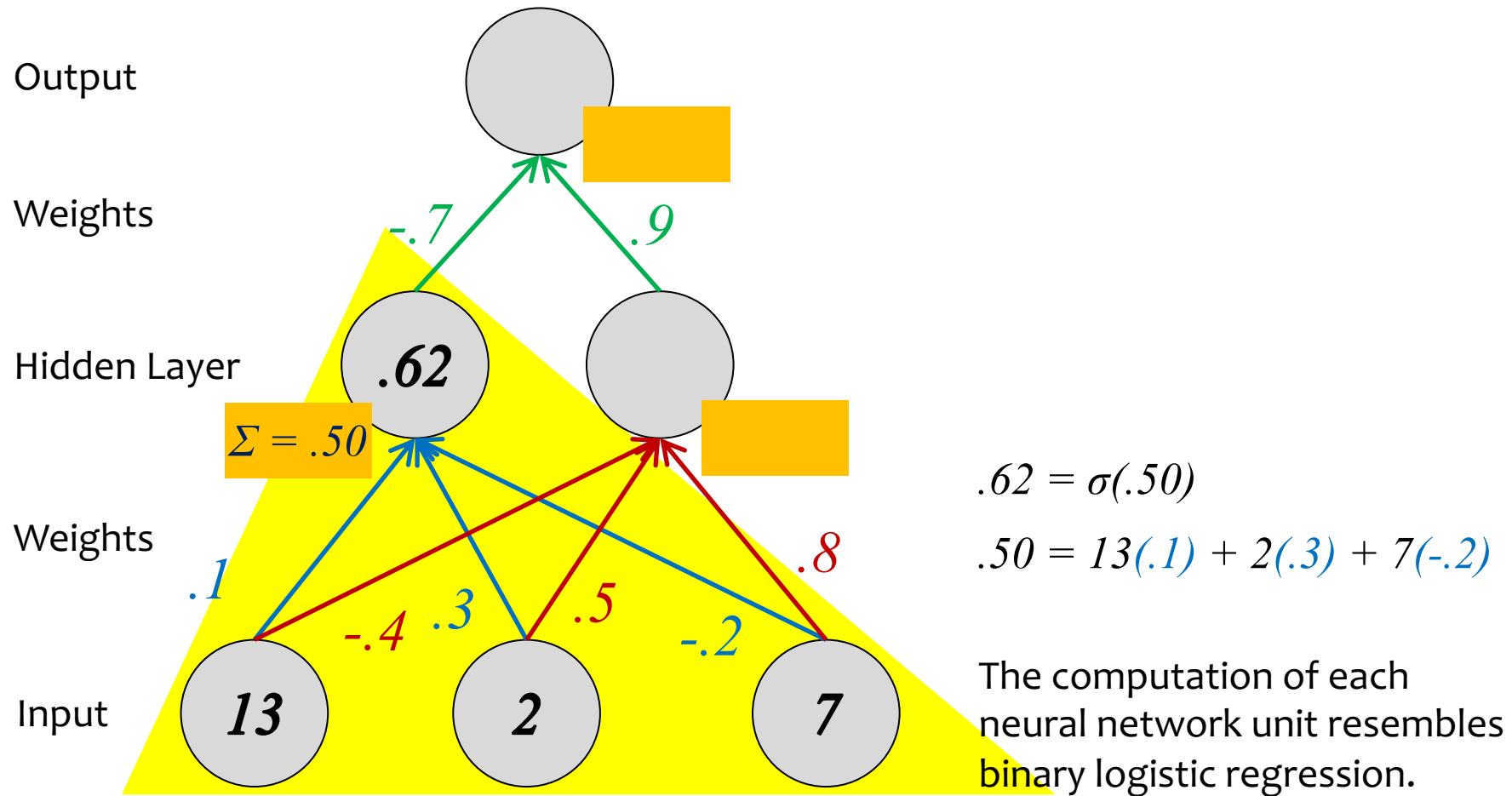

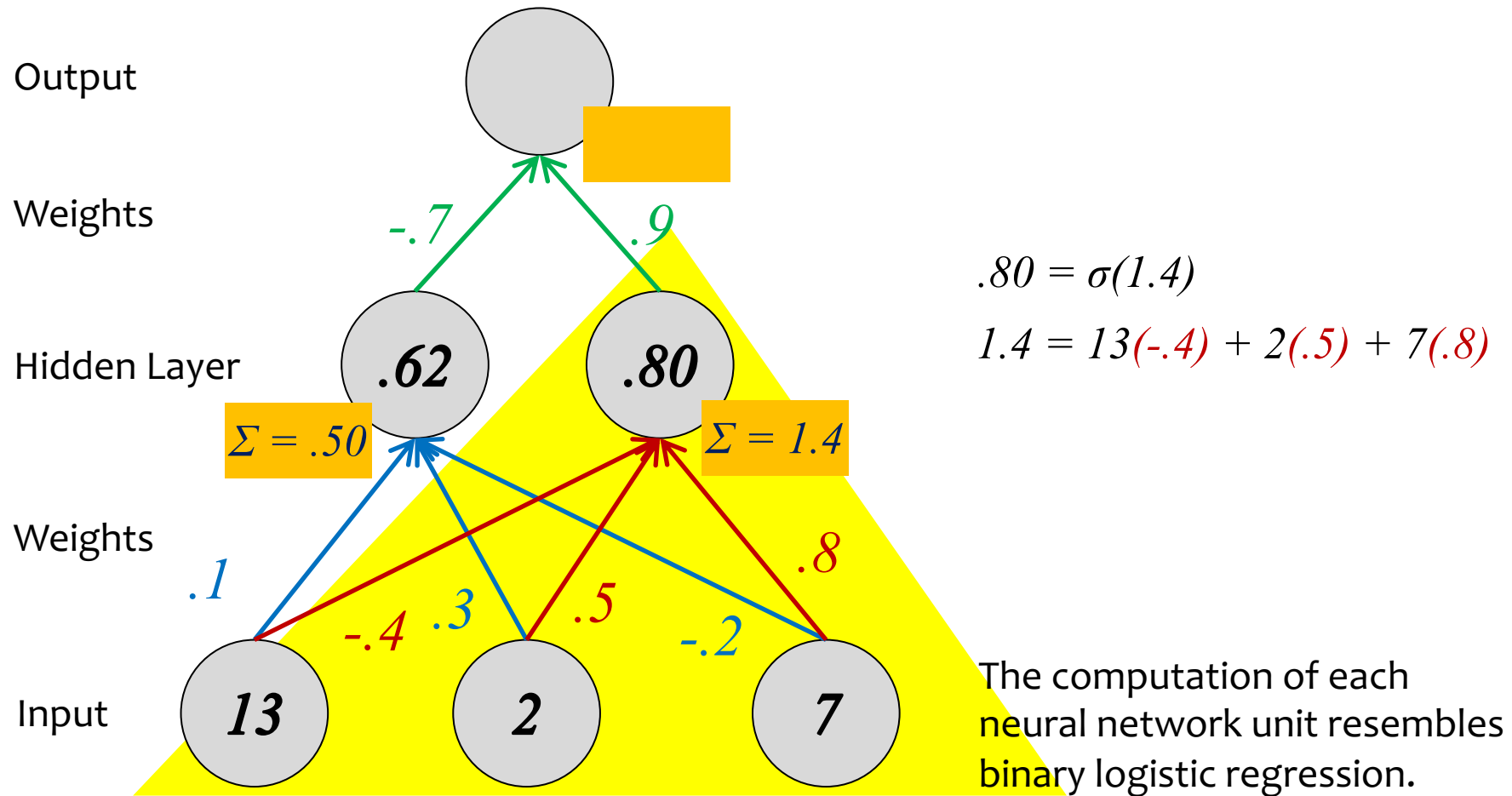

Decision Functions

Neural Network

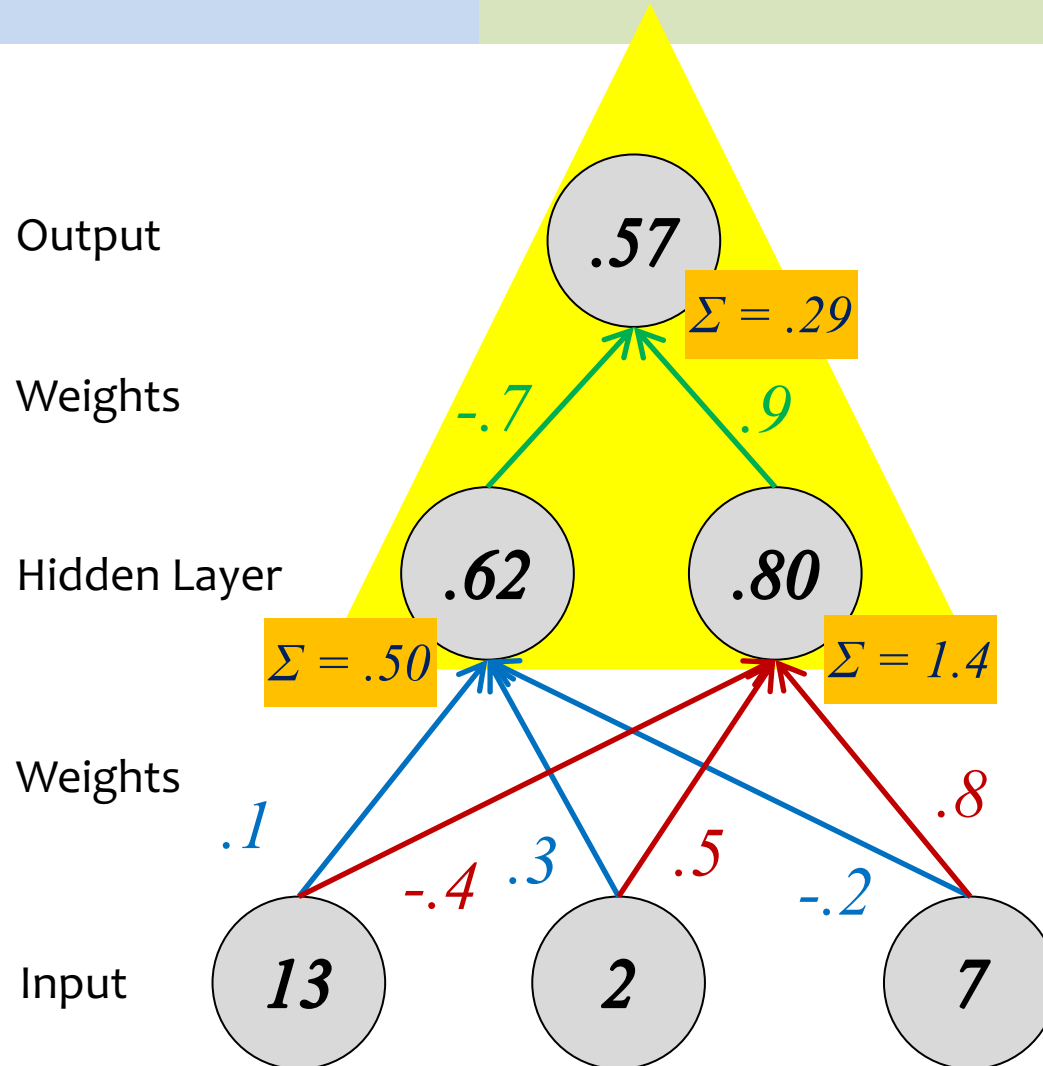

$$.57 = \sigma(.29)$$

$$.29 = .62(-.7) + .80(.9)$$

The computation of each neural network unit resembles binary logistic regression.

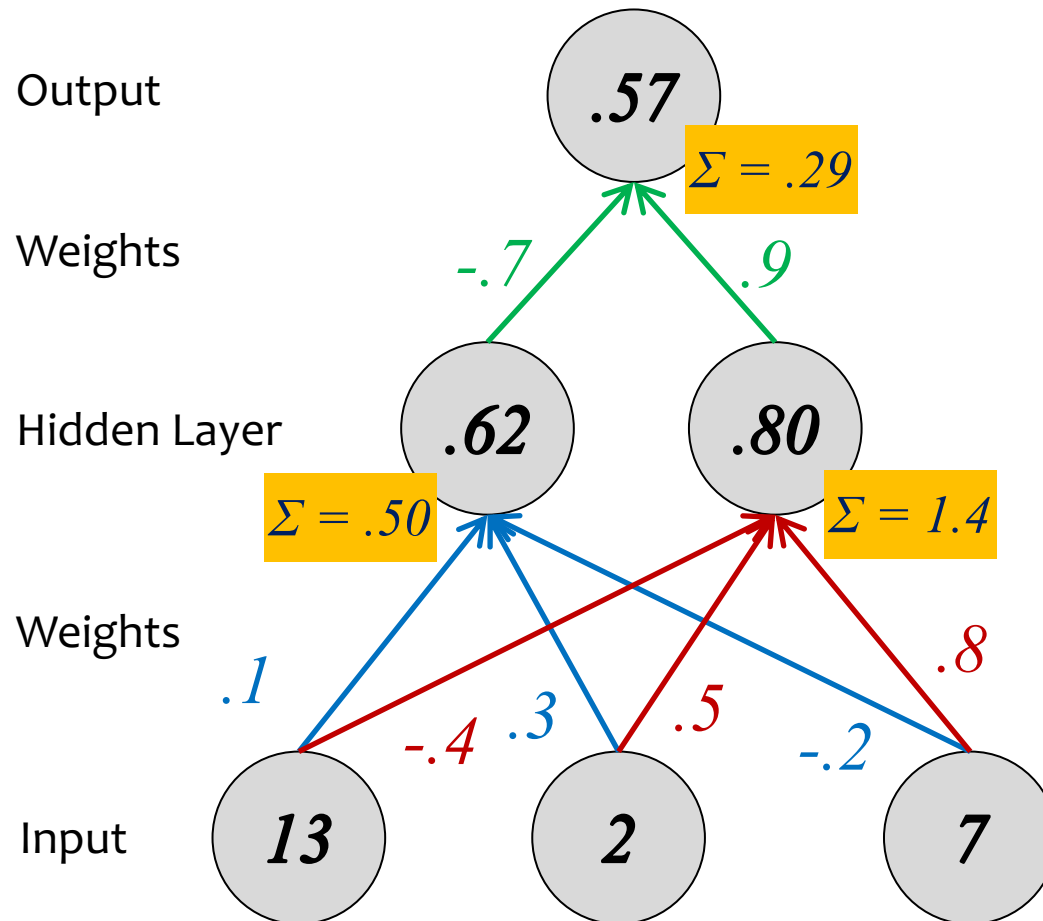

$$.57 = \sigma(.29)$$

$$.29 = .62(-.7) + .80(.9)$$

$$.80 = \sigma(1.4)$$

$$1.4 = 13(-.4) + 2(.5) + 7(.8)$$

$$.62 = \sigma(.50)$$

$$.50 = 13(.1) + 2(.3) + 7(-.2)$$

The computation of each neural network unit resembles binary logistic regression.

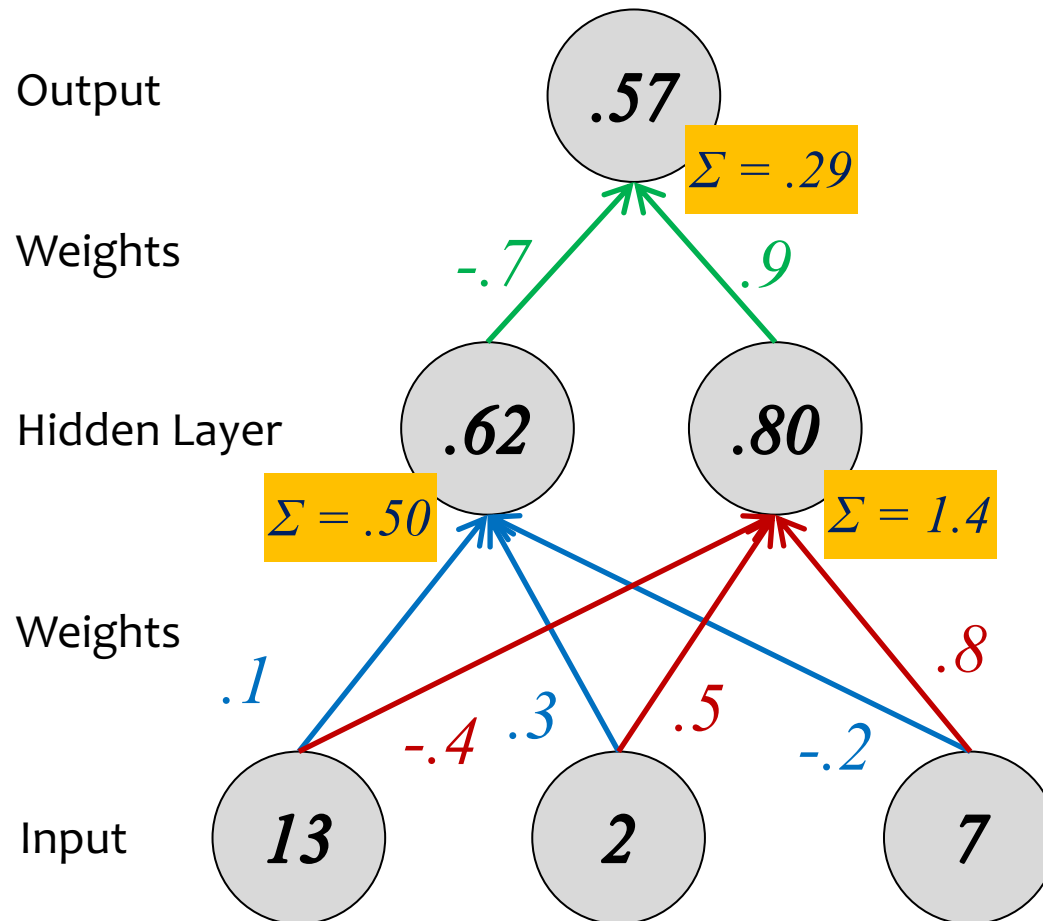

Except we only have the target value for y at training time!

We have to learn to create “useful” values of z_1 and z_2 in the hidden layer.



The computation of each neural network unit resembles binary logistic regression.

From Biological to Artificial

The motivation for Artificial Neural Networks comes from biology...

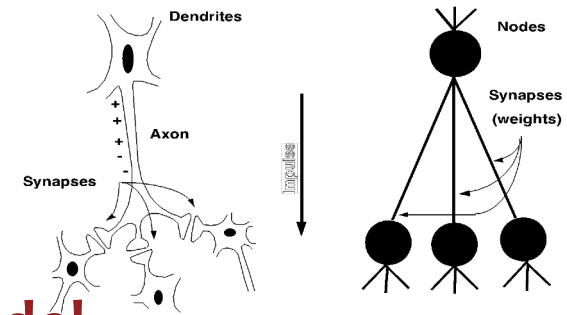

Biological “Model”

- **Neuron:** an excitable cell
- **Synapse:** connection between neurons
- A neuron sends an **electrochemical pulse** along its *synapses* when a sufficient voltage change occurs
- **Biological Neural Network:** collection of neurons along some pathway through the brain

Biological “Computation”

- Neuron switching time : ~ 0.001 sec
- Number of neurons: $\sim 10^{10}$
- Connections per neuron: $\sim 10^{4-5}$
- Scene recognition time: ~ 0.1 sec

Artificial Model

- **Neuron:** node in a directed acyclic graph (DAG)
- **Weight:** multiplier on each edge
- **Activation Function:** nonlinear thresholding function, which allows a neuron to “fire” when the input value is sufficiently high
- **Artificial Neural Network:** collection of neurons into a DAG, which define some differentiable function

Artificial Computation

- Many neuron-like threshold switching units
- Many weighted interconnections among units
- Highly parallel, distributed processes

DEFINING A 1-HIDDEN LAYER NEURAL NETWORK

Example: Neural Network with One Hidden Layer

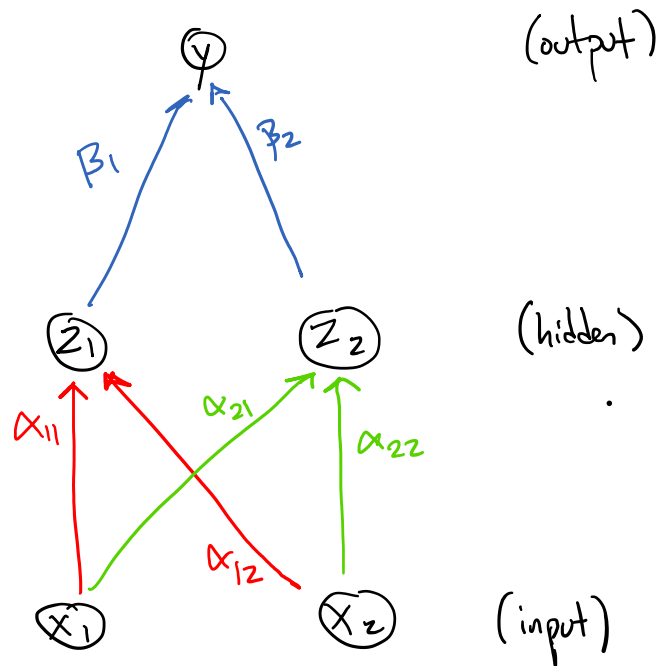

$x_i \in \mathbb{R}$
 $z_i \in (0,1)$ if σ is sigmoid
 $z_i \in \mathbb{R}$ more generally

Let σ be the activation function
 Assume $\sigma(a) = \frac{1}{1 + \exp(-a)}$ is sigmoid

$$z_1 = \sigma(\alpha_{11}x_1 + \alpha_{12}x_2 + \alpha_{10})$$

$$z_2 = \sigma(\alpha_{21}x_1 + \alpha_{22}x_2 + \alpha_{20})$$

$$\begin{aligned}
 y &= \sigma(\beta_1 z_1 + \beta_2 z_2 + \beta_0) \\
 &= \sigma(\beta_1 \sigma(\alpha_{11}x_1 + \alpha_{12}x_2 + \alpha_{10}) \\
 &\quad + \beta_2 \sigma(\alpha_{21}x_1 + \alpha_{22}x_2 + \alpha_{20}) \\
 &\quad + \beta_0)
 \end{aligned}$$

Don't forget the intercept terms

$$\rightarrow = \Pr(Y=1 | \vec{x}, \alpha, \beta)$$

Classify using the Bayes Optimal Classifier

$$\hat{y} = h_{\alpha, \beta}(\vec{x}) = \begin{cases} 1 & \text{if } y \geq 0.5 \\ 0 & \text{otherwise} \end{cases}$$

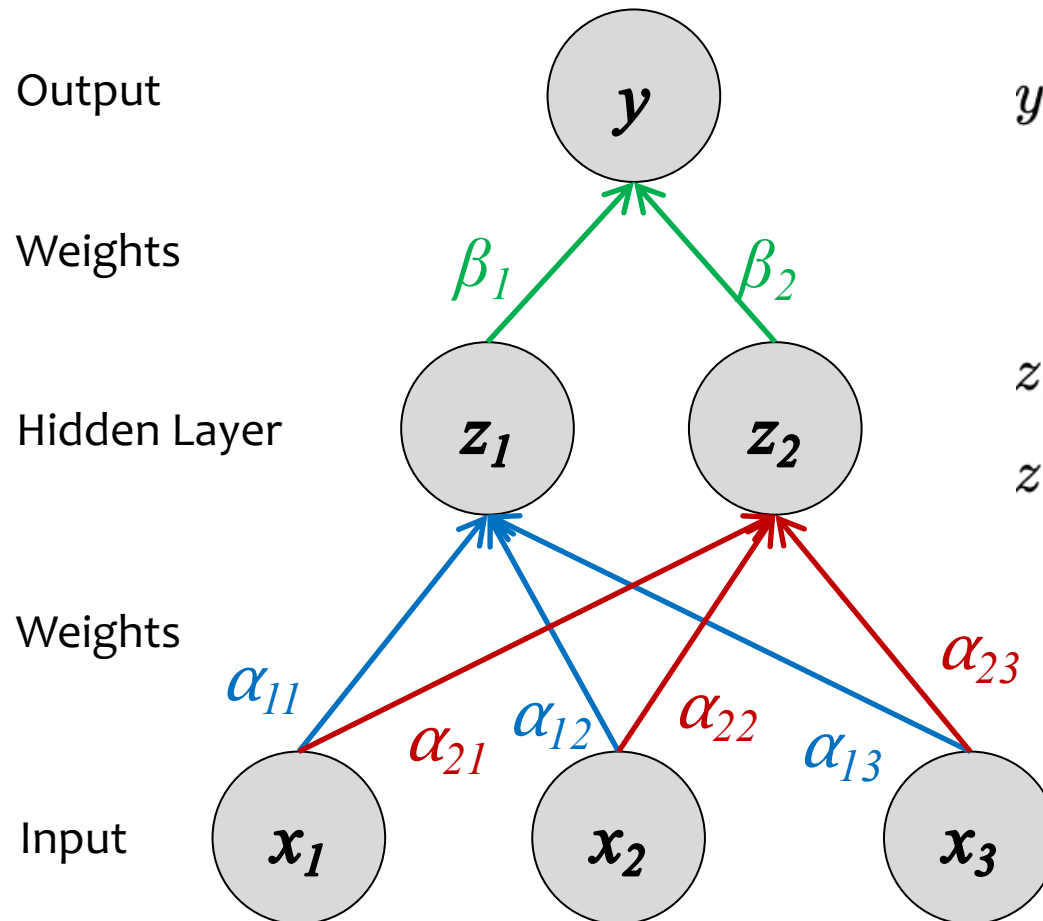

$$y = \sigma(\beta_1 z_1 + \beta_2 z_2)$$

$$z_2 = \sigma(\alpha_{21} x_1 + \alpha_{22} x_2 + \alpha_{23} x_3)$$

$$z_1 = \sigma(\alpha_{11} x_1 + \alpha_{12} x_2 + \alpha_{13} x_3)$$

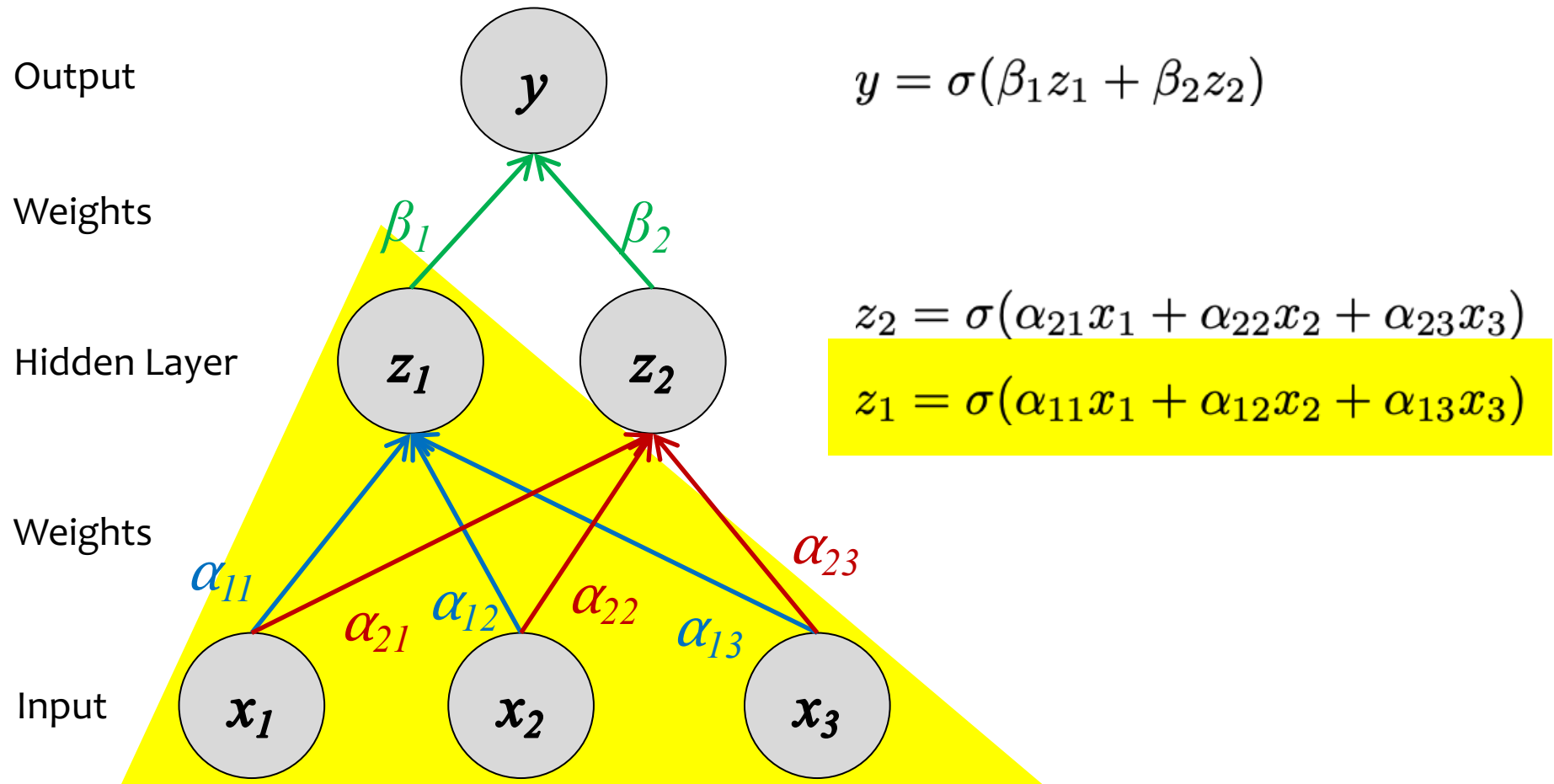

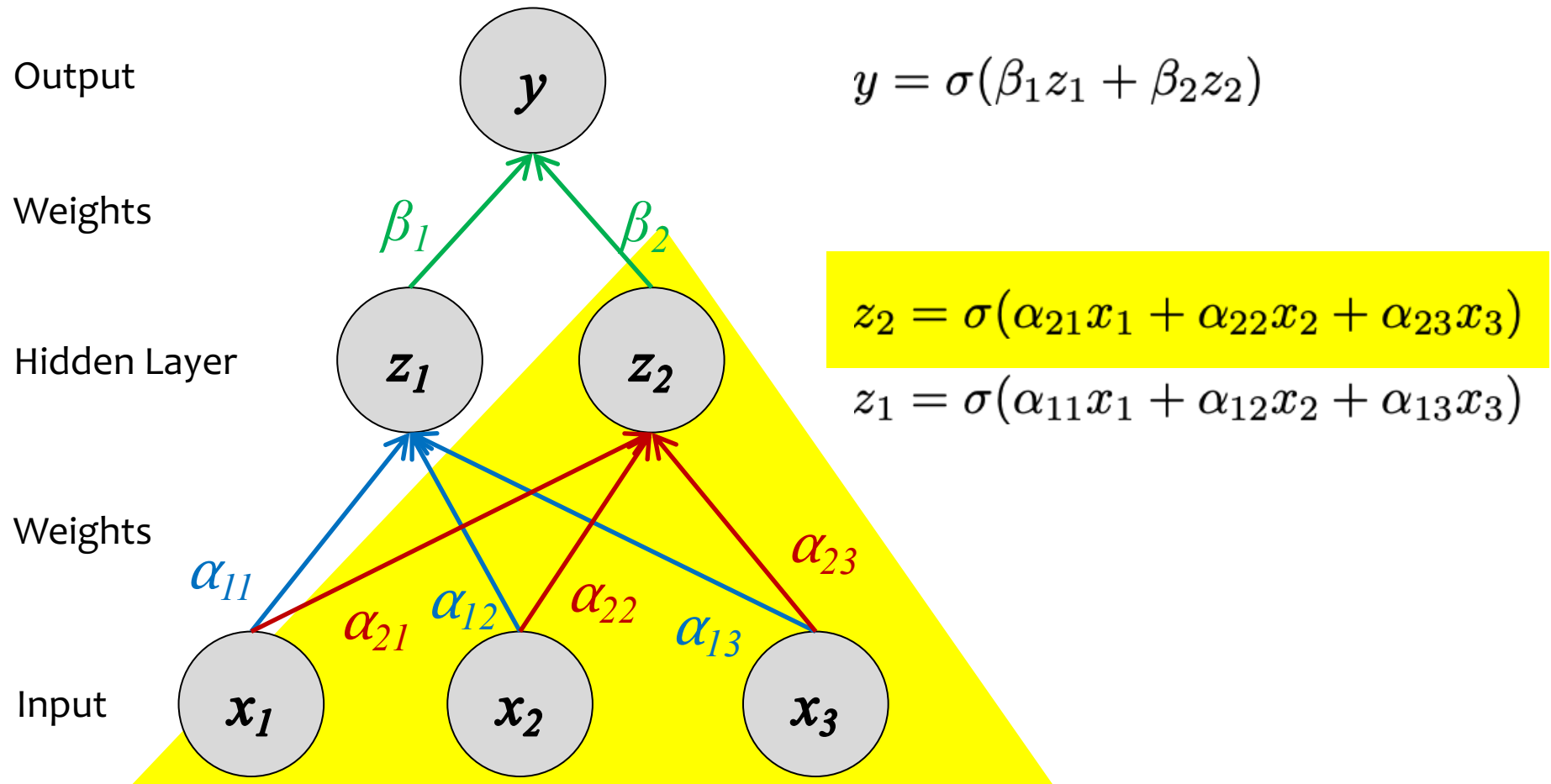

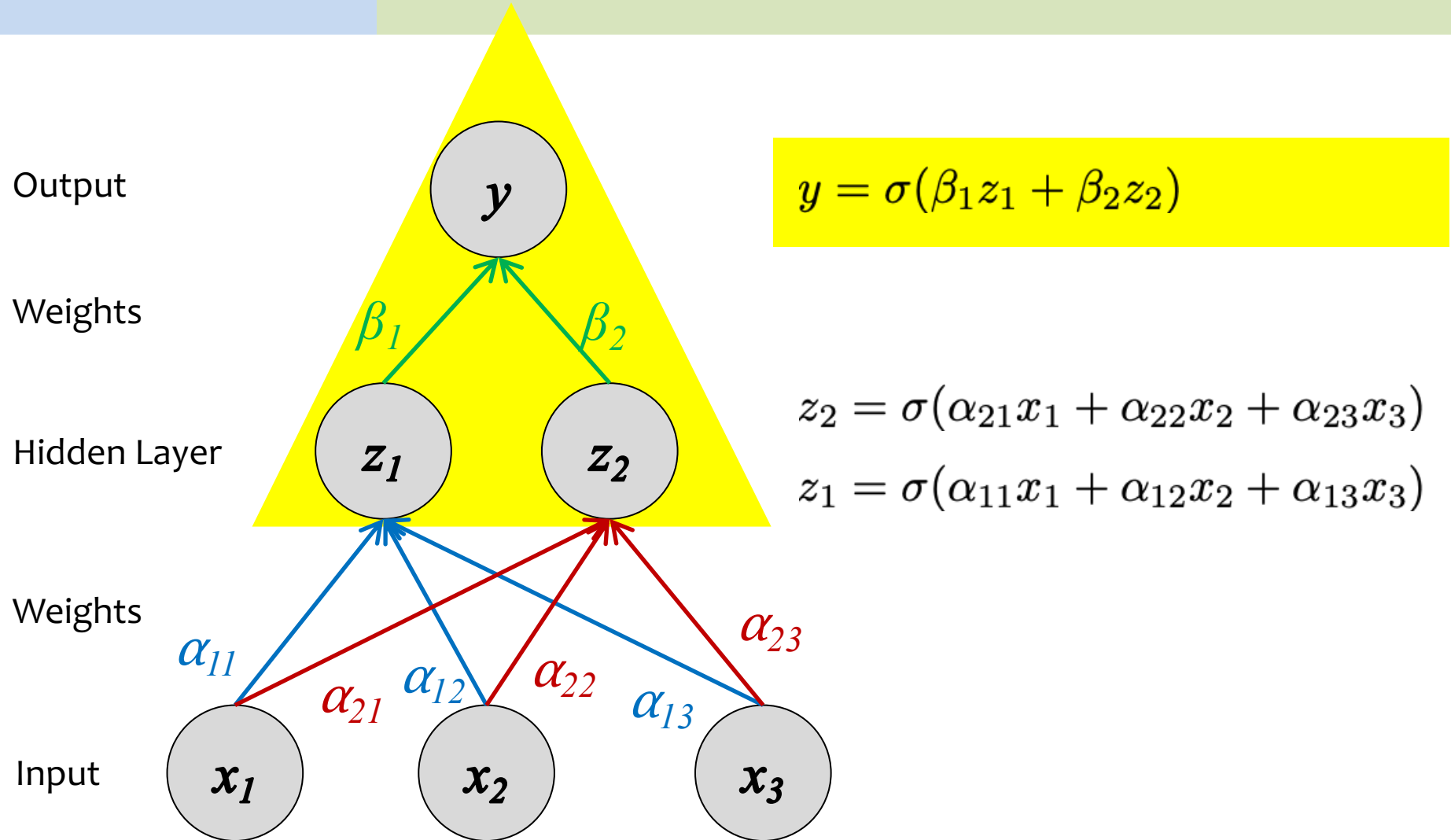

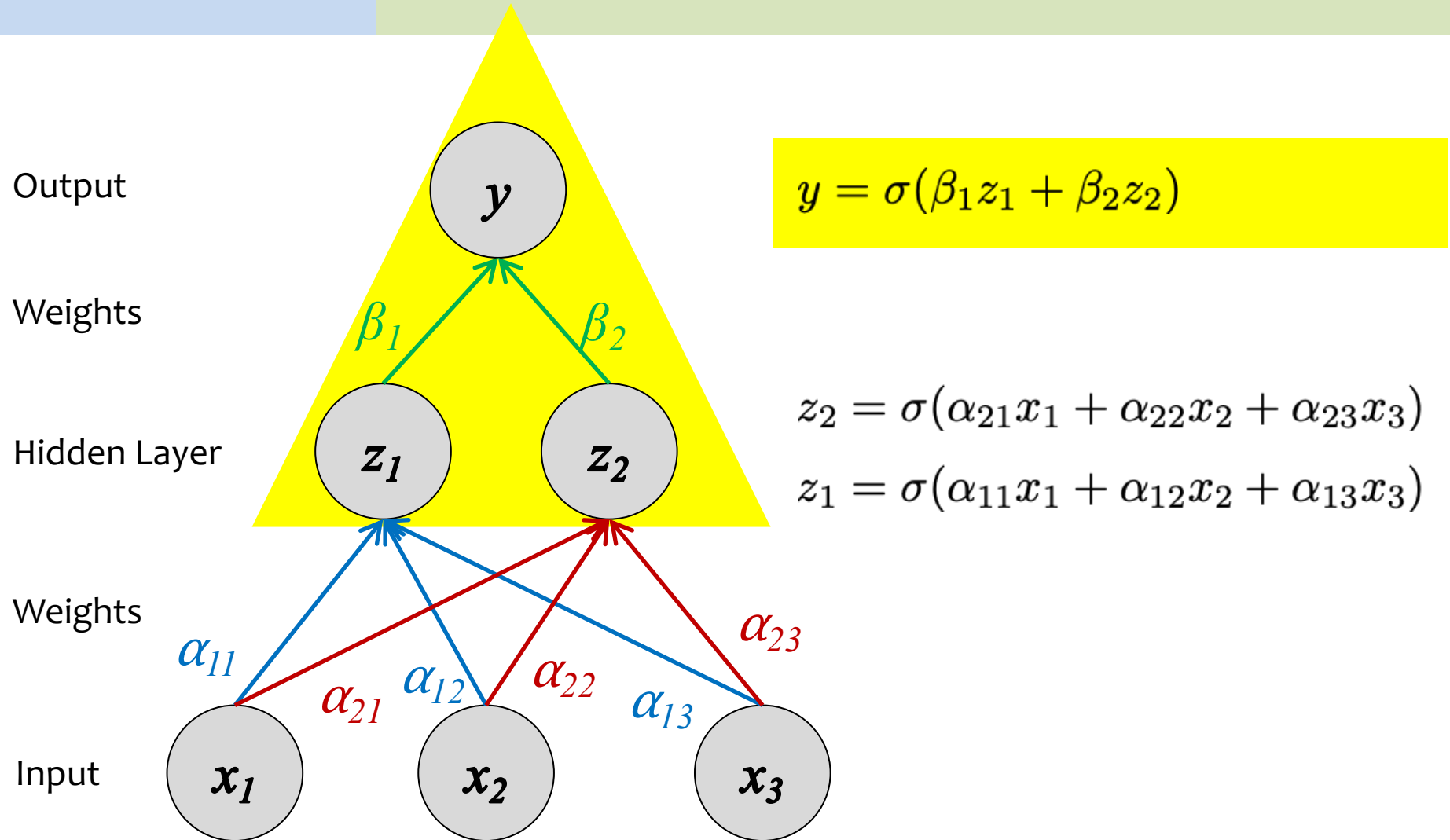

NONLINEAR DECISION BOUNDARIES AND NEURAL NETWORKS

Example: Face Recognition

Face Recognition Data

Face



Face



Not a face

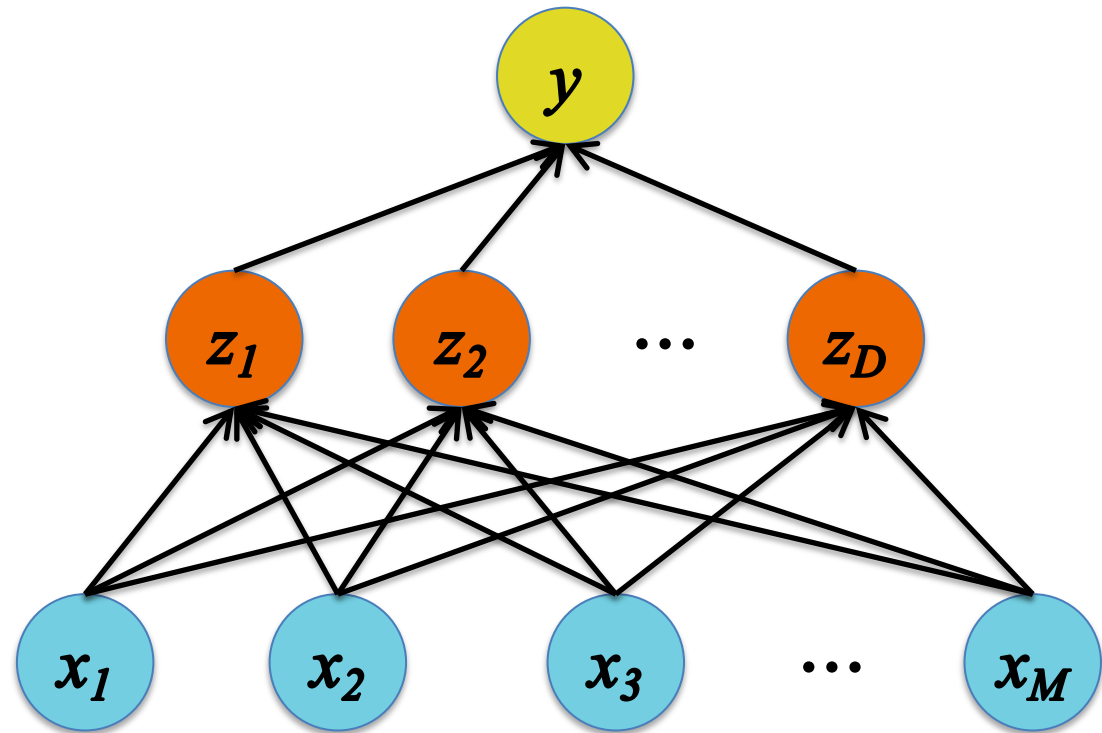

Example: Face Recognition

Face Recognition Data

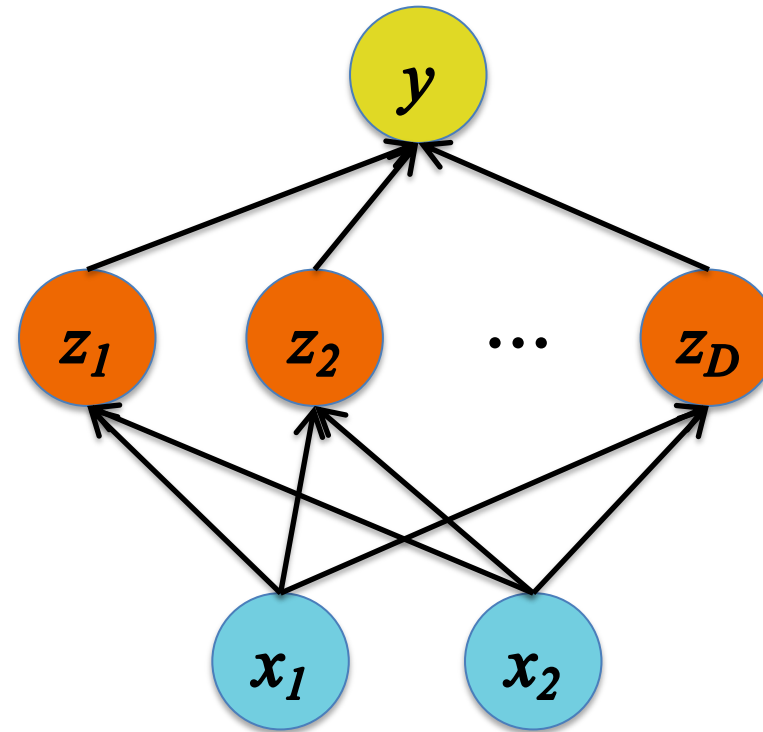
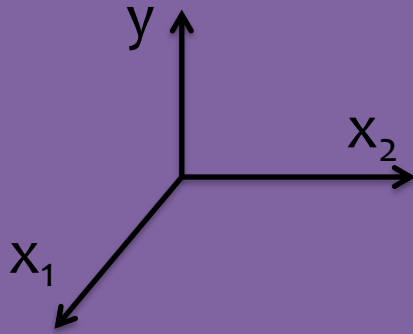
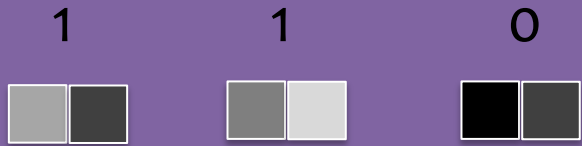

Example: Face Recognition

Face Recognition Data

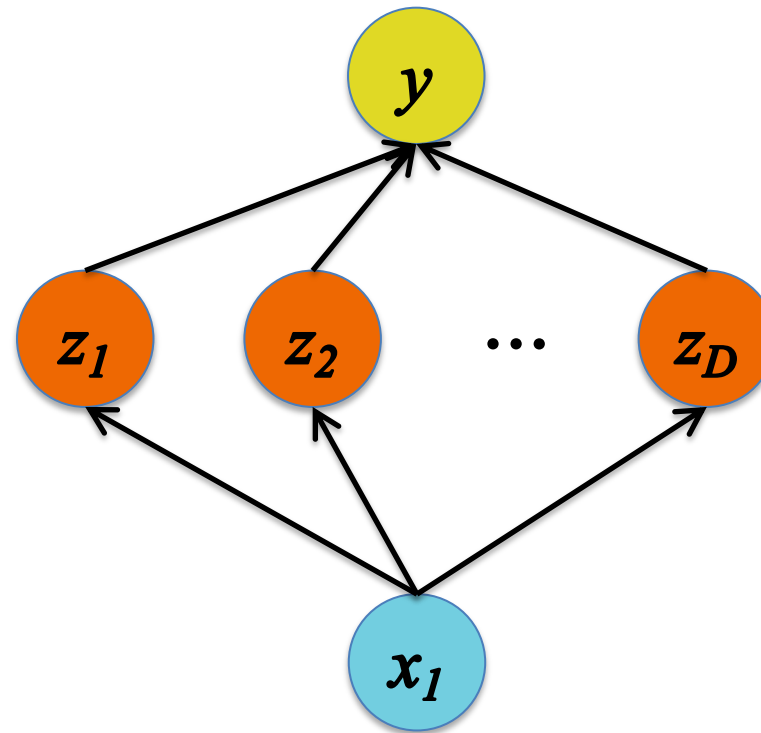
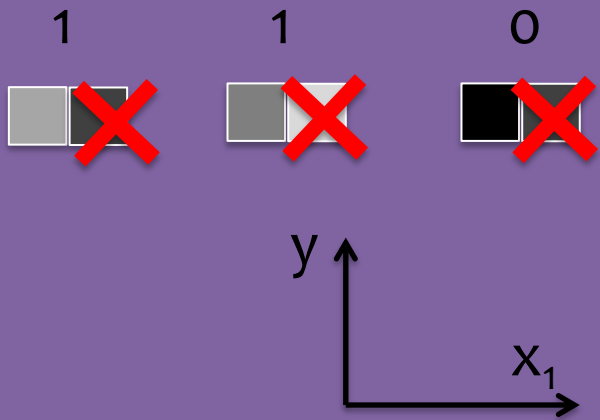

1D Face Recognition

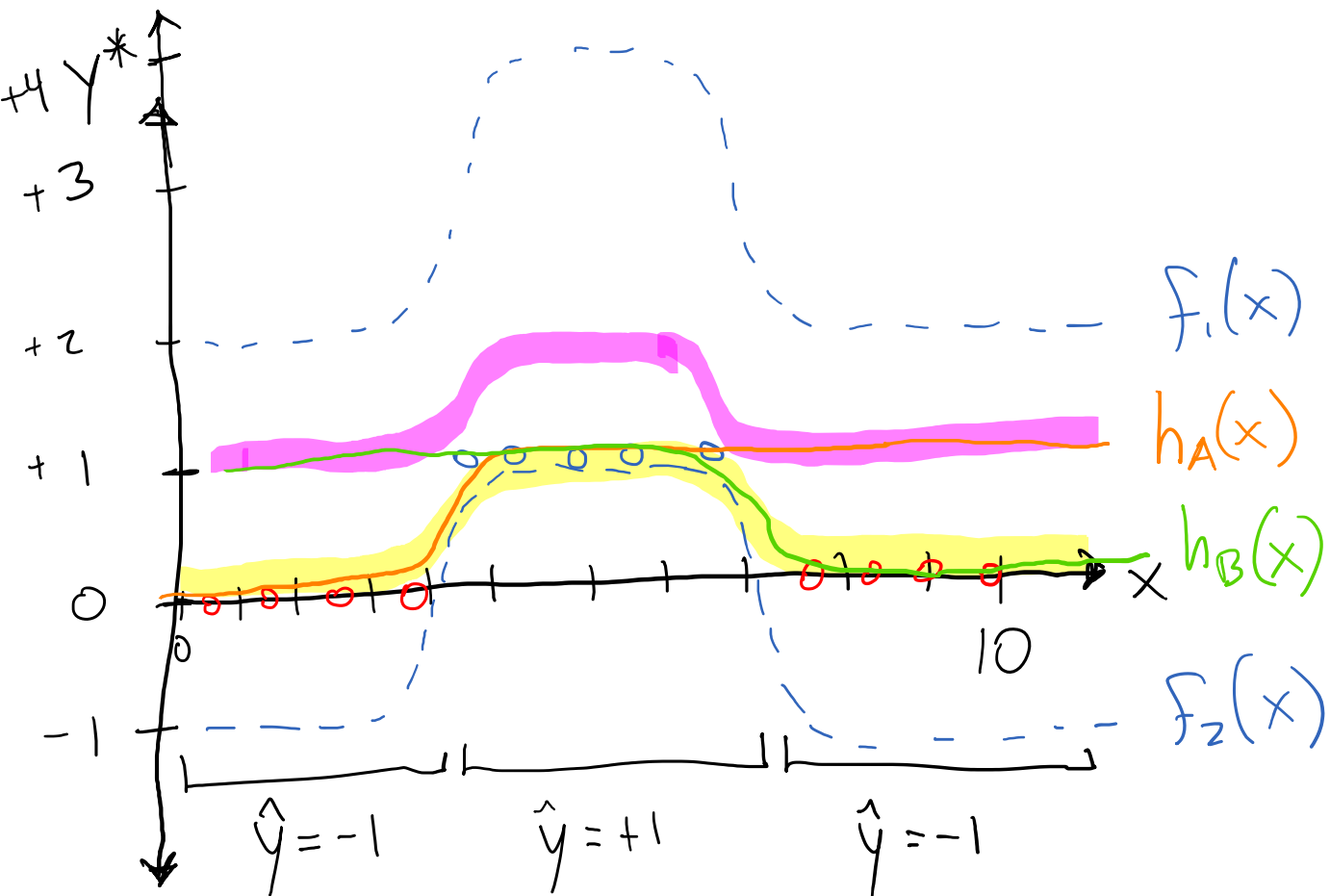
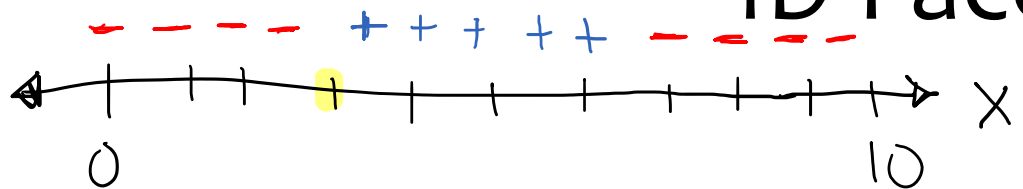

Q: What is $z_c(x) = h_A(x) + h_B(x)$?

Q: What is this function?

$$h_c(x) = \sigma(w_1 h_A(x) + w_2 h_B(x) + w_3)$$

where $w_1 = 2$ and $w_2 = 2$ and $w_3 = -3$

$f_1(x)$ $f_2(x)$

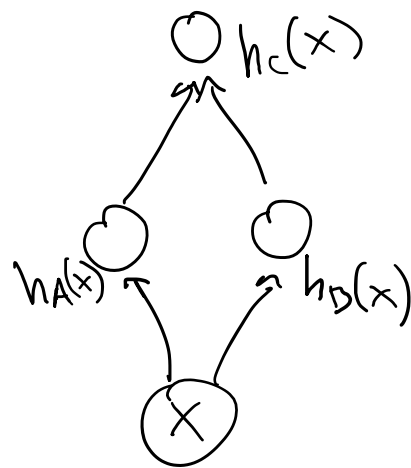

Example: Face Recognition

Face Recognition Data

Face



Face



Not a face

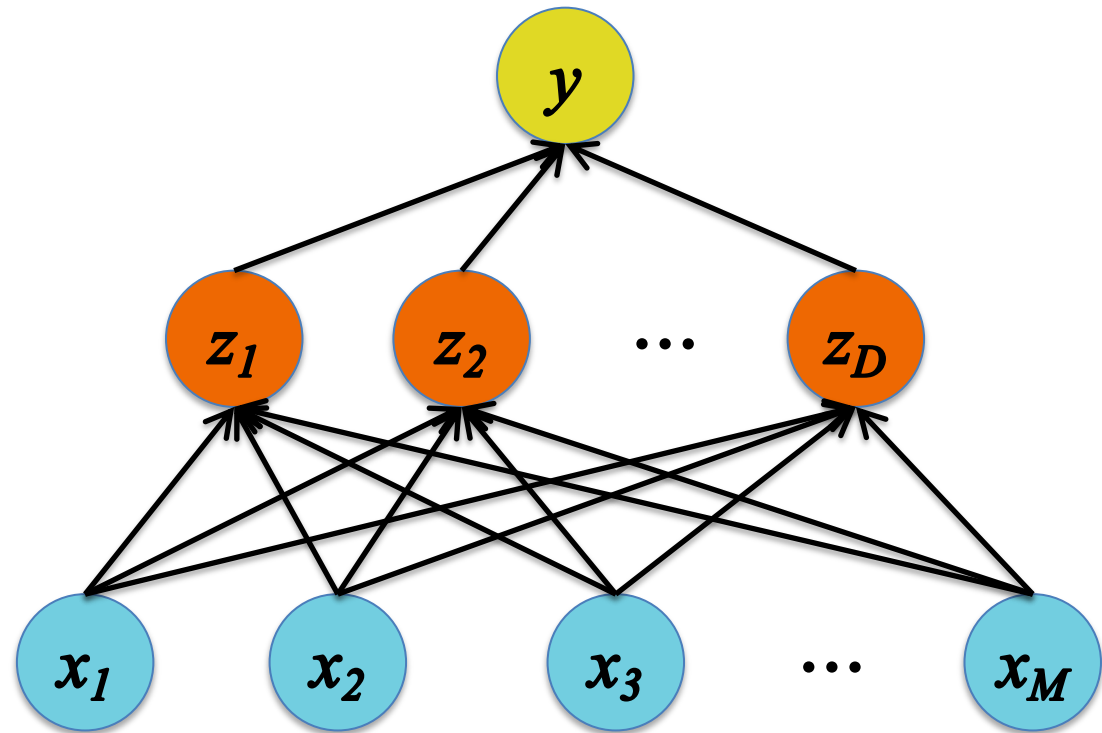

Example: Face Recognition

Face Recognition Data

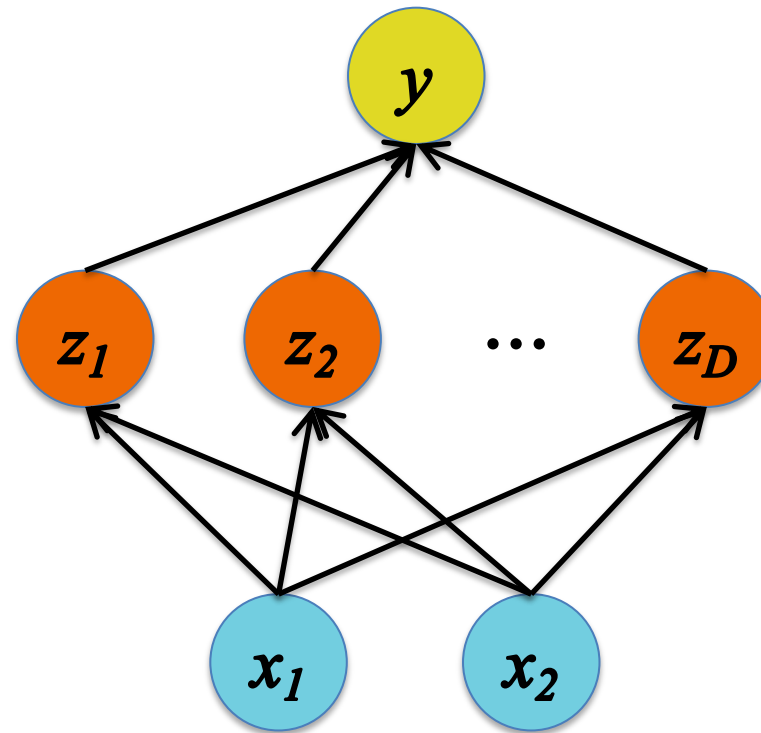
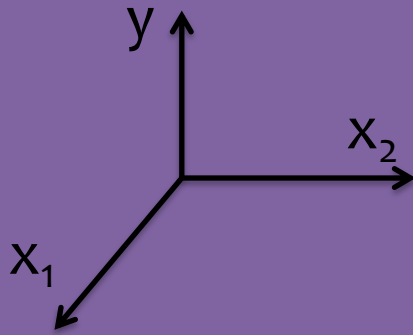
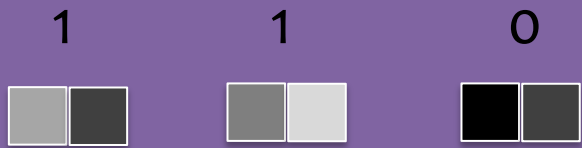

Example: Face Recognition

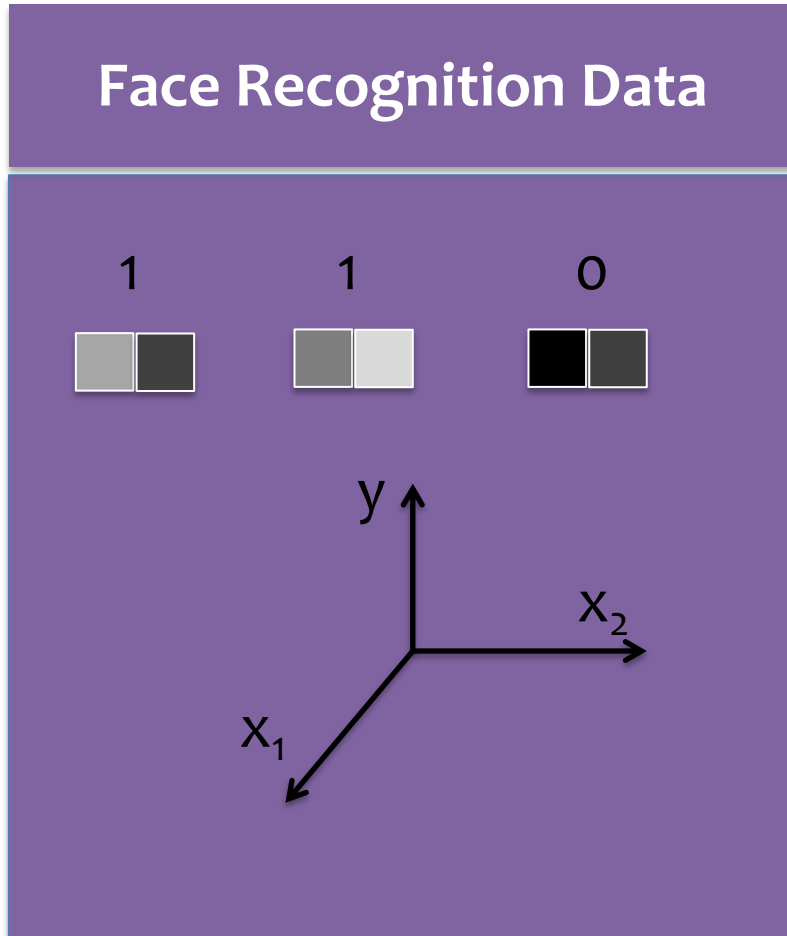

- x_1 and x_2 axes are on the floor, y axis is vertical
- each red point has $y=0$, and each blue point has $y=1$
- four training settings:
 - 1) train logistic regression on leftmost red points and all blue points
 - 2) train logistic regression on rightmost red points and all blue points
 - 3) train a neural network with $D=2$ hidden units on all points
 - 4) train a neural network with $D=4$ hidden units on all points
- each poster represents a hidden unit (as a function of $[x_1, x_2]$)
- decision boundary is line/curve on the floor

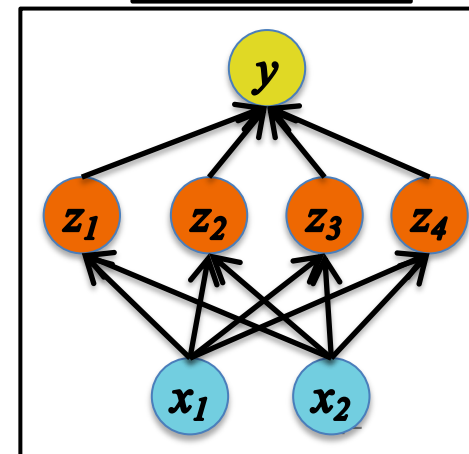
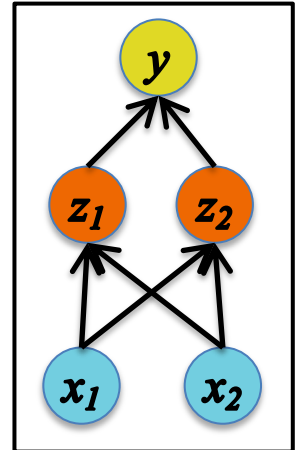
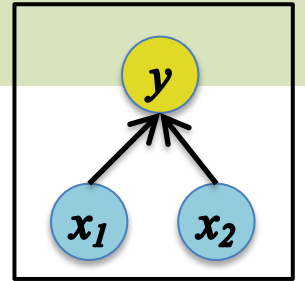

Neural Network Parameters

Poll Question 1:

Suppose you are training a one-hidden layer neural network with sigmoid activations for binary classification.



True or False: There is a unique set of parameters that maximize the likelihood of the dataset above.

A = toxic

B = True 35%

C = False 65%

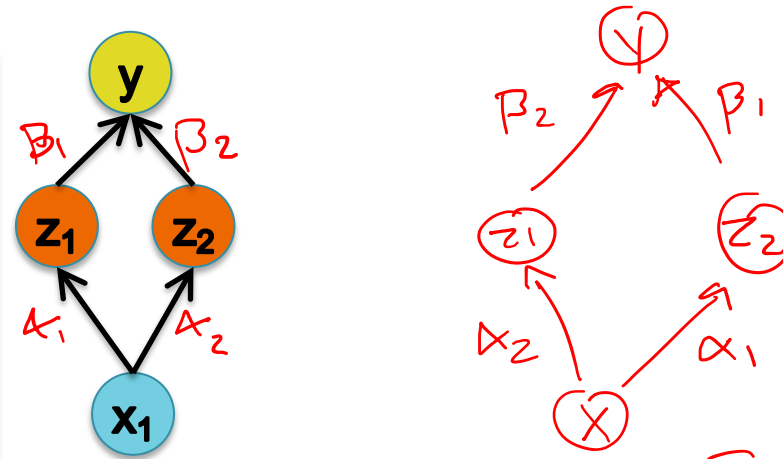

Answer:

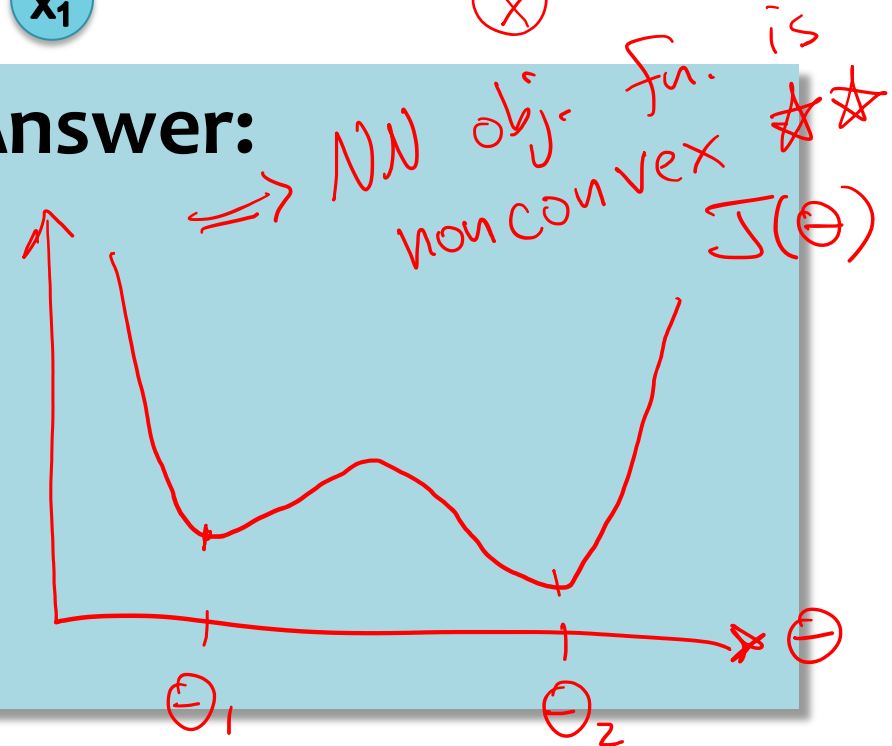

Neural Network Architectures

Even for a basic Neural Network, there are many design decisions to make:

1. # of hidden layers (depth)
2. # of units per hidden layer (width)
3. Type of activation function (nonlinearity)
4. Form of objective function
5. How to initialize the parameters

BUILDING WIDER NETWORKS

$$D = M$$

Building a Neural Net

Q: How many hidden units, D , should we use?

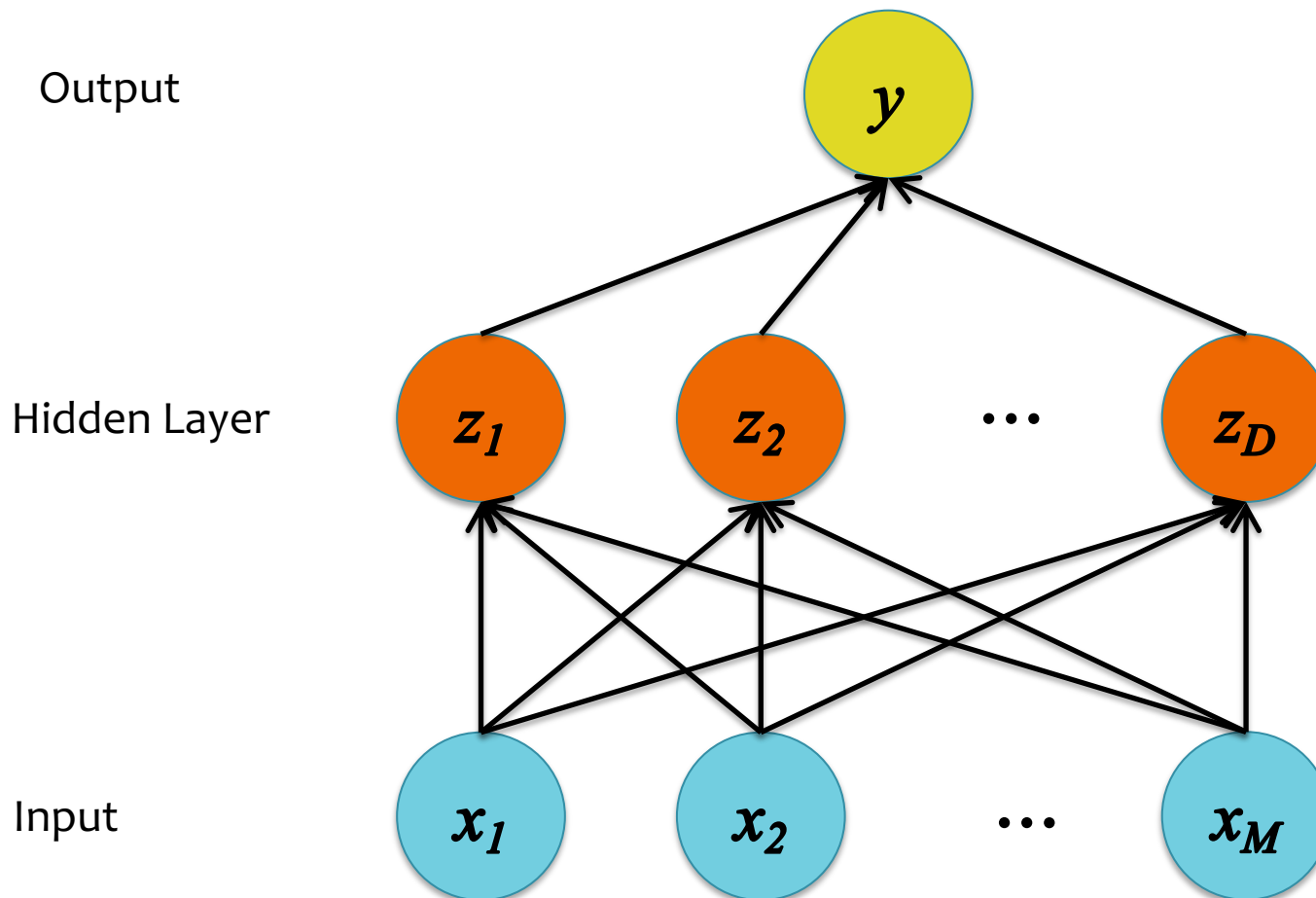

The hidden units could learn to be...

- ✓ a selection of the most useful features
- ✓ nonlinear combinations of the features
- a lower dimensional projection of the features
- a higher dimensional projection of the features
- ✓ a copy of the input features
- a mix of the above

$$D < M$$

Building a Neural Net

Q: How many hidden units, D , should we use?

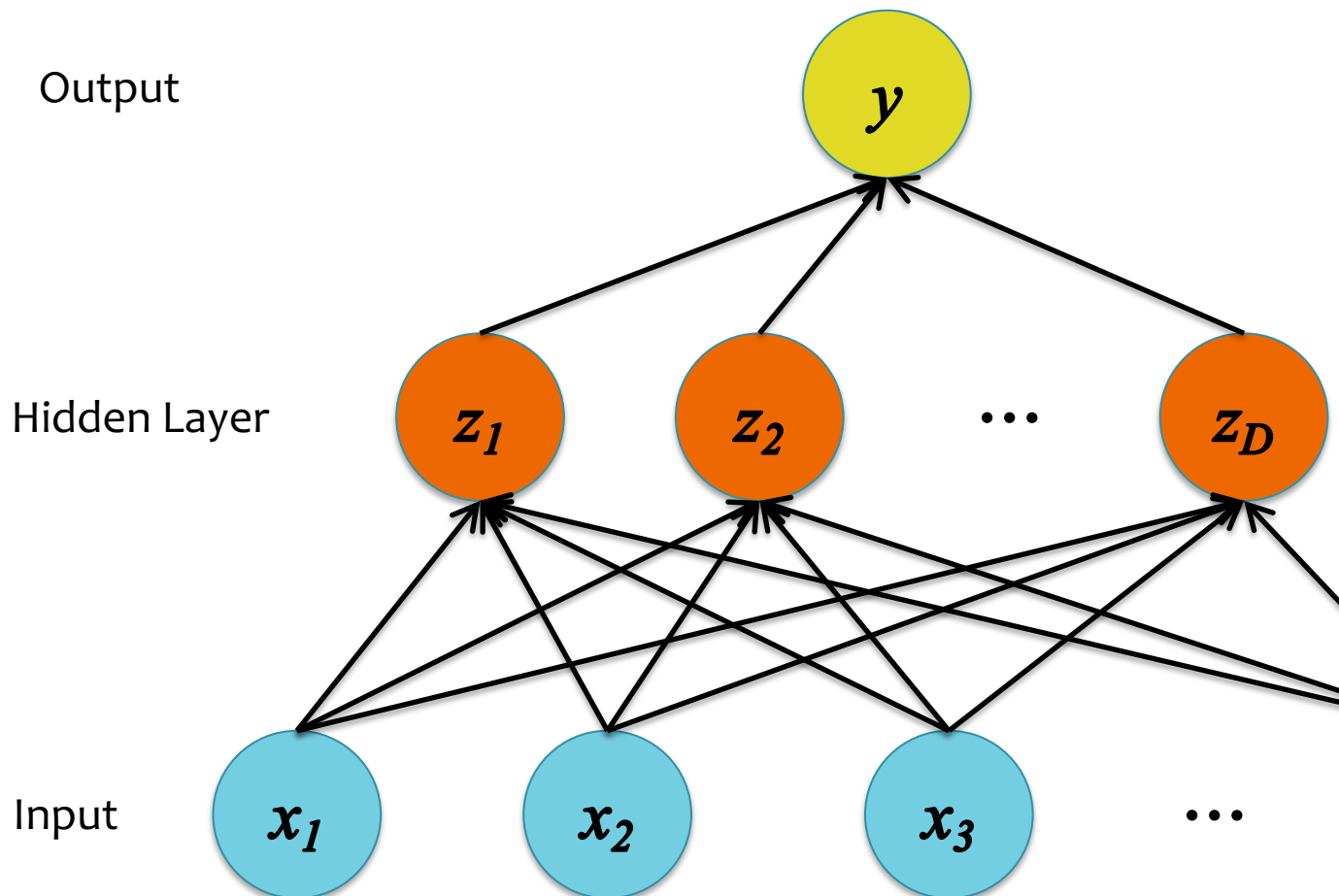

The hidden units could learn to be...

- a selection of the most useful features
- nonlinear combinations of the features
- a lower dimensional projection of the features
- a higher dimensional projection of the features
- a copy of the input features
- a mix of the above

$D > M$

Building a Neural Net

Q: How many hidden units, D , should we use?

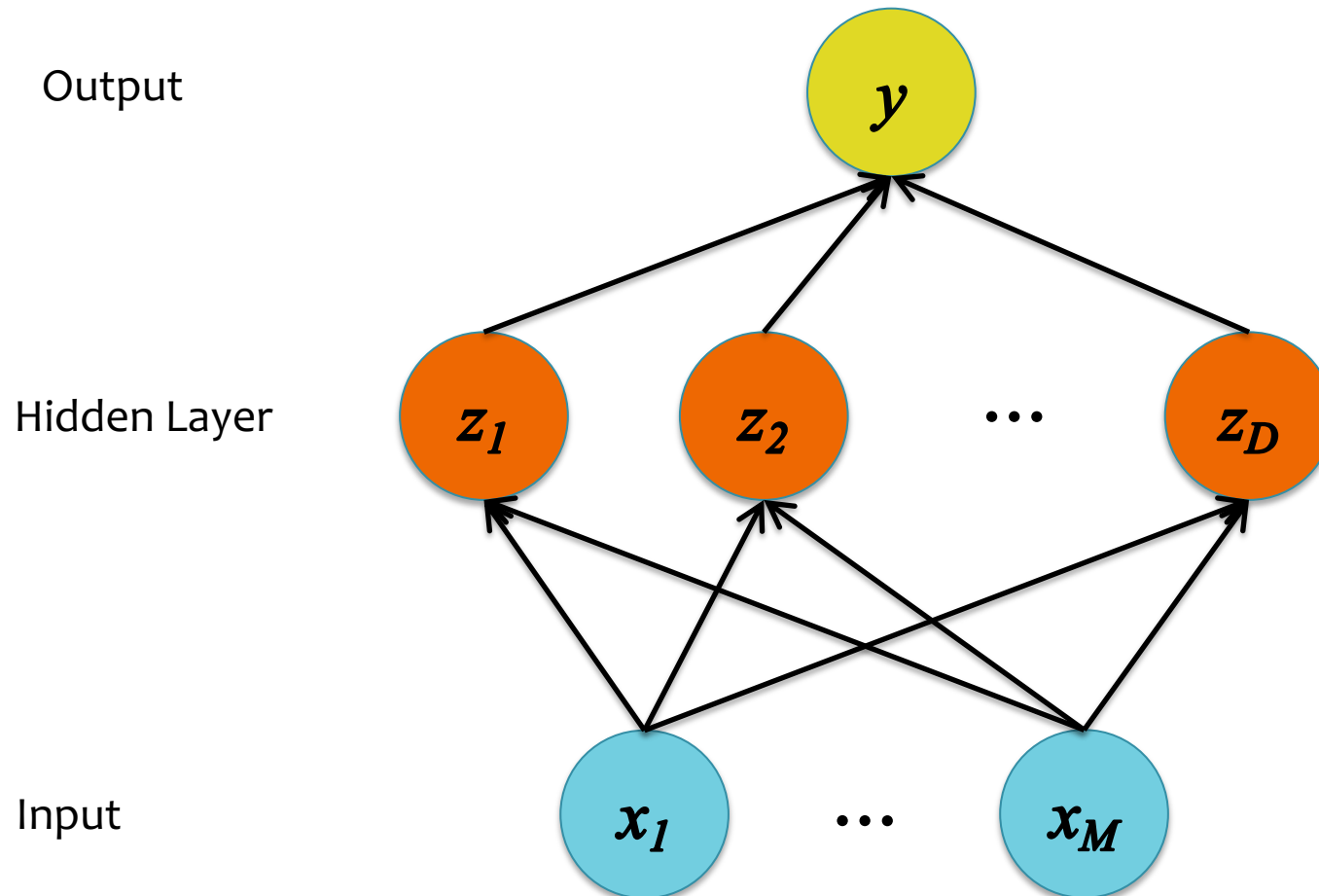

The hidden units could learn to be...

- a selection of the most useful features
- nonlinear combinations of the features
- a lower dimensional projection of the features
- a higher dimensional projection of the features
- a copy of the input features
- a mix of the above

$$D \geq M$$

Building a Neural Net

In the following examples, we have two input features, $M=2$, and we vary the number of hidden units, D .

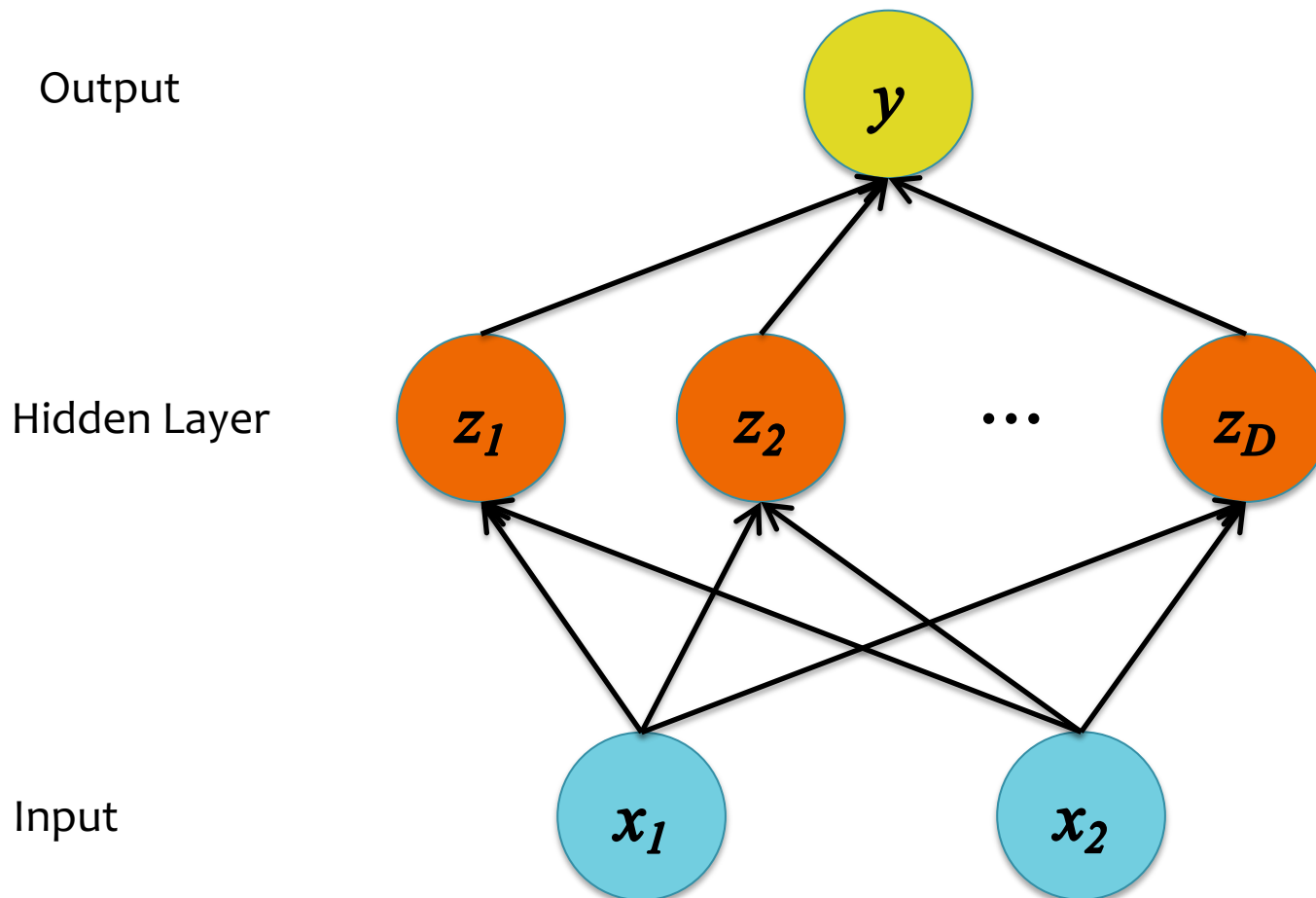

The hidden units could learn to be...

- a selection of the most useful features
- nonlinear combinations of the features
- a lower dimensional projection of the features
- a higher dimensional projection of the features
- a copy of the input features
- a mix of the above

Examples 1 and 2

DECISION BOUNDARY EXAMPLES

Example #1: Diagonal Band

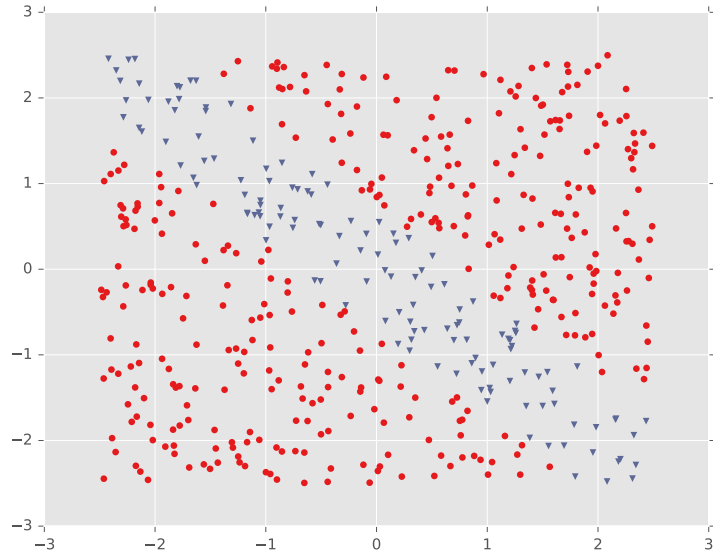

Example #2: One Pocket

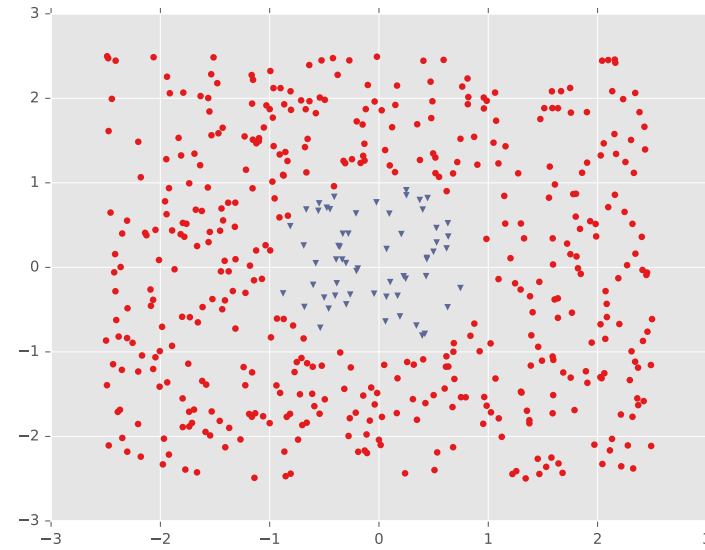

Example #3: Four Gaussians



Example #4: Two Pockets

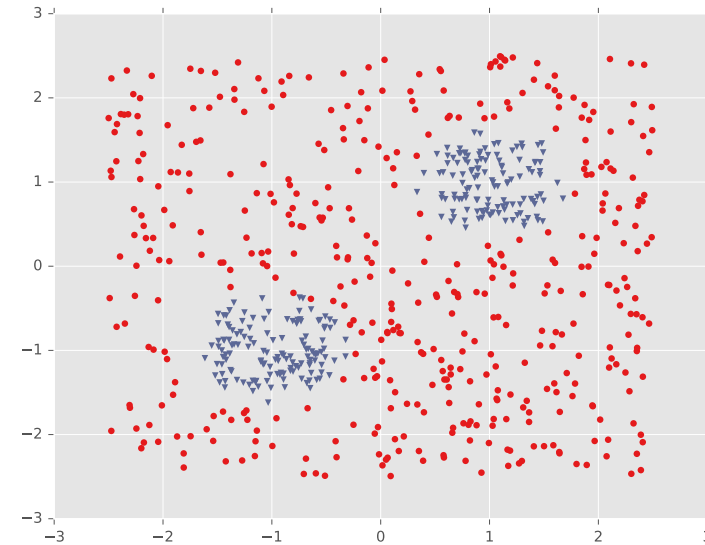

Example #1: Diagonal Band

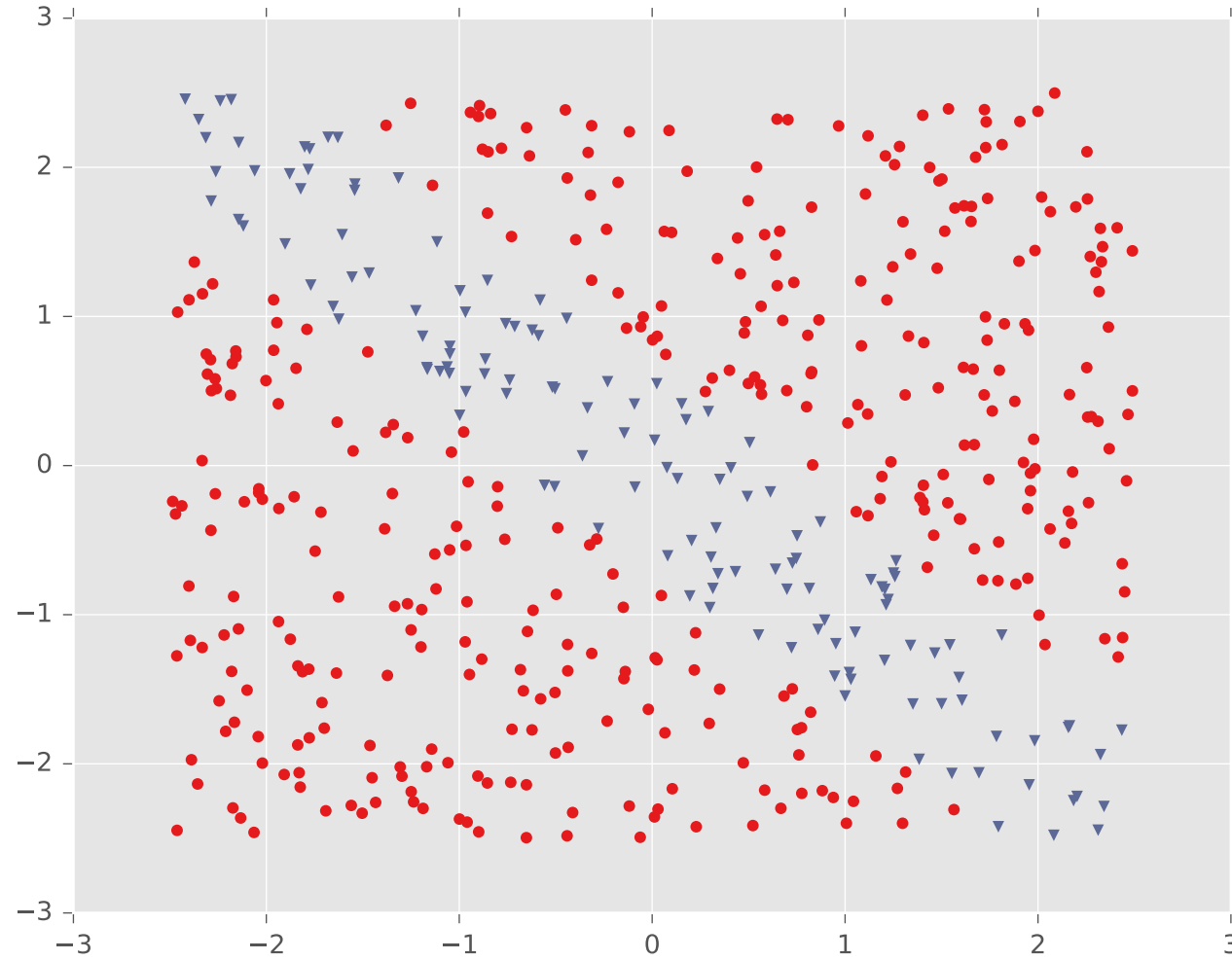

Example #1: Diagonal Band



Example #1: Diagonal Band

Tuned Neural Network (hidden=2, activation=logistic)

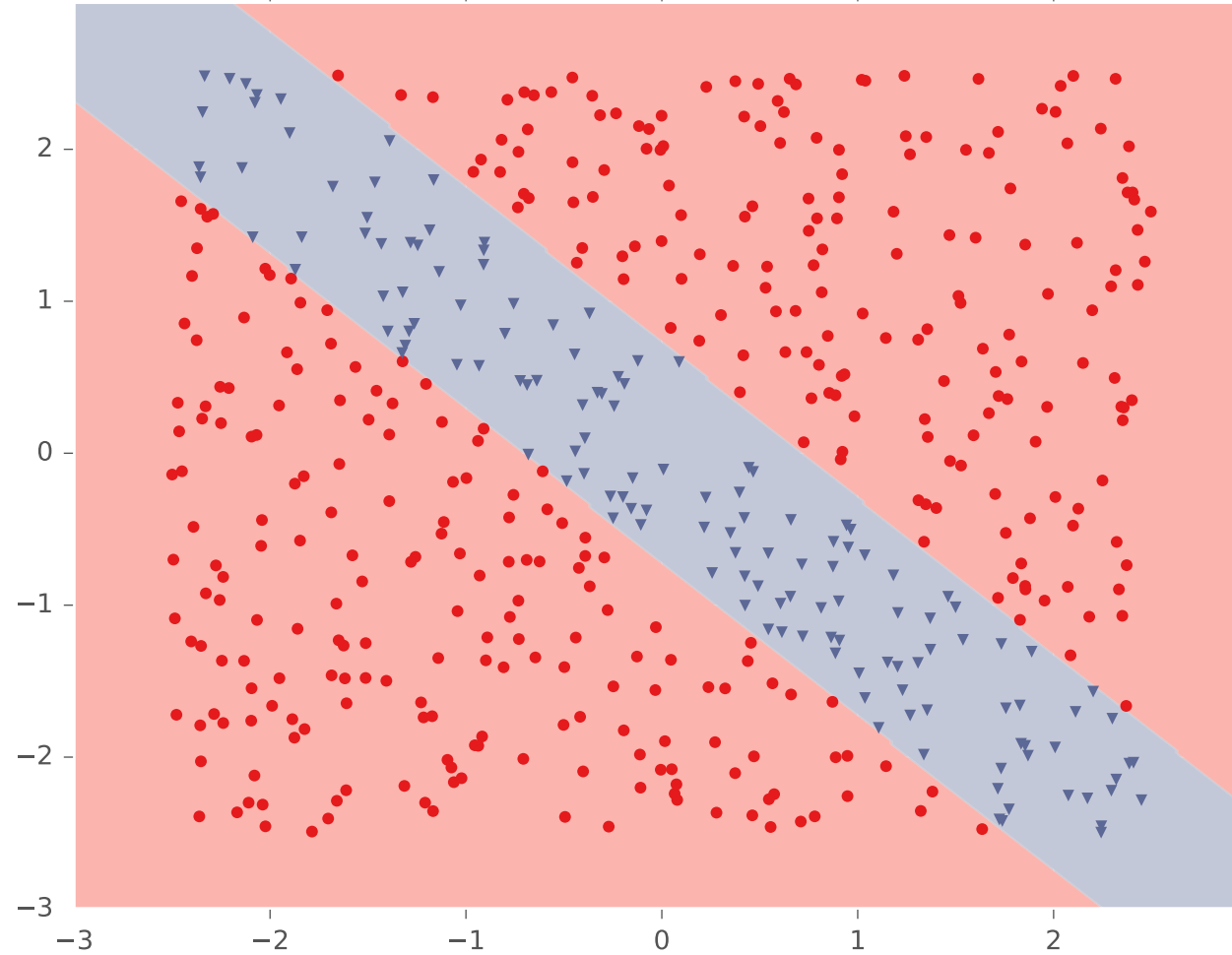

Example #1: Diagonal Band

LR1 for Tuned Neural Network (hidden=2, activation=logistic)

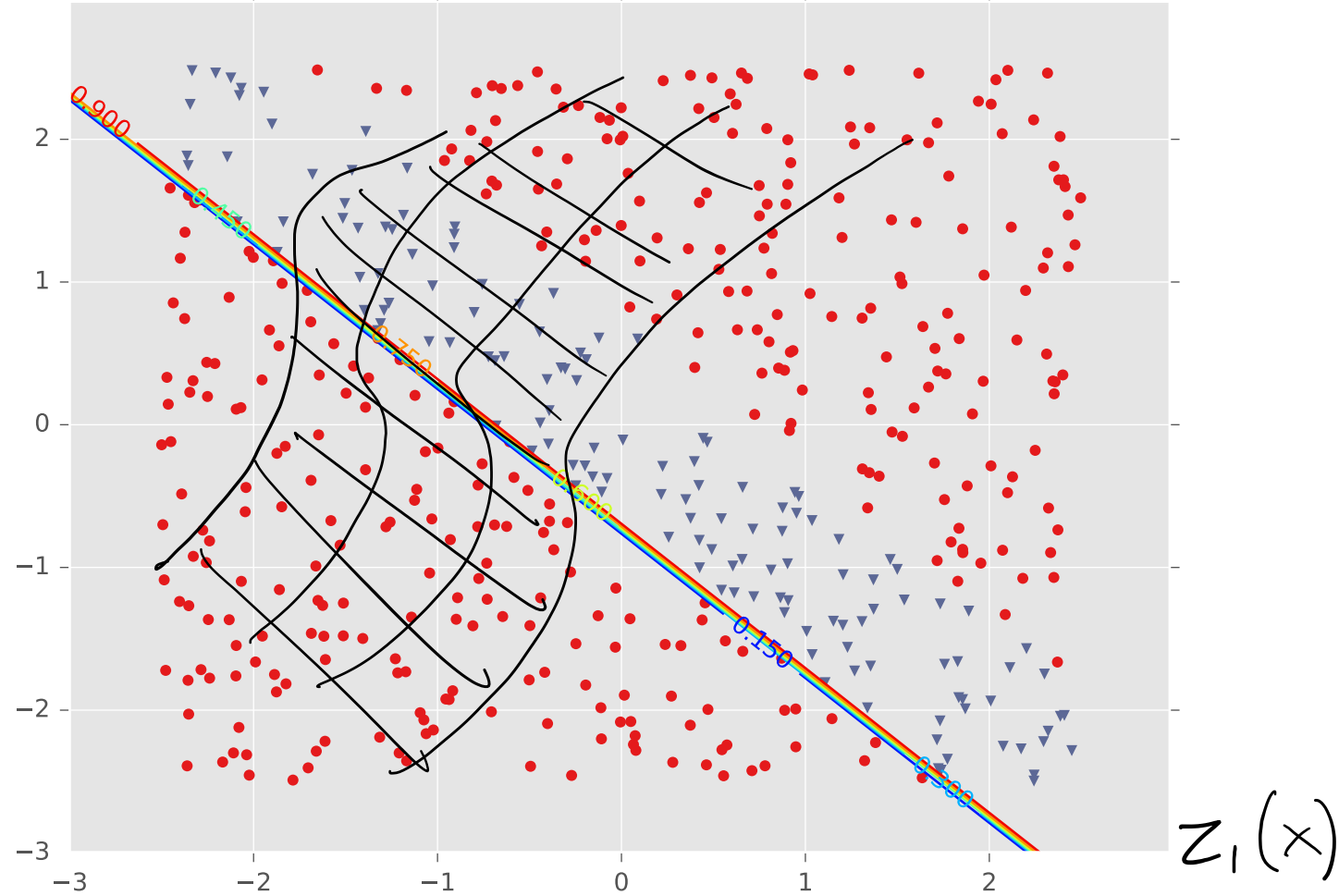

Example #1: Diagonal Band

LR2 for Tuned Neural Network (hidden=2, activation=logistic)

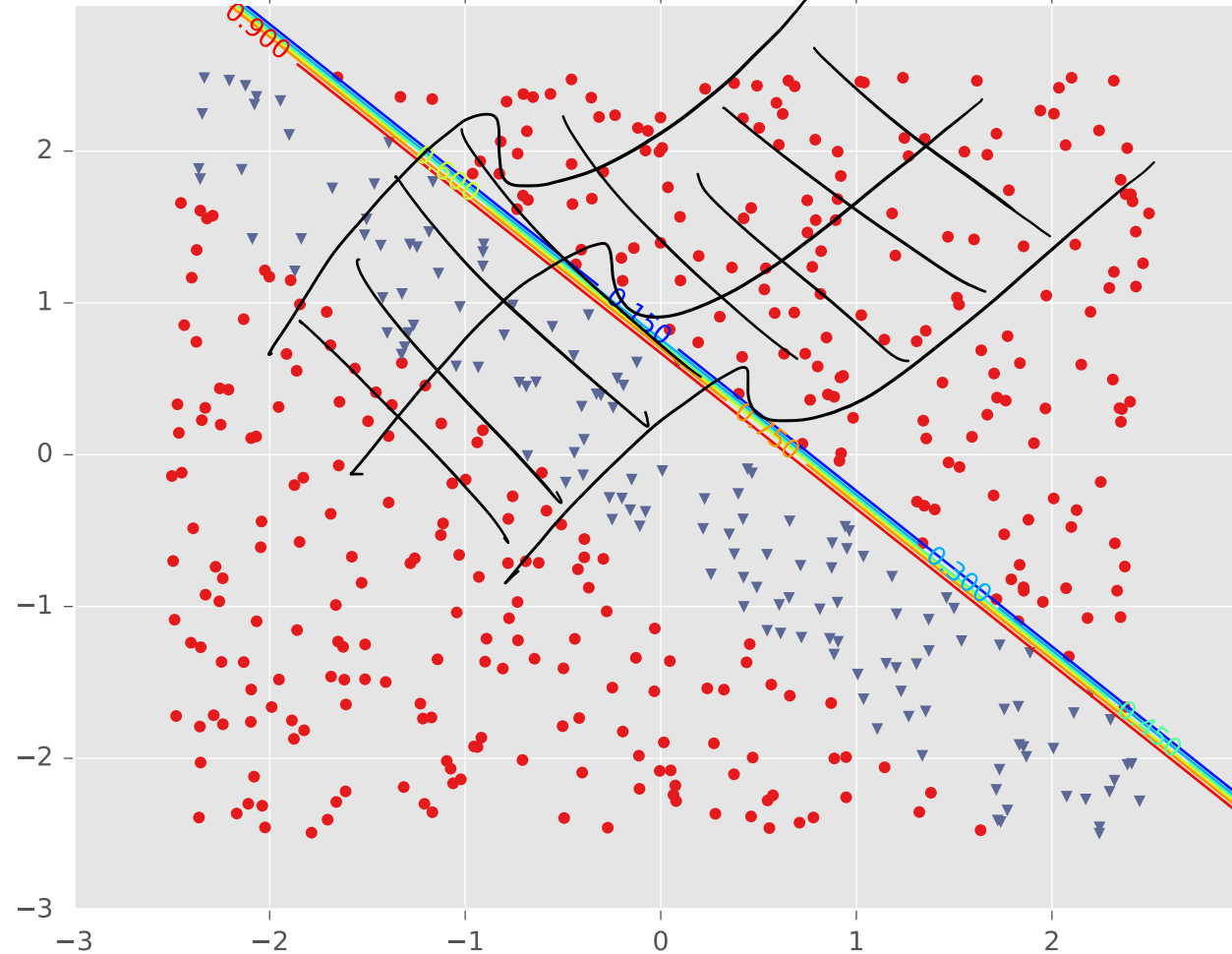

$$z_2(x)$$

Example #1: Diagonal Band

Tuned Neural Network (hidden=2, activation=logistic)

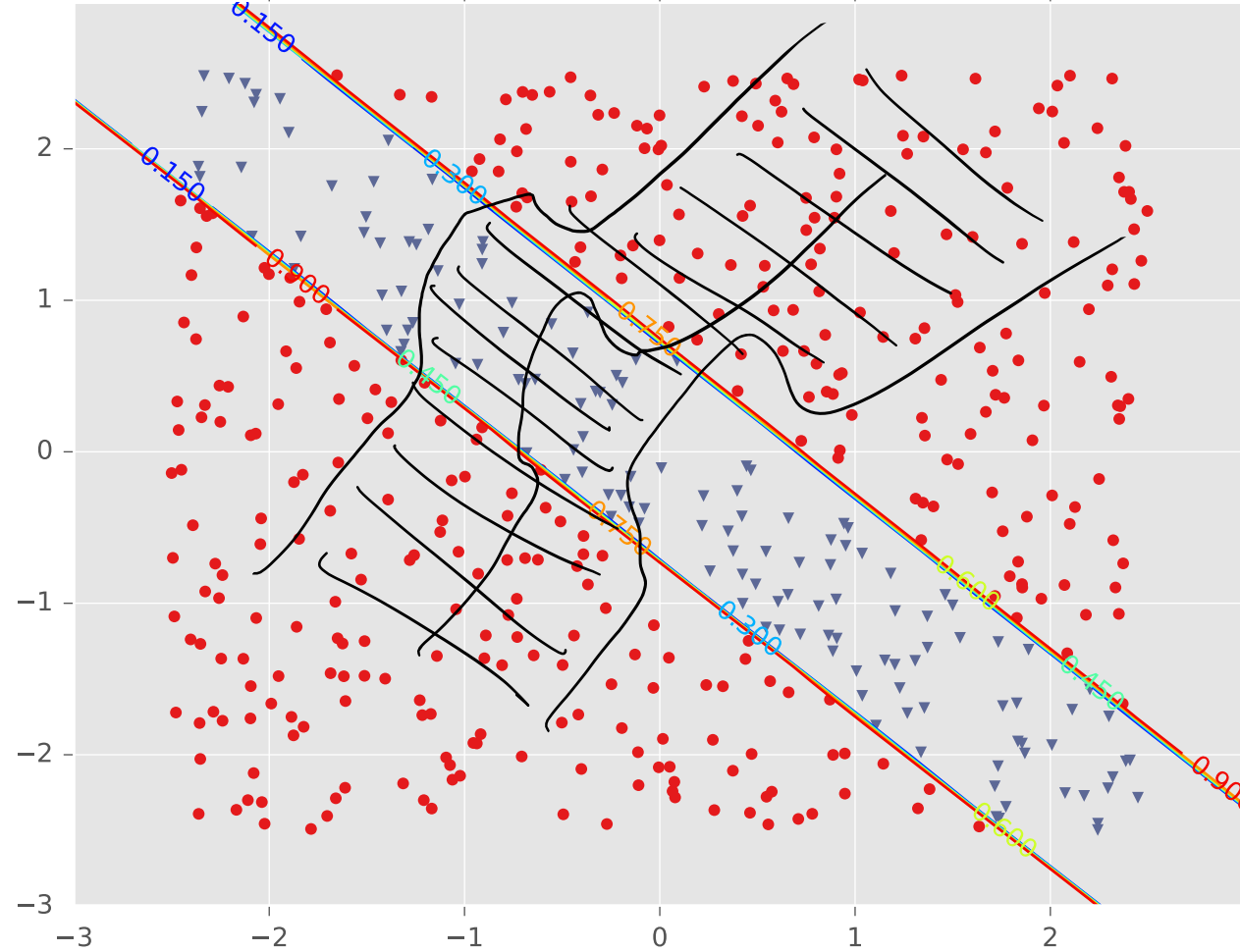

$y(x)$

Example #1: Diagonal Band

LR1 for Tuned Neural Network (hidden=2, activation=logistic)

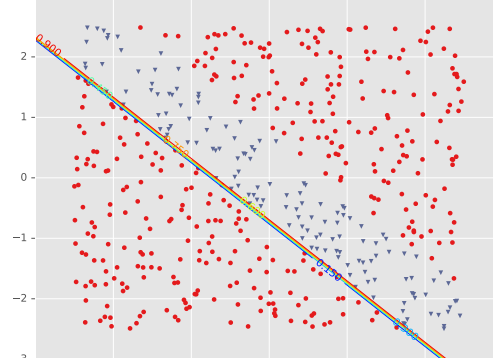

LR2 for Tuned Neural Network (hidden=2, activation=logistic)

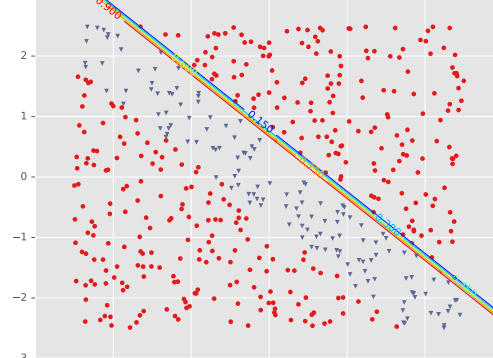

Tuned Neural Network (hidden=2, activation=logistic)

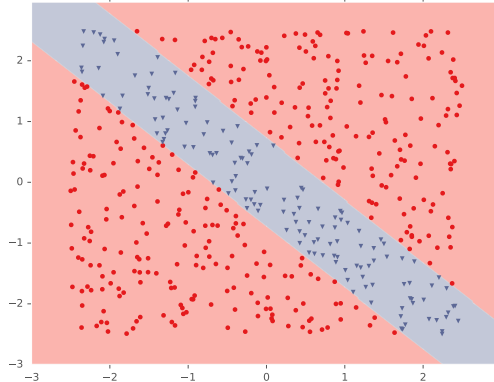

Tuned Neural Network (hidden=2, activation=logistic)

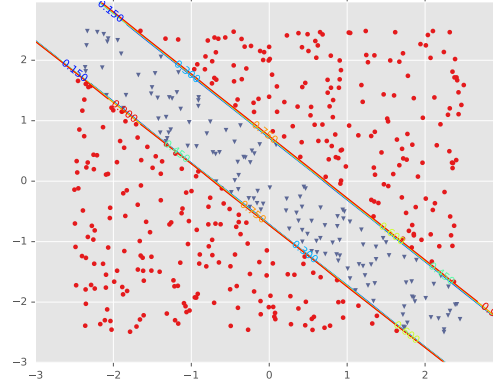

Example #2: One Pocket

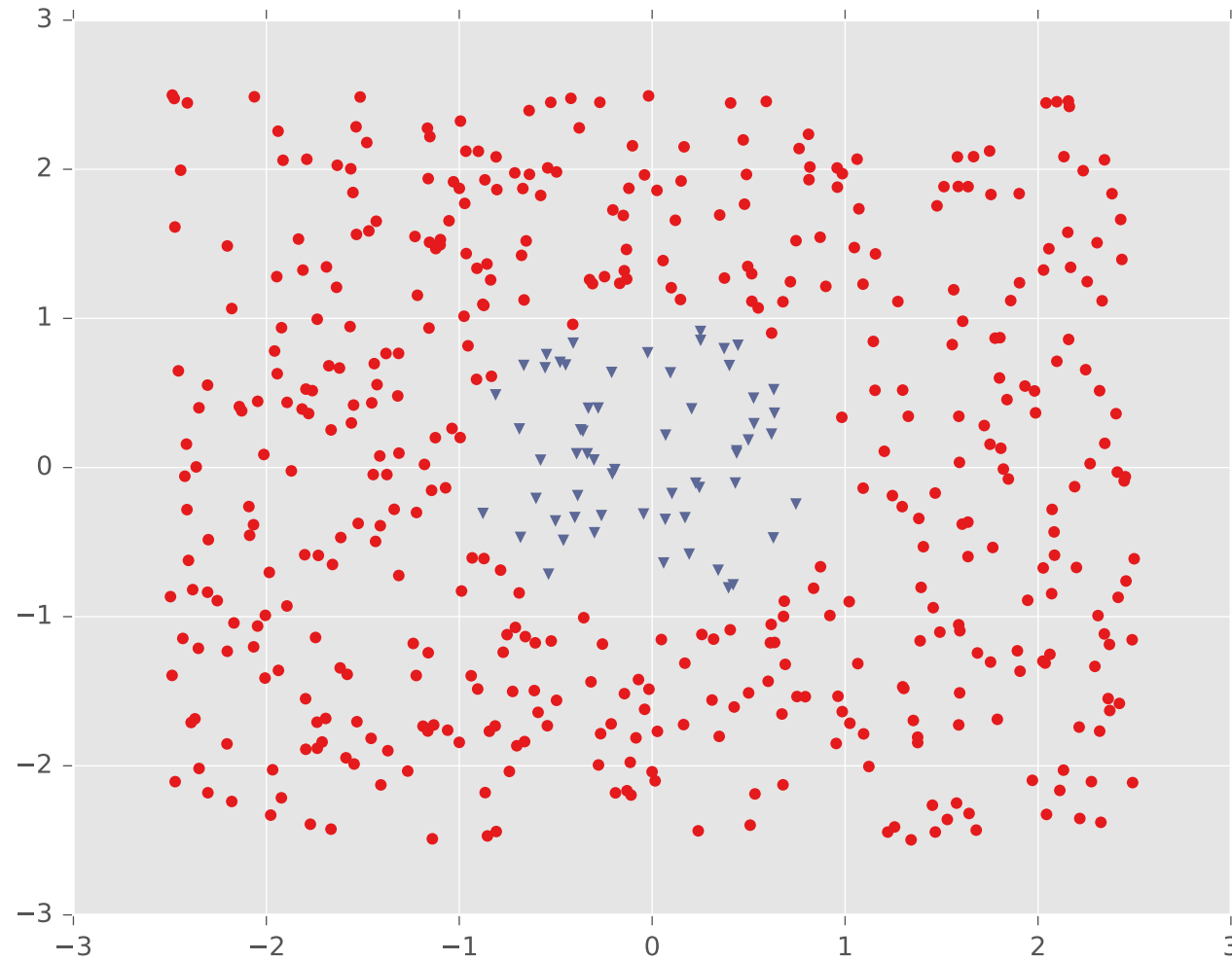

Example #2: One Pocket



Example #2: One Pocket

Tuned Neural Network (hidden=3, activation=logistic)

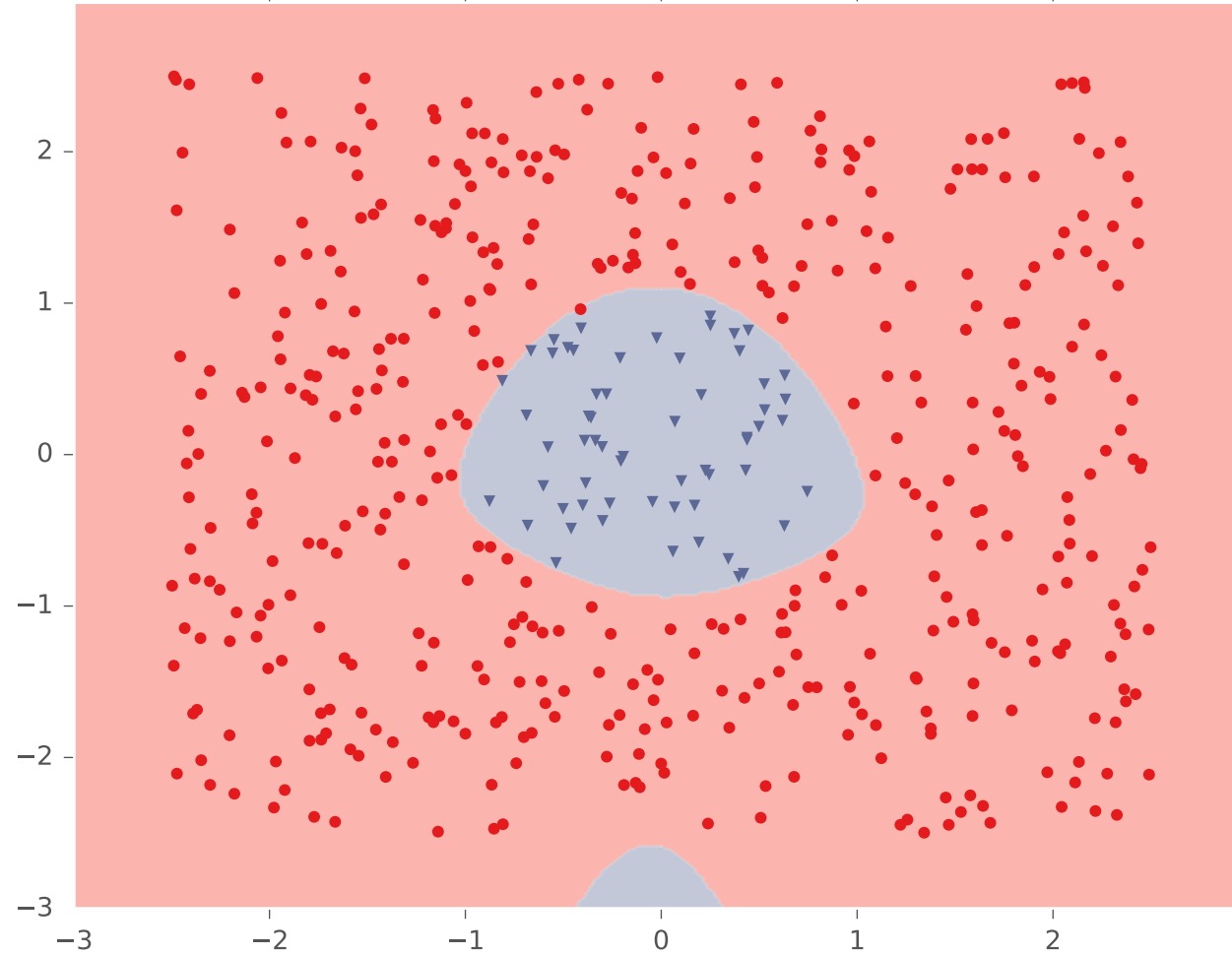

Example #2: One Pocket

LR1 for Tuned Neural Network (hidden=3, activation=logistic)

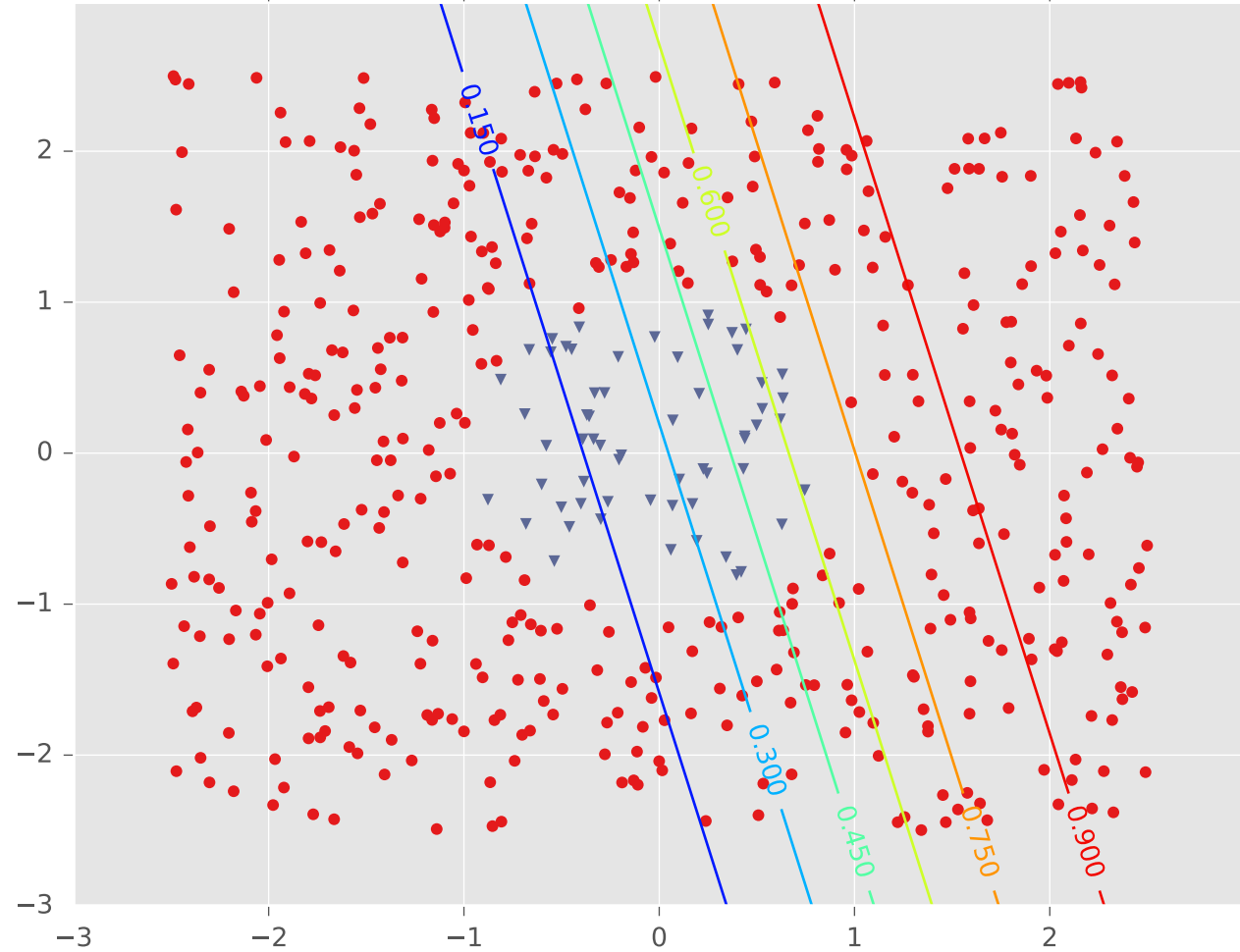

Example #2: One Pocket

LR2 for Tuned Neural Network (hidden=3, activation=logistic)

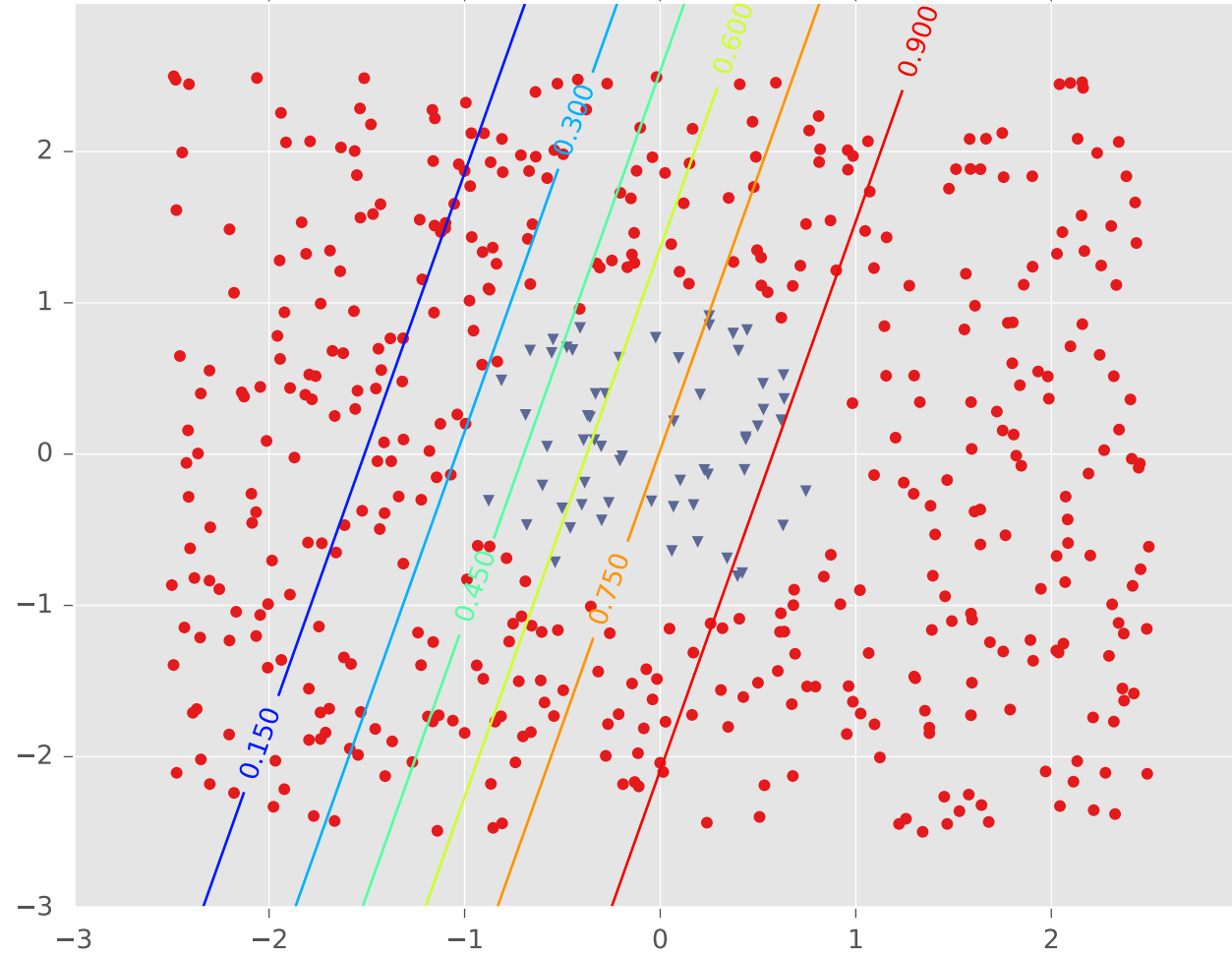

Example #2: One Pocket

LR3 for Tuned Neural Network (hidden=3, activation=logistic)

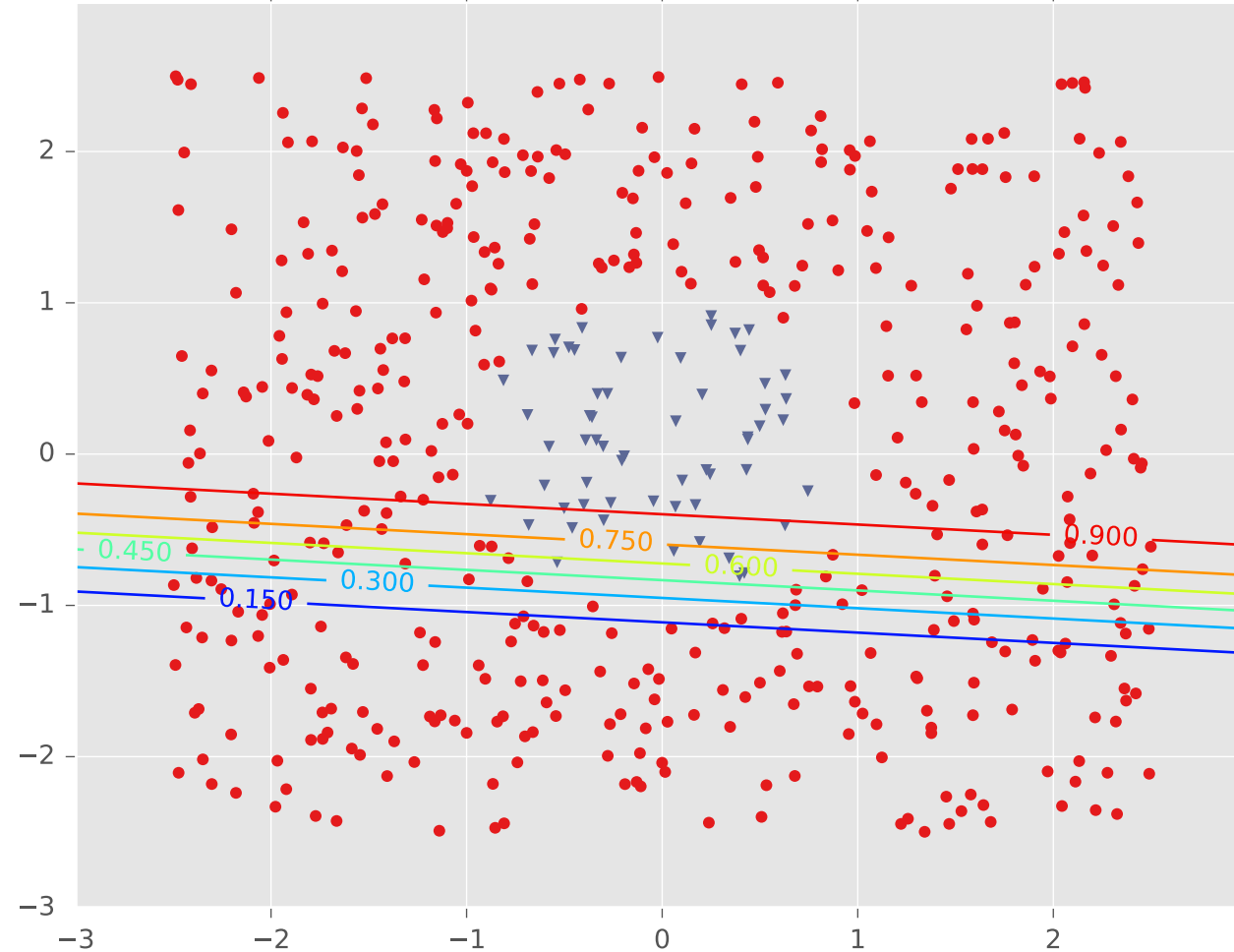

Example #2: One Pocket

Tuned Neural Network (hidden=3, activation=logistic)

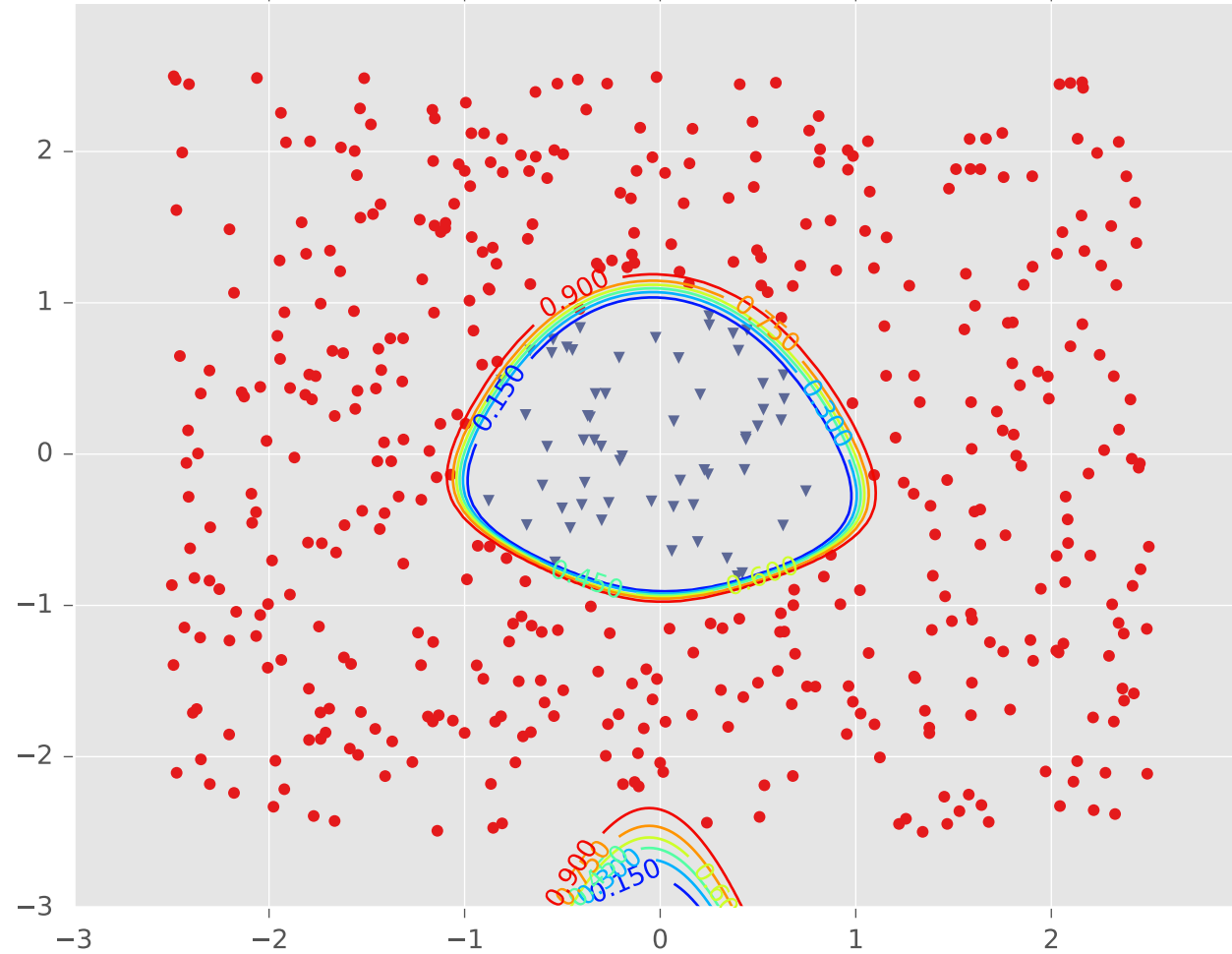

Example #2: One Pocket

LR1 for Tuned Neural Network (hidden=3, activation=logistic)

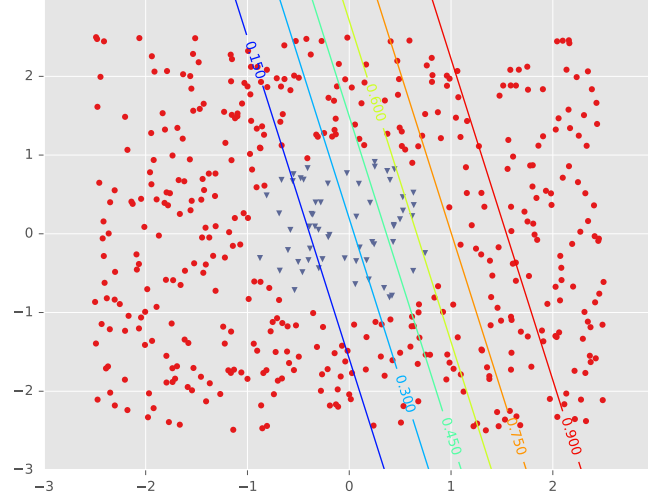

LR2 for Tuned Neural Network (hidden=3, activation=logistic)

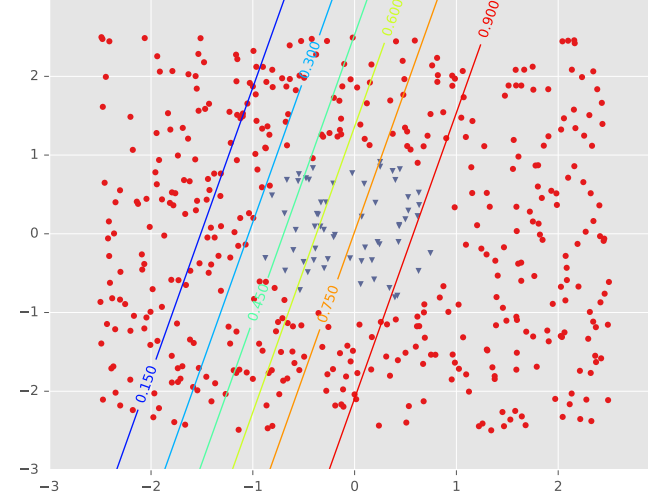

LR3 for Tuned Neural Network (hidden=3, activation=logistic)

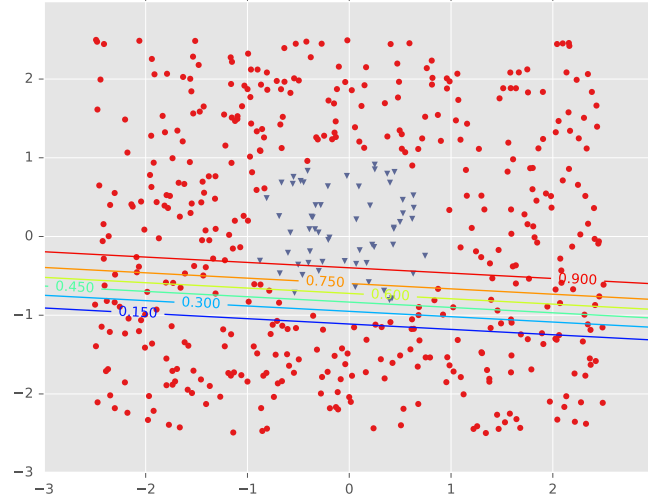

Tuned Neural Network (hidden=3, activation=logistic)

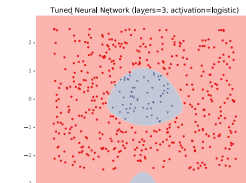
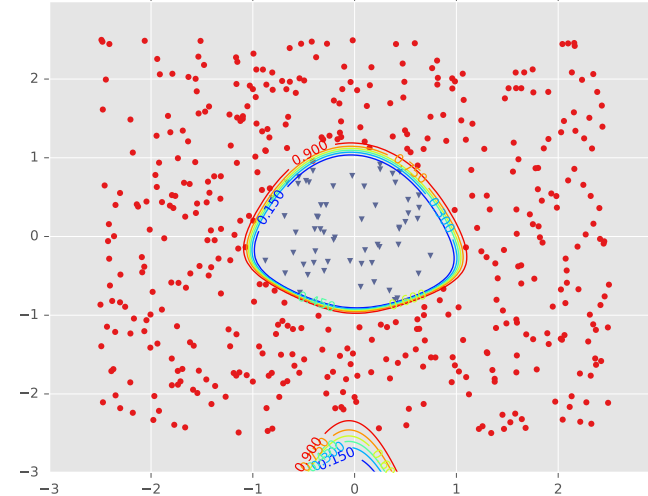

Examples 3 and 4

DECISION BOUNDARY EXAMPLES

Example #1: Diagonal Band

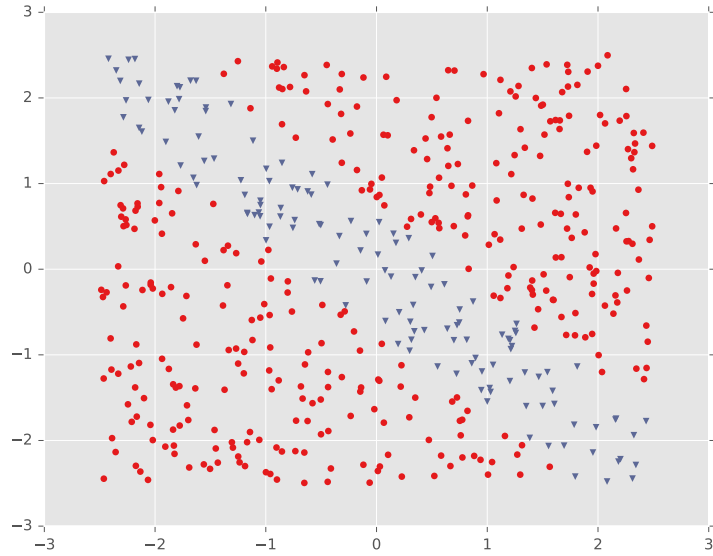

Example #2: One Pocket

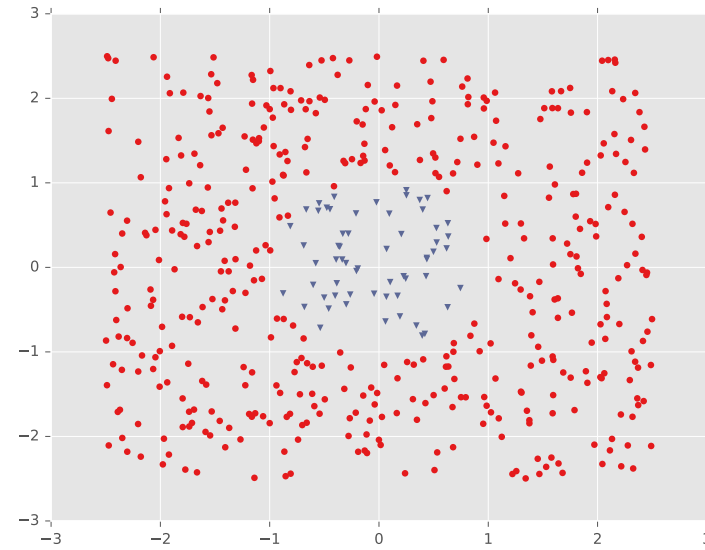

Example #3: Four Gaussians



Example #4: Two Pockets

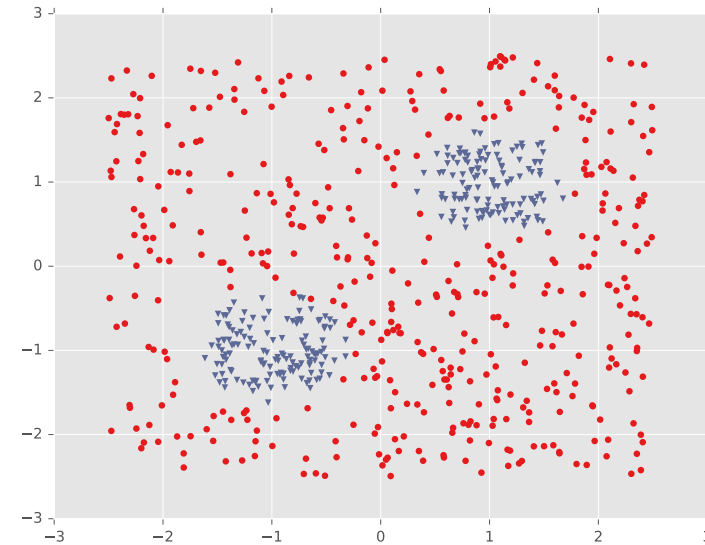

Example #3: Four Gaussians



Example #3: Four Gaussians

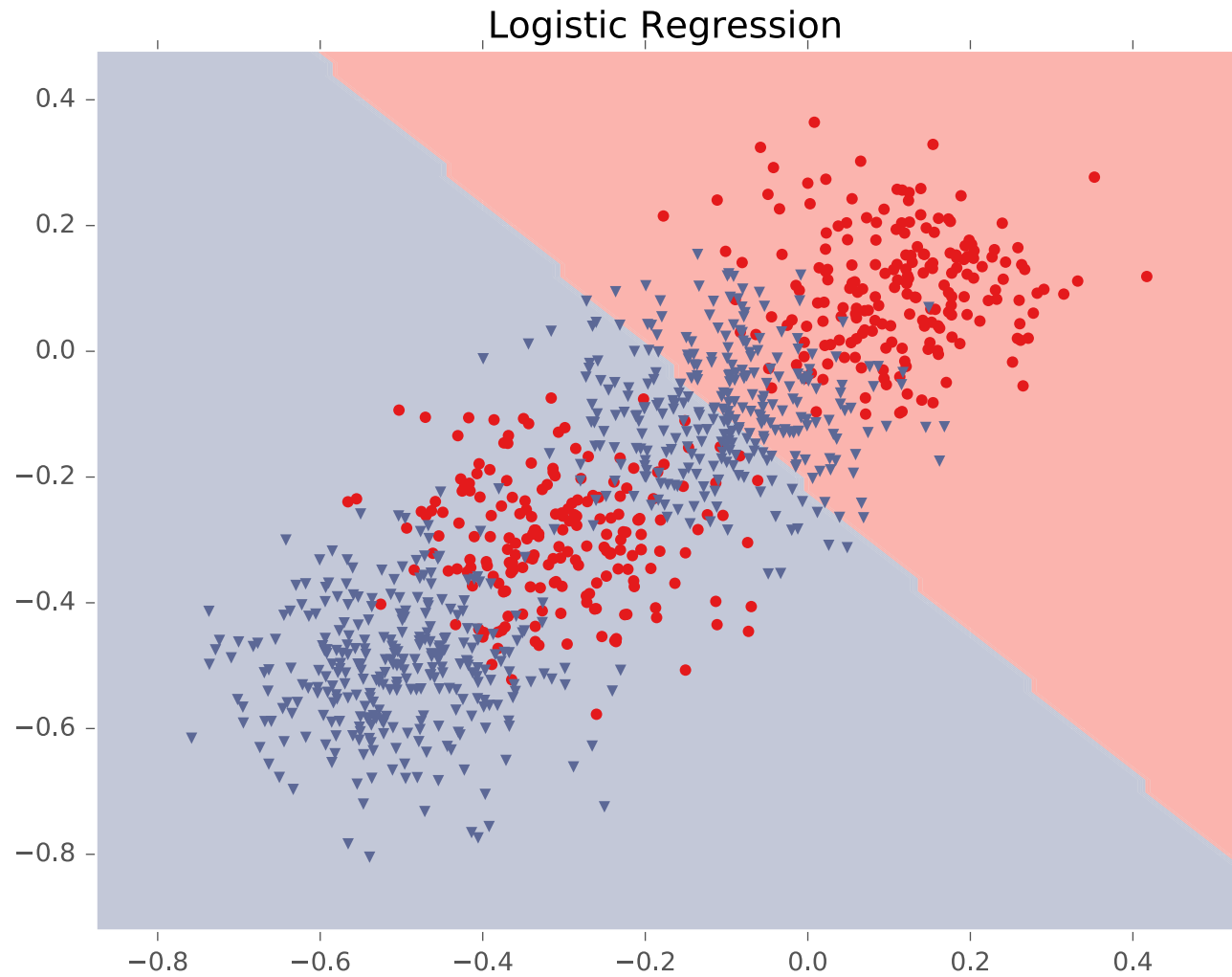

Example #3: Four Gaussians

K-NN (k=5, metric=euclidean)

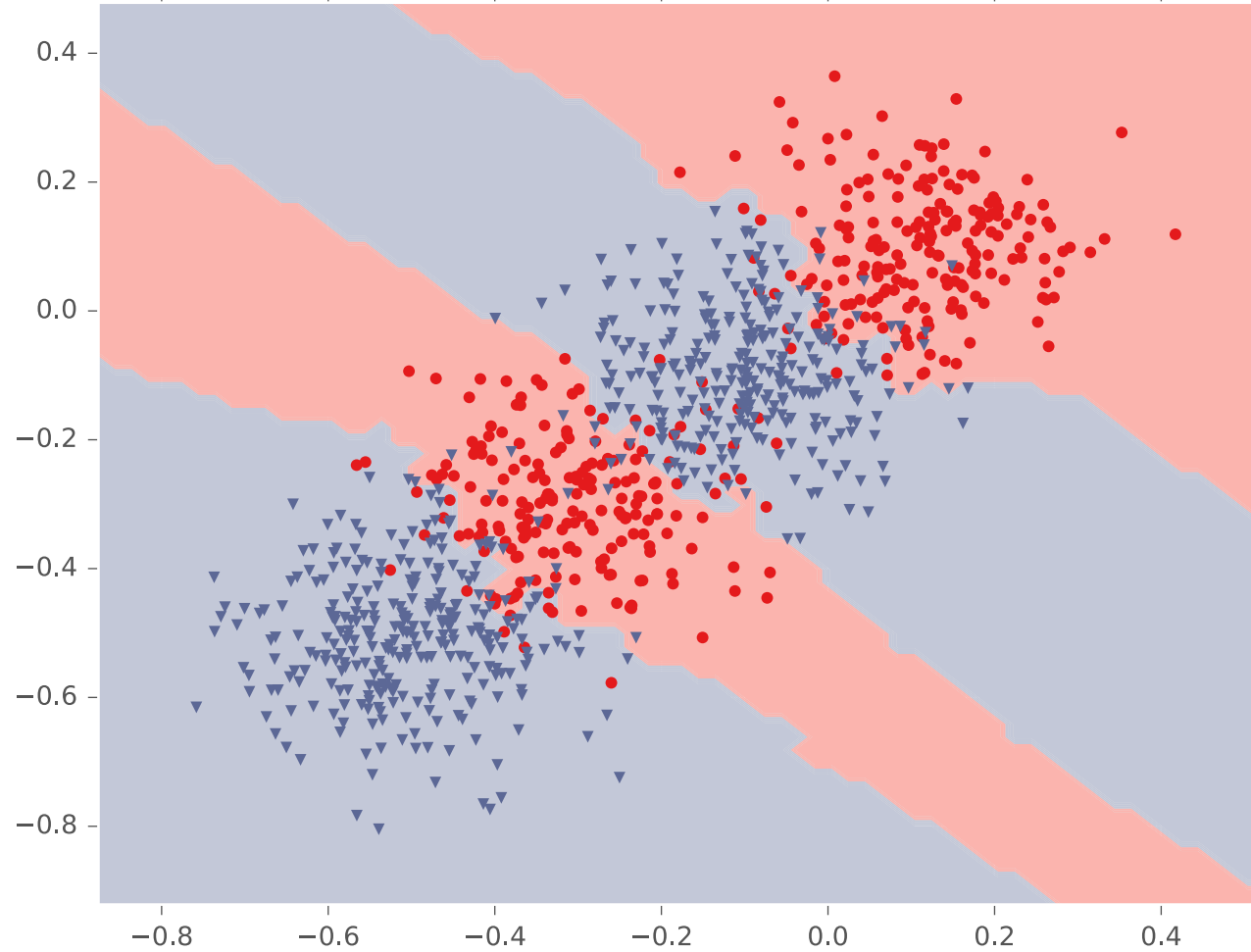

Example #3: Four Gaussians

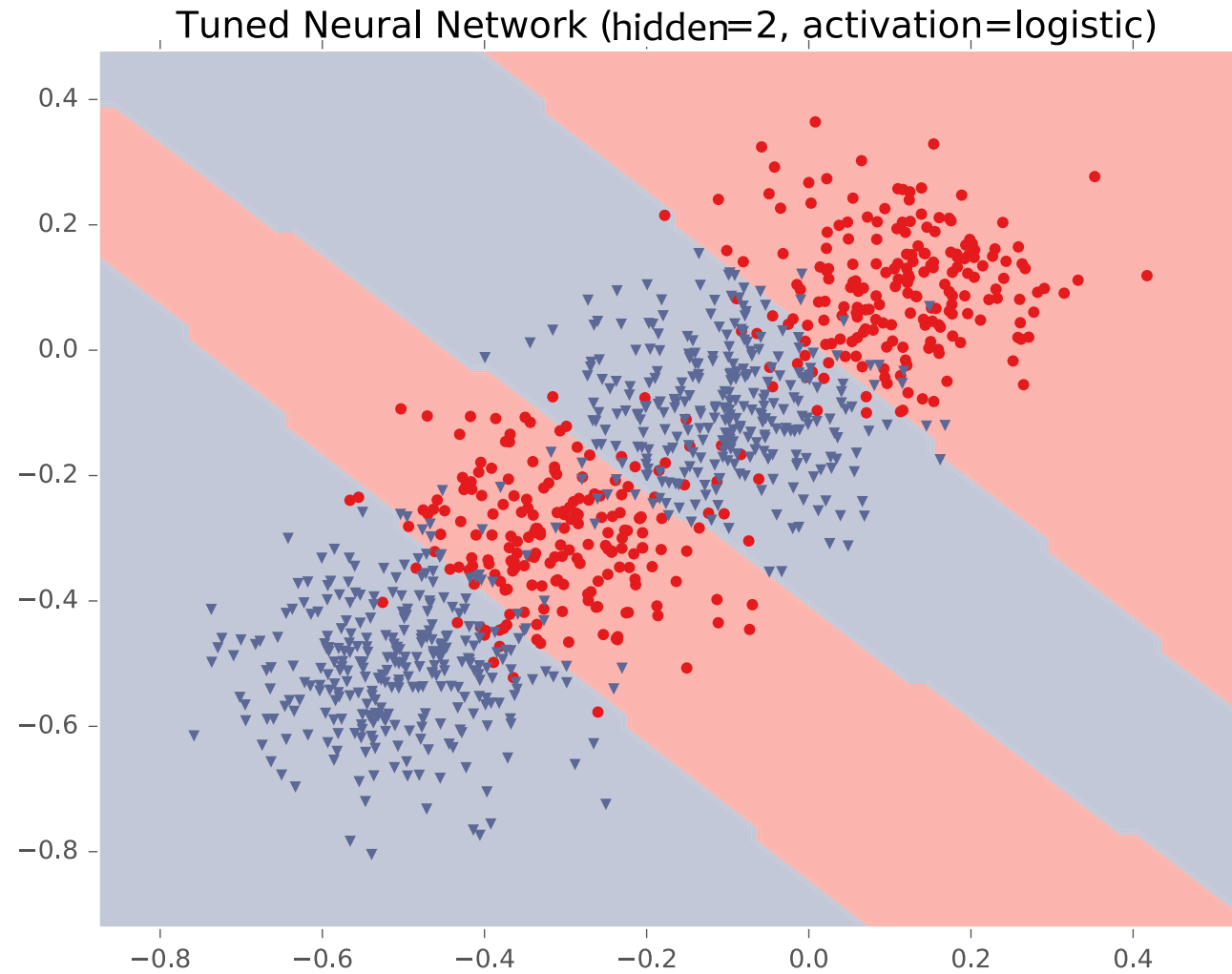

Example #3: Four Gaussians

LR1 for Tuned Neural Network (hidden=2, activation=logistic)

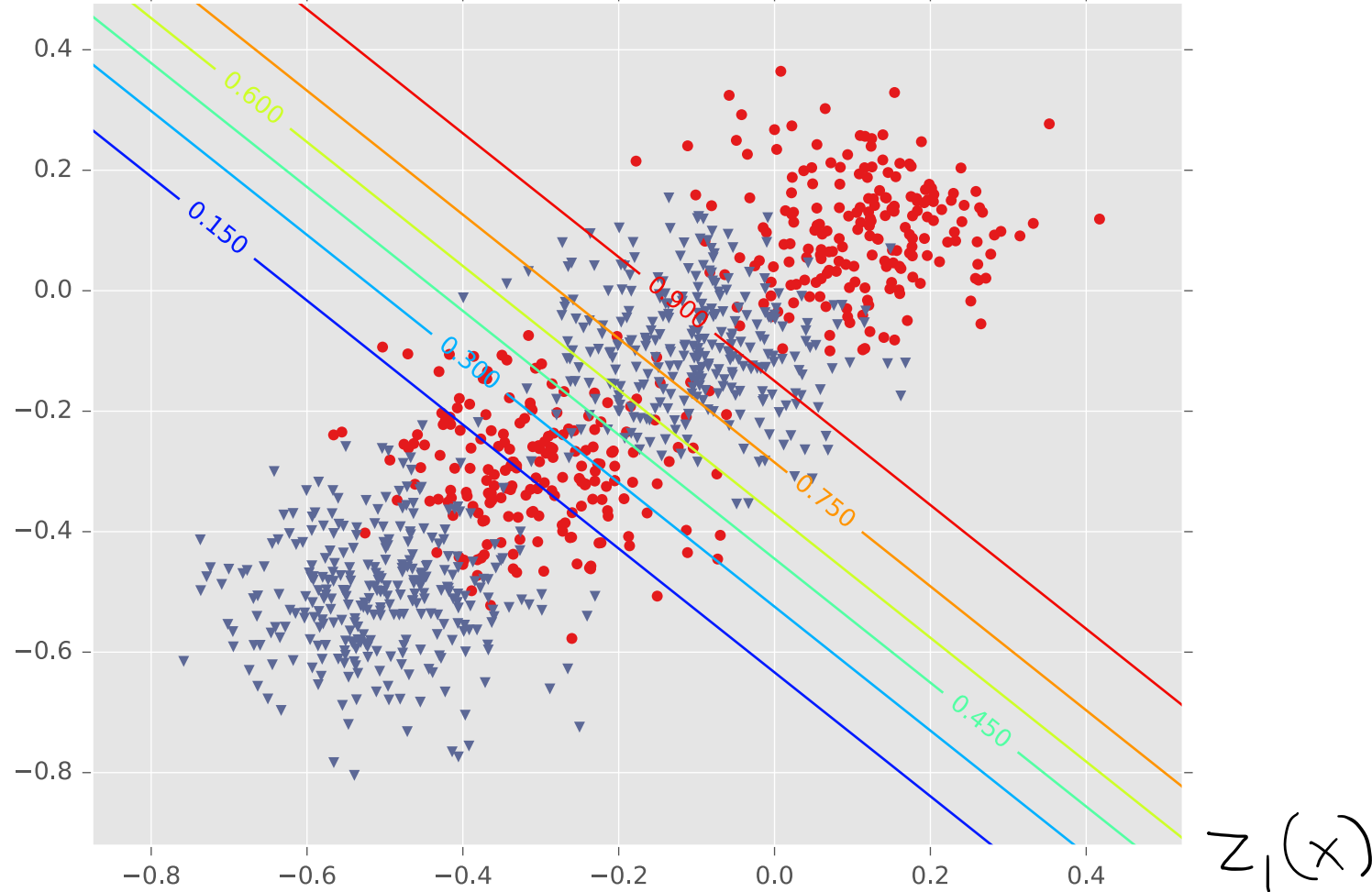

Example #3: Four Gaussians

LR2 for Tuned Neural Network (hidden=2, activation=logistic)

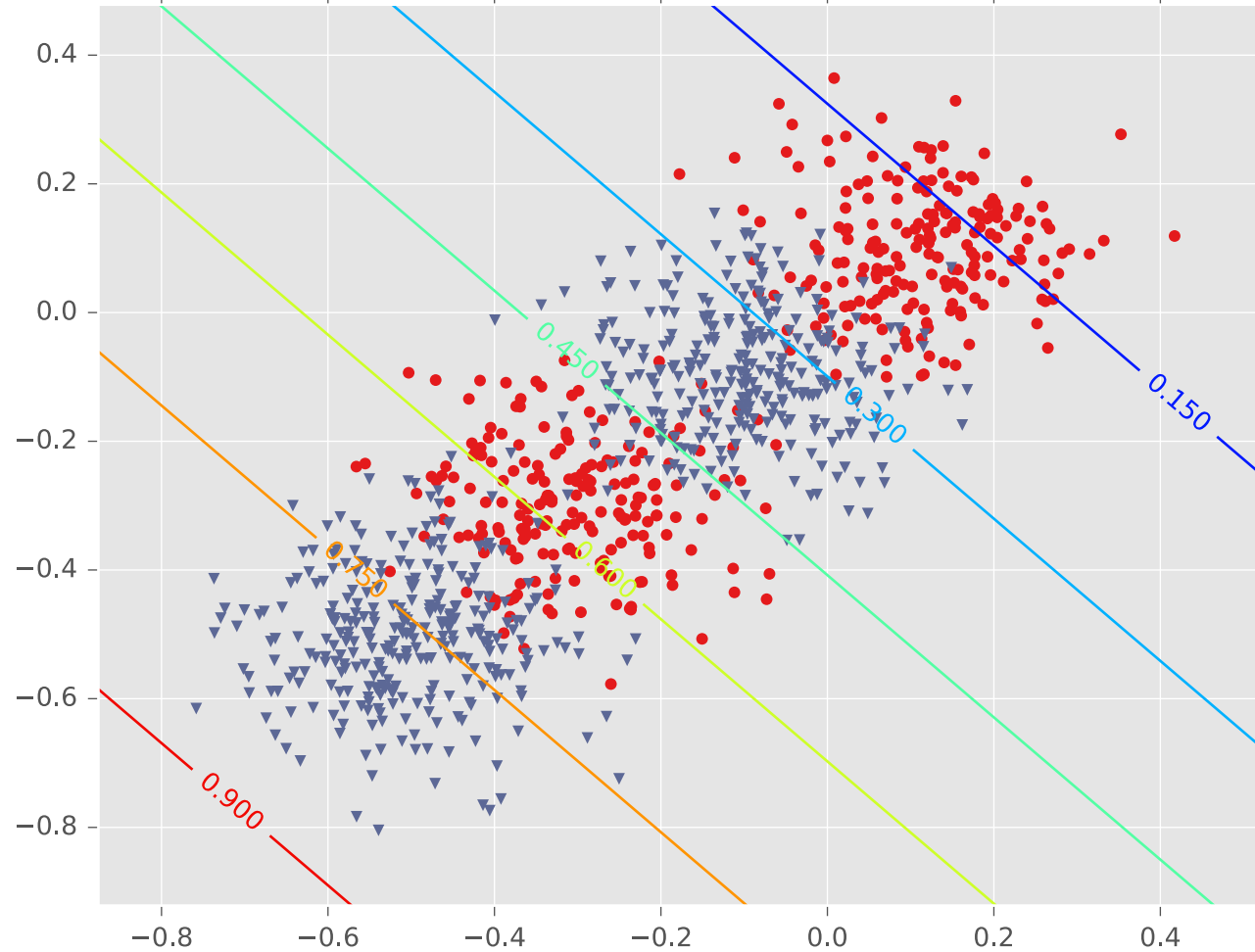

$z_2(x)$

Example #3: Four Gaussians

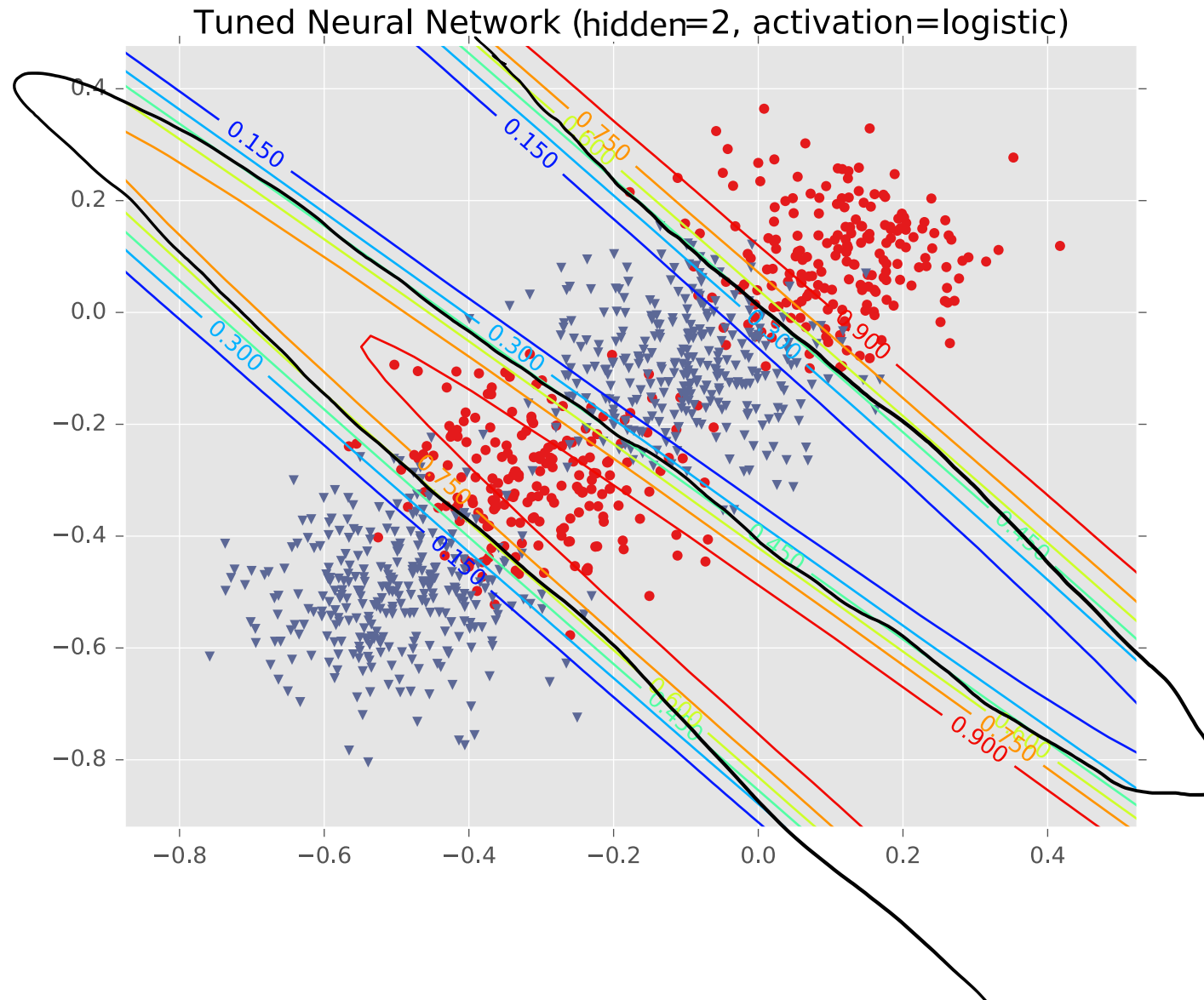

Example #4: Two Pockets

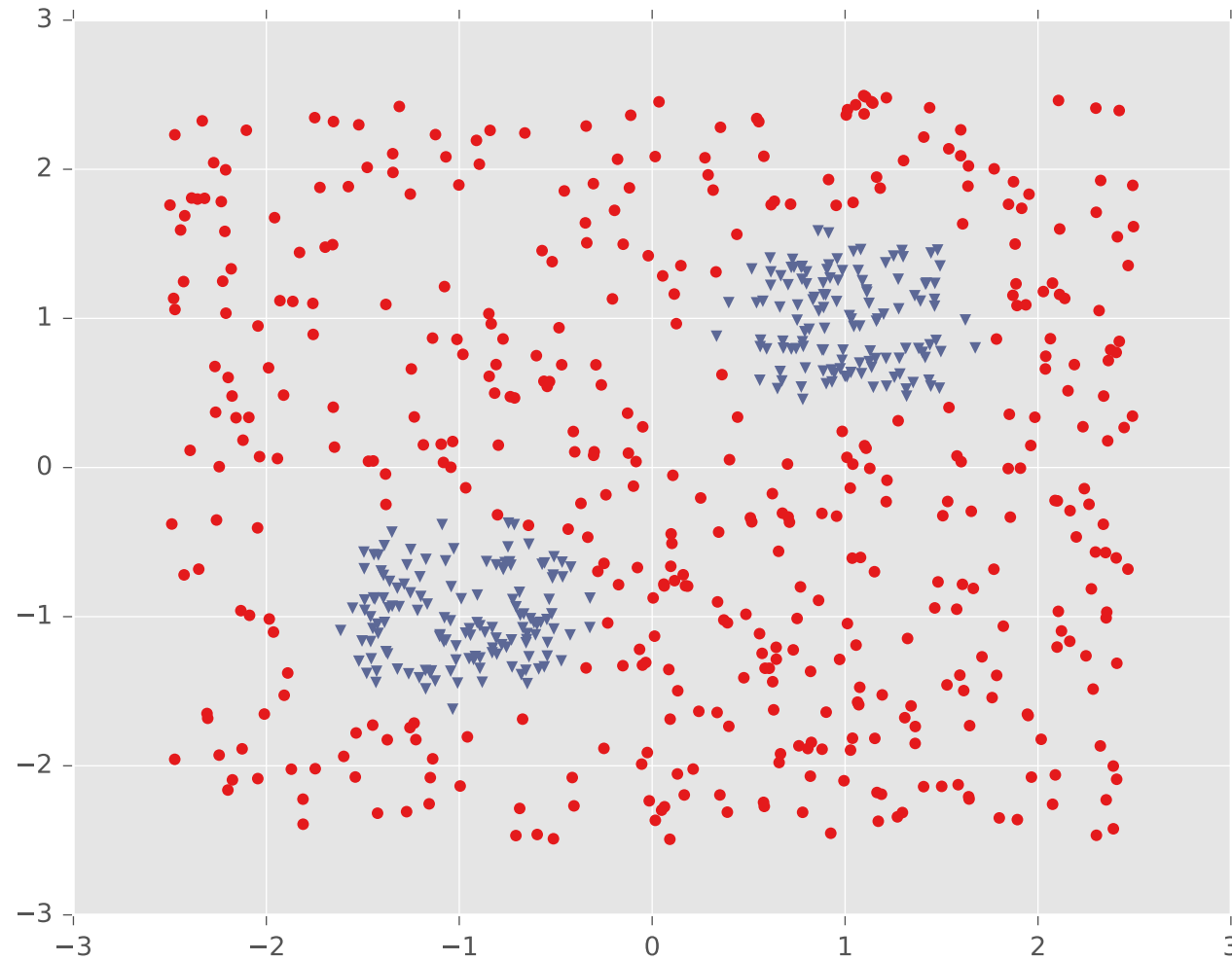

Example #4: Two Pockets

Logistic Regression

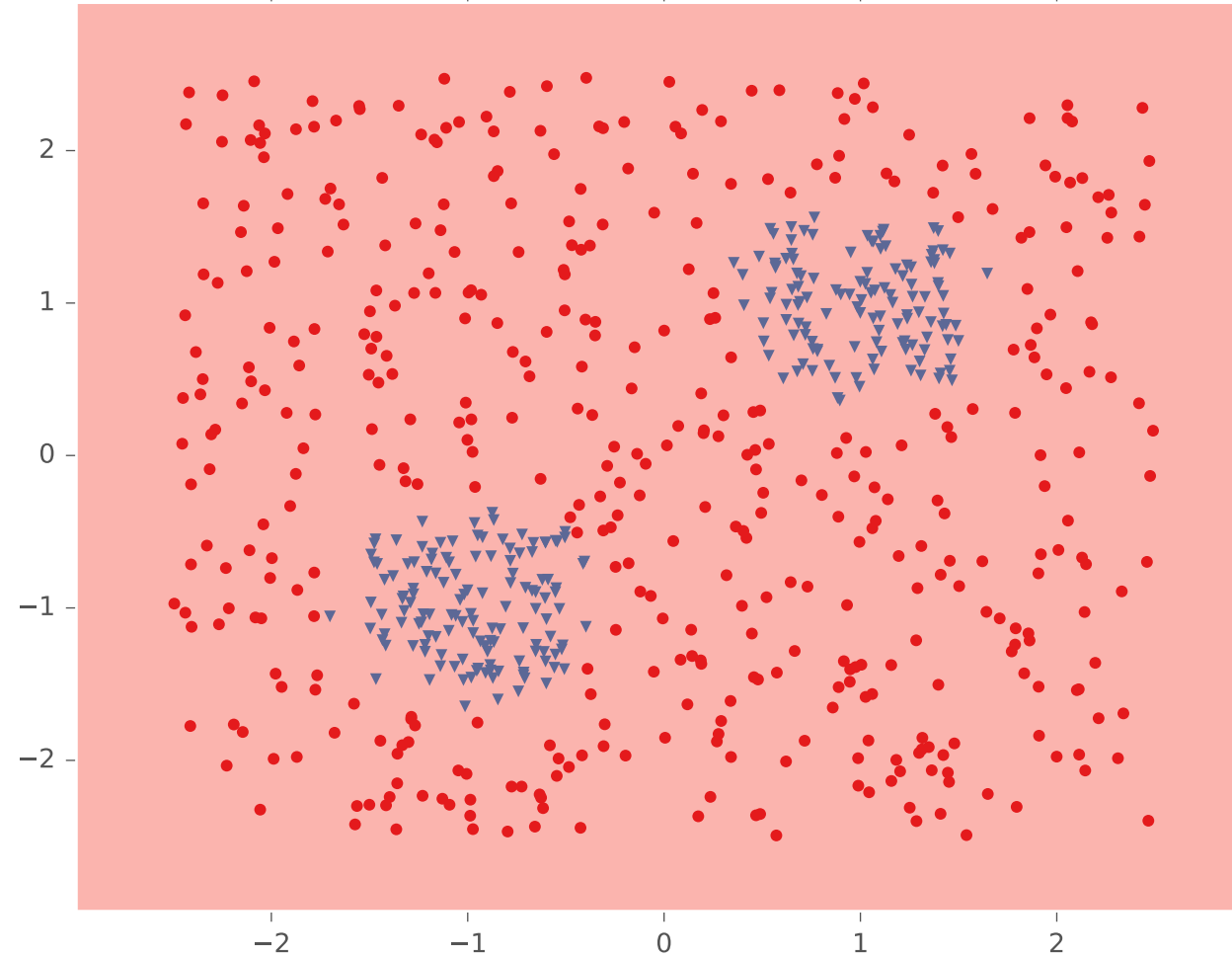

Example #4: Two Pockets

K-NN (k=5, metric=euclidean)

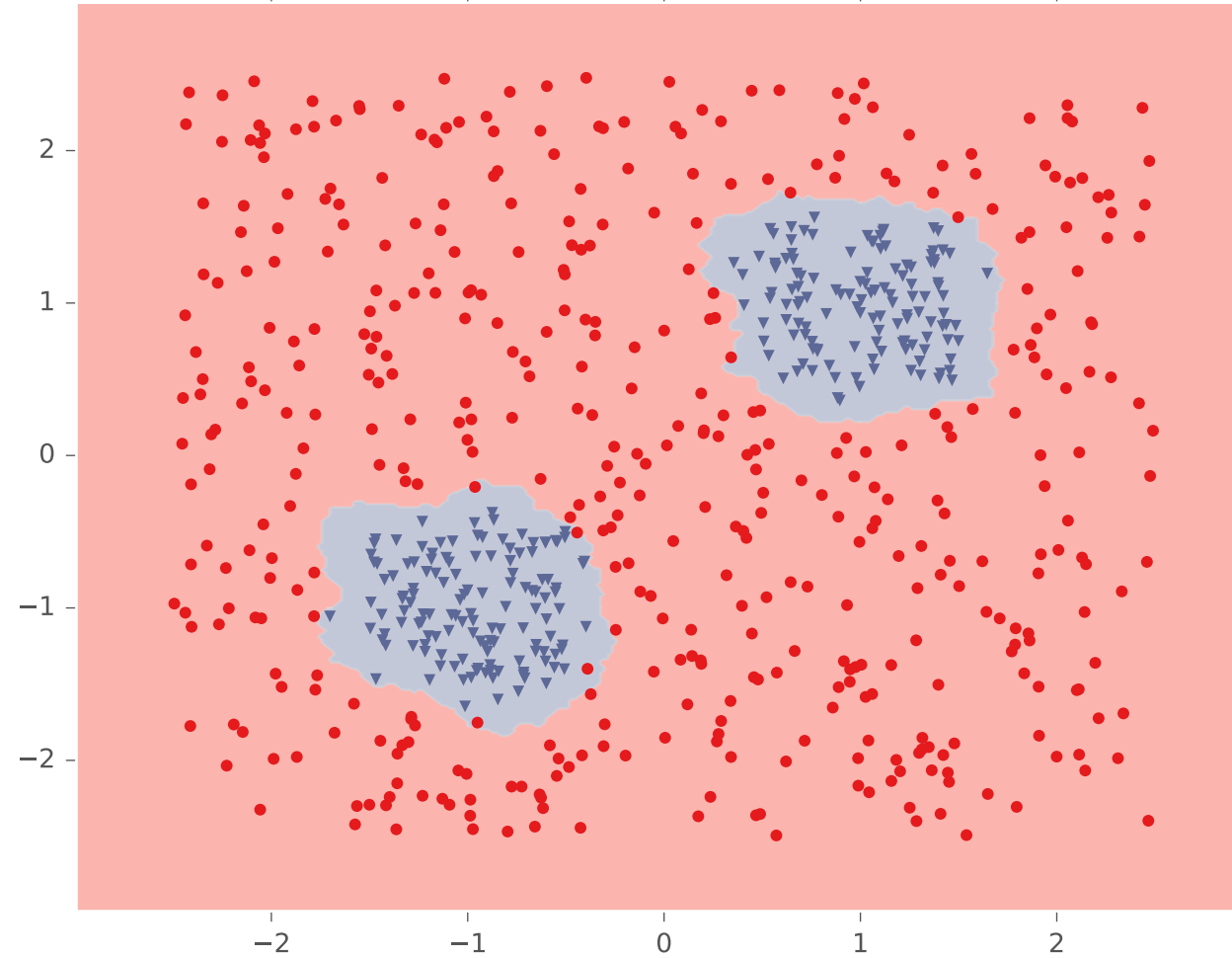

Example #4: Two Pockets

Tuned Neural Network (hidden=2, activation=logistic)

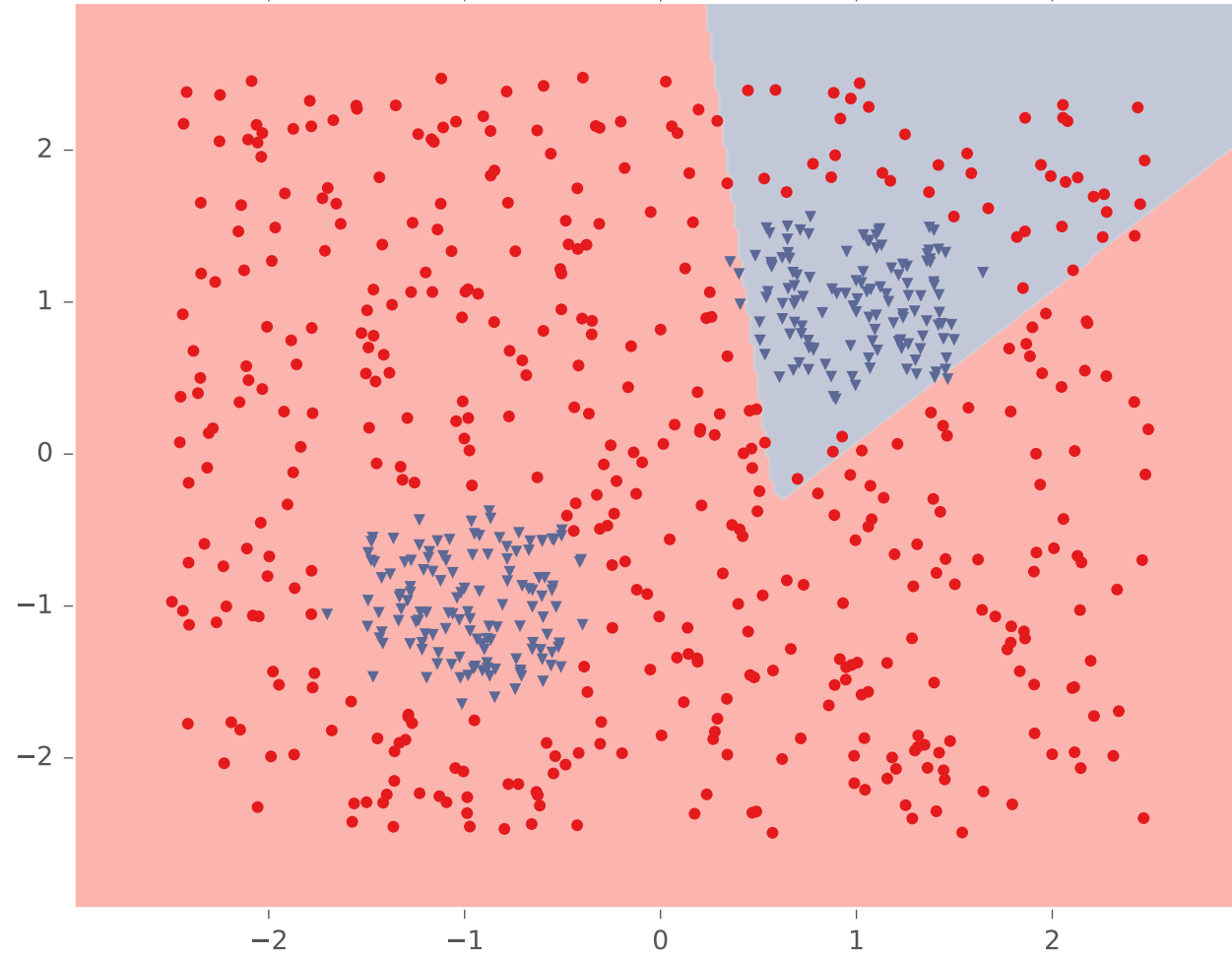

Example #4: Two Pockets

Tuned Neural Network (hidden=3, activation=logistic)

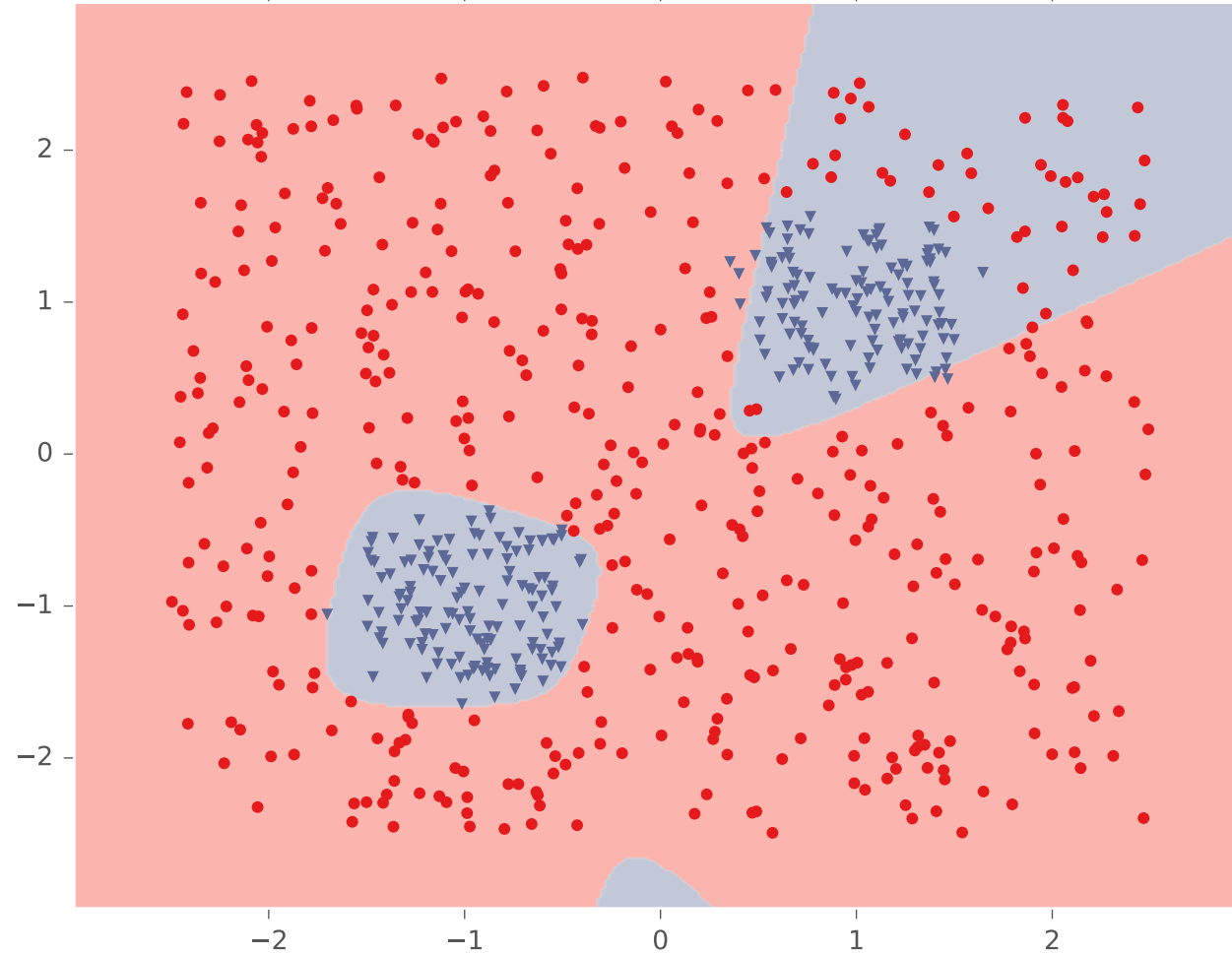

Example #4: Two Pockets

Tuned Neural Network (hidden=4, activation=logistic)

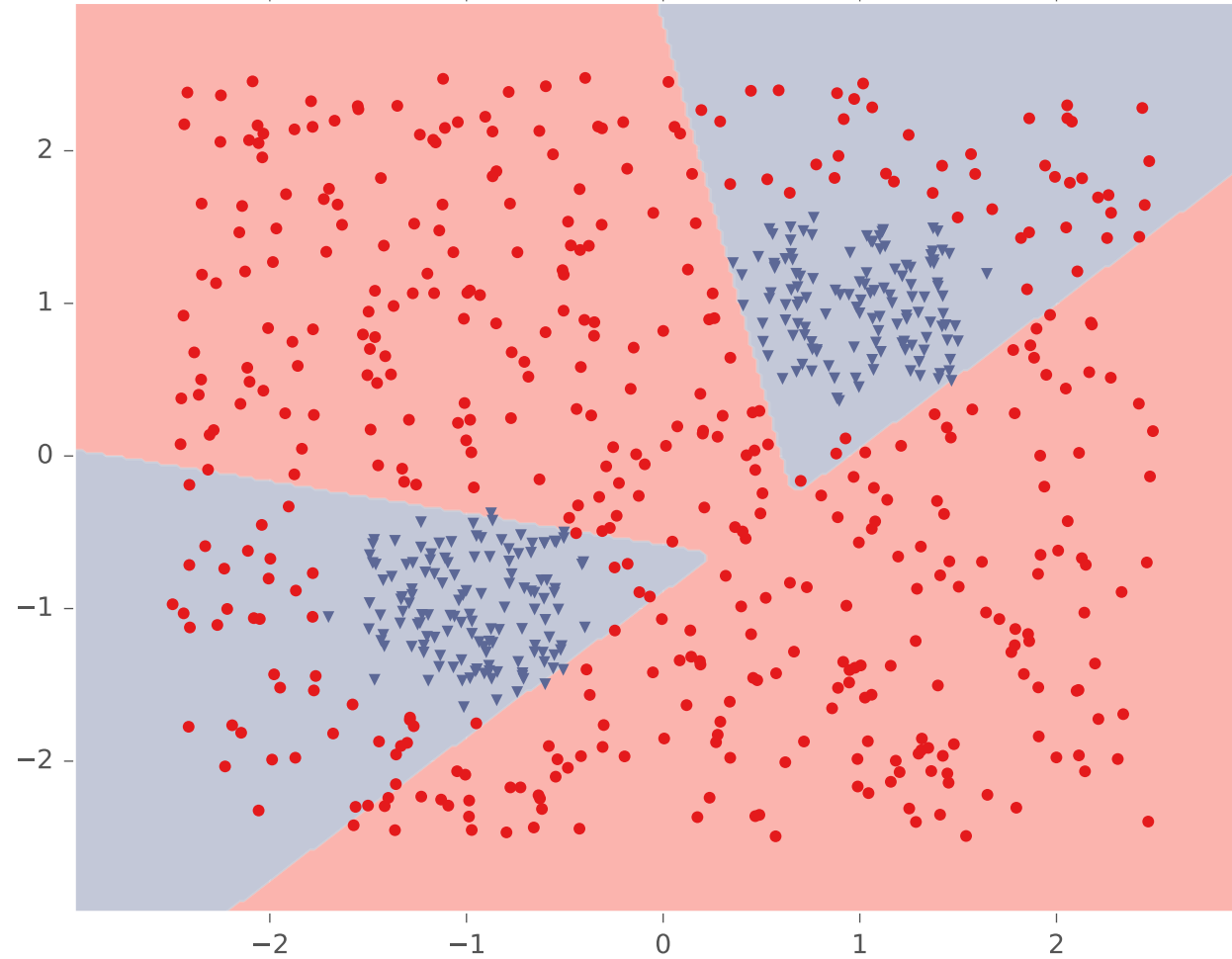

NW obj, f_{NL}
is non convex

Example #4: Two Pockets

Tuned Neural Network (hidden=10, activation=logistic)

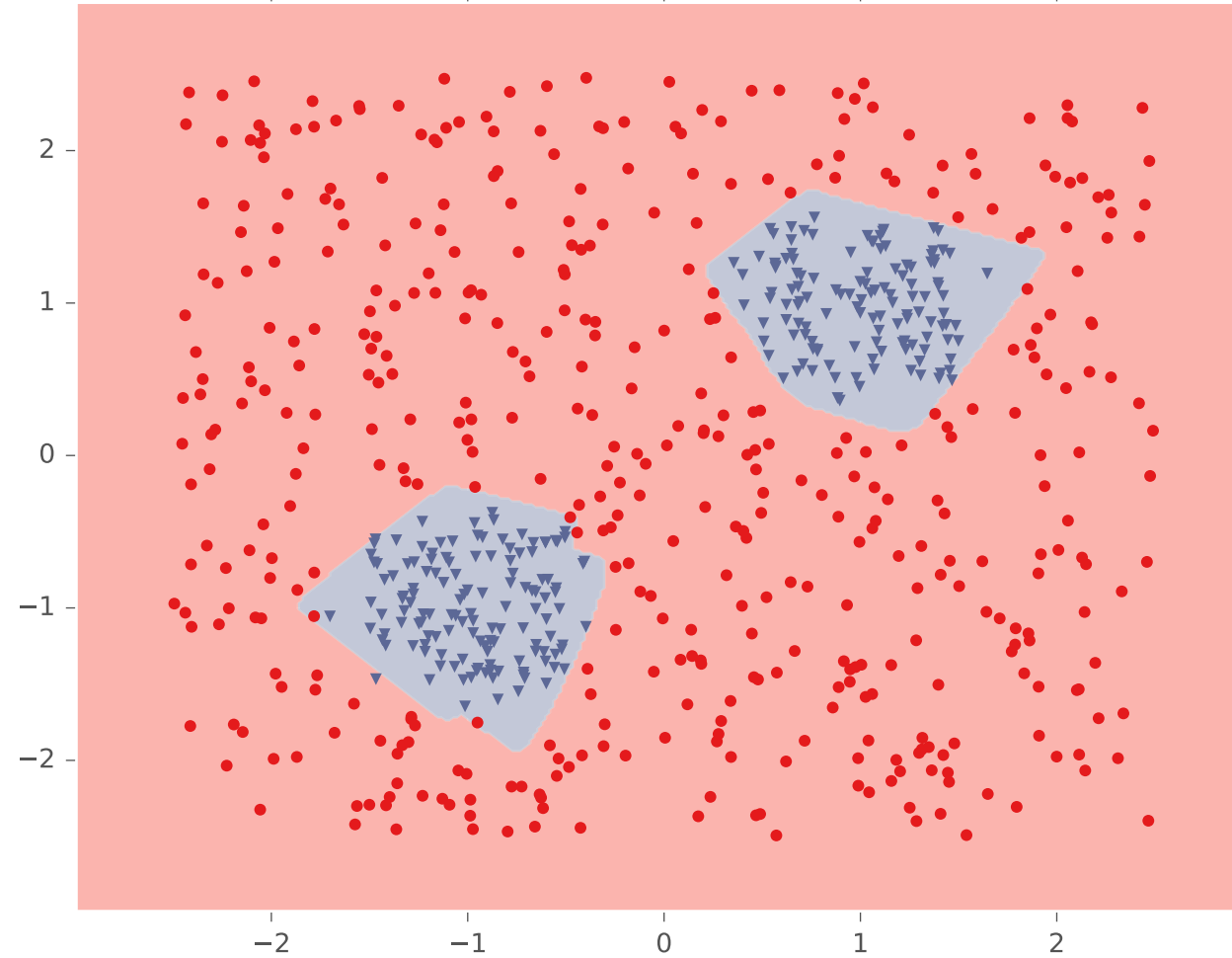

BUILDING DEEPER NETWORKS

Neural Network

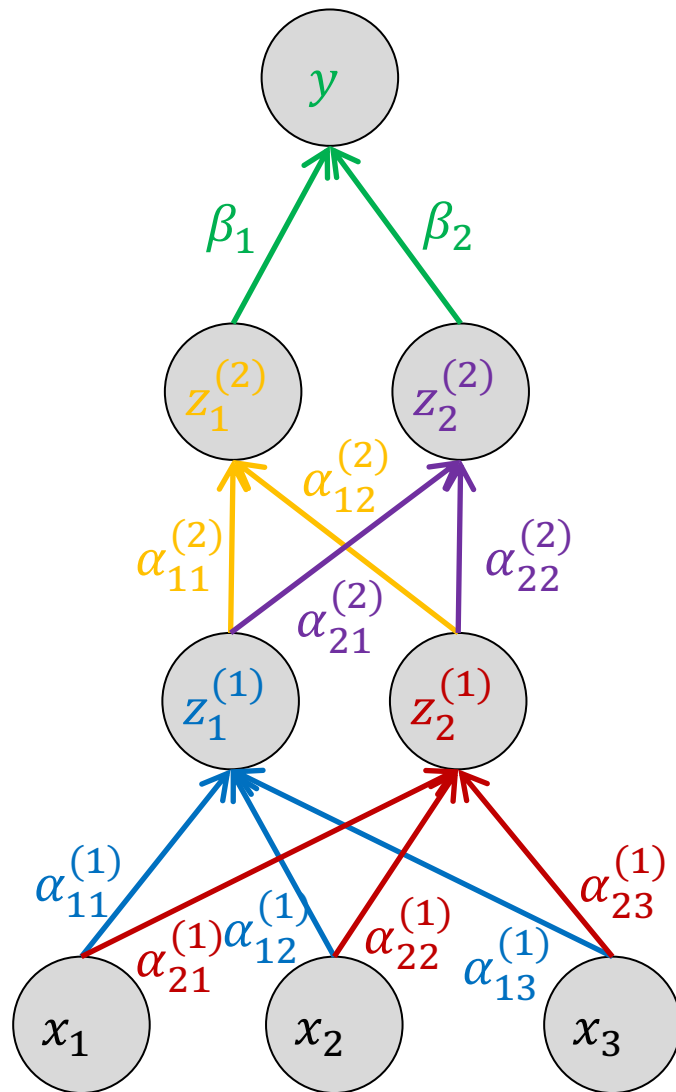

Example: Neural Network with 2 Hidden Layers and 2 Hidden Units

$$z_1^{(1)} = \sigma(\alpha_{11}^{(1)}x_1 + \alpha_{12}^{(1)}x_2 + \alpha_{13}^{(1)}x_3 + \alpha_{10}^{(1)})$$

$$z_2^{(1)} = \sigma(\alpha_{21}^{(1)}x_1 + \alpha_{22}^{(1)}x_2 + \alpha_{23}^{(1)}x_3 + \alpha_{20}^{(1)})$$

$$z_1^{(2)} = \sigma(\alpha_{11}^{(2)}z_1^{(1)} + \alpha_{12}^{(2)}z_2^{(1)} + \alpha_{10}^{(2)})$$

$$z_2^{(2)} = \sigma(\alpha_{21}^{(2)}z_1^{(1)} + \alpha_{22}^{(2)}z_2^{(1)} + \alpha_{20}^{(2)})$$

$$y = \sigma(\beta_1 z_1^{(2)} + \beta_2 z_2^{(2)} + \beta_0)$$

Neural Network (Matrix Form)

Example: Arbitrary Feed-forward Neural Network

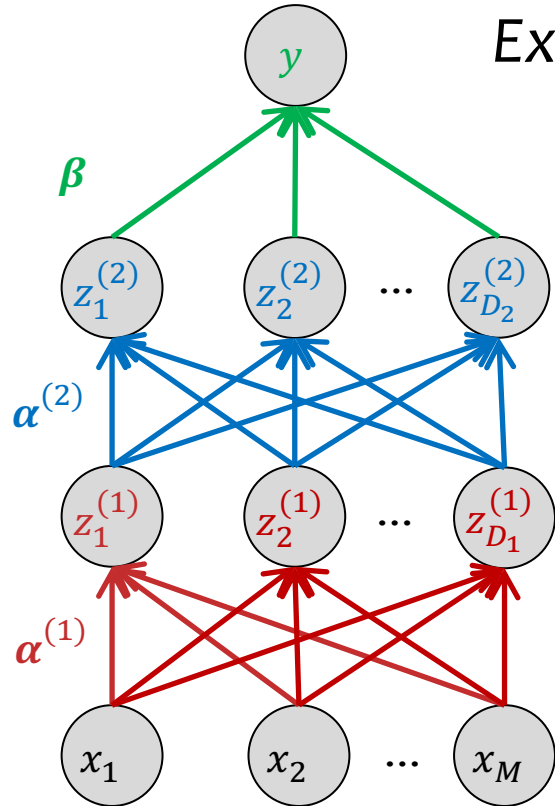

$$\beta \in \mathbb{R}^{D_2}$$

$$\beta_0 \in \mathbb{R}$$

$$\alpha^{(2)} \in \mathbb{R}^{D_1 \times D_2}$$

$$\mathbf{b}^{(2)} \in \mathbb{R}^{D_2}$$

$$\alpha^{(1)} \in \mathbb{R}^{M \times D_1}$$

$$\mathbf{b}^{(1)} \in \mathbb{R}^{D_1}$$

$$y = \sigma((\beta)^T \mathbf{z}^{(2)} + \beta_0)$$

$$\mathbf{z}^{(2)} = \sigma((\alpha^{(2)})^T \mathbf{z}^{(1)} + \mathbf{b}^{(2)})$$

$$\mathbf{z}^{(1)} = \sigma((\alpha^{(1)})^T \mathbf{x} + \mathbf{b}^{(1)})$$

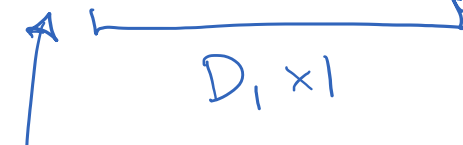

applied elementwise

$$\sigma : \mathbb{R} \rightarrow \mathbb{R}$$

$$\vec{a} = \sigma(\vec{c})$$

$$\Rightarrow a_i = \sigma(c_i)$$

Neural Network (Vector Form)

Neural Network with 1 Hidden Layers
and 2 Hidden Units (Matrix Form)

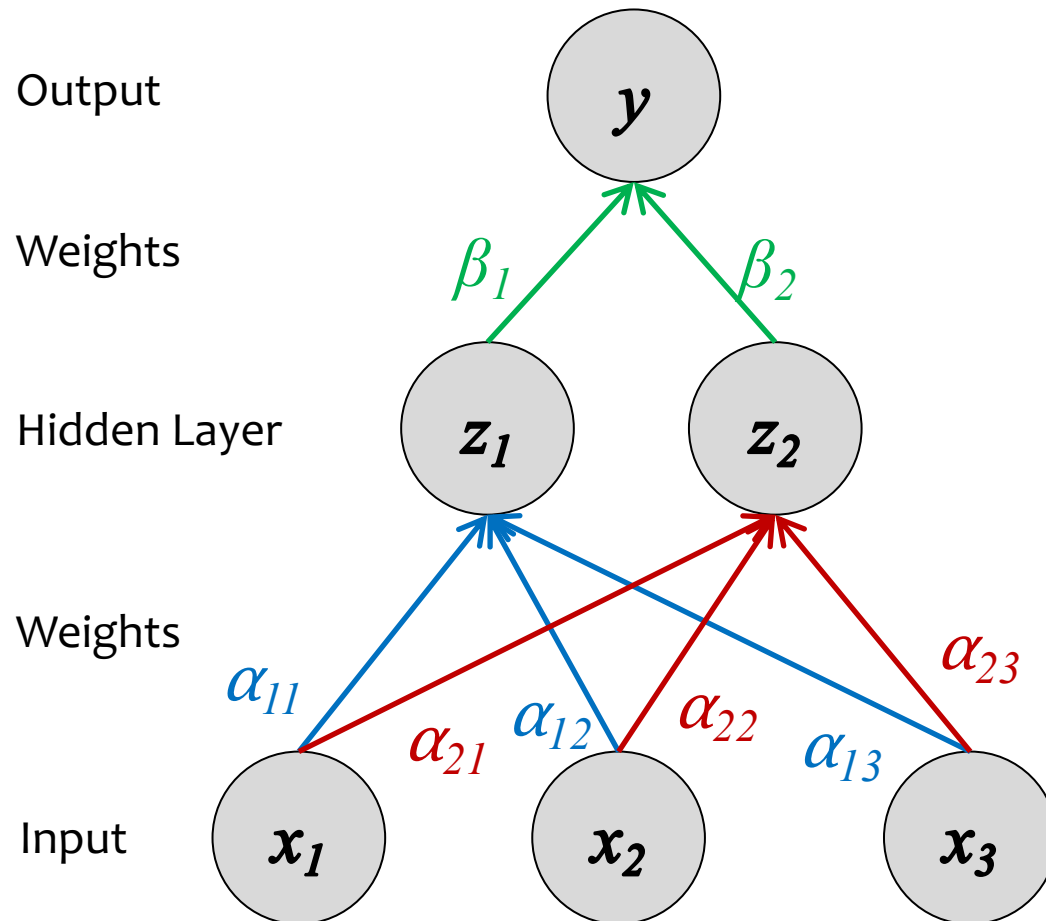

$$y = \sigma(\beta^T \mathbf{z})$$

$$z_2 = \sigma(\alpha_{2, \cdot}^T \mathbf{x})$$

$$z_1 = \sigma(\alpha_{1, \cdot}^T \mathbf{x})$$

Deeper Networks

Q: How many layers should we use?

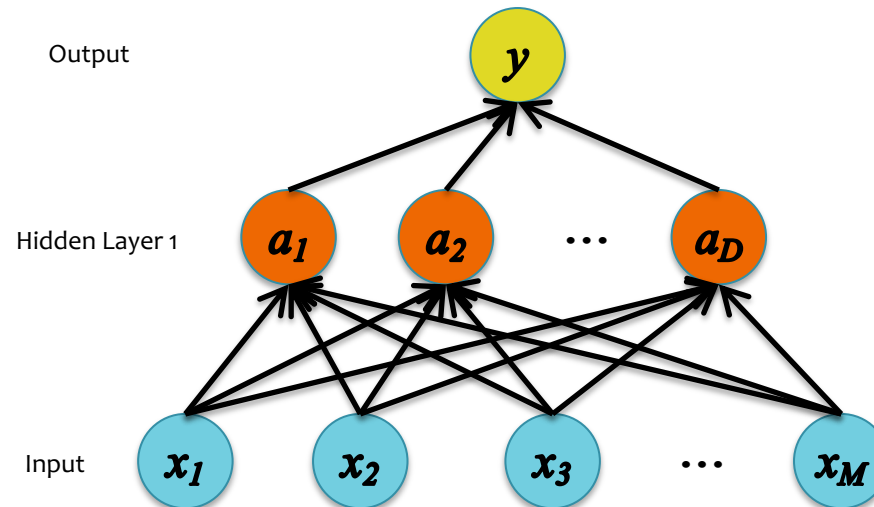

Deeper Networks

Q: How many layers should we use?

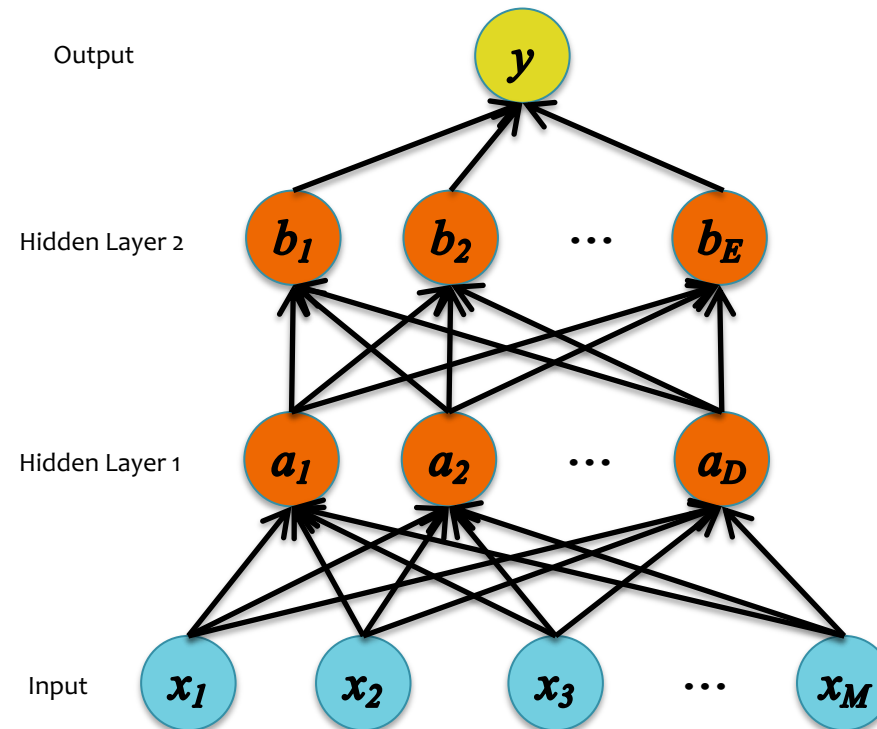

Deeper Networks

Q: *How many layers should we use?*

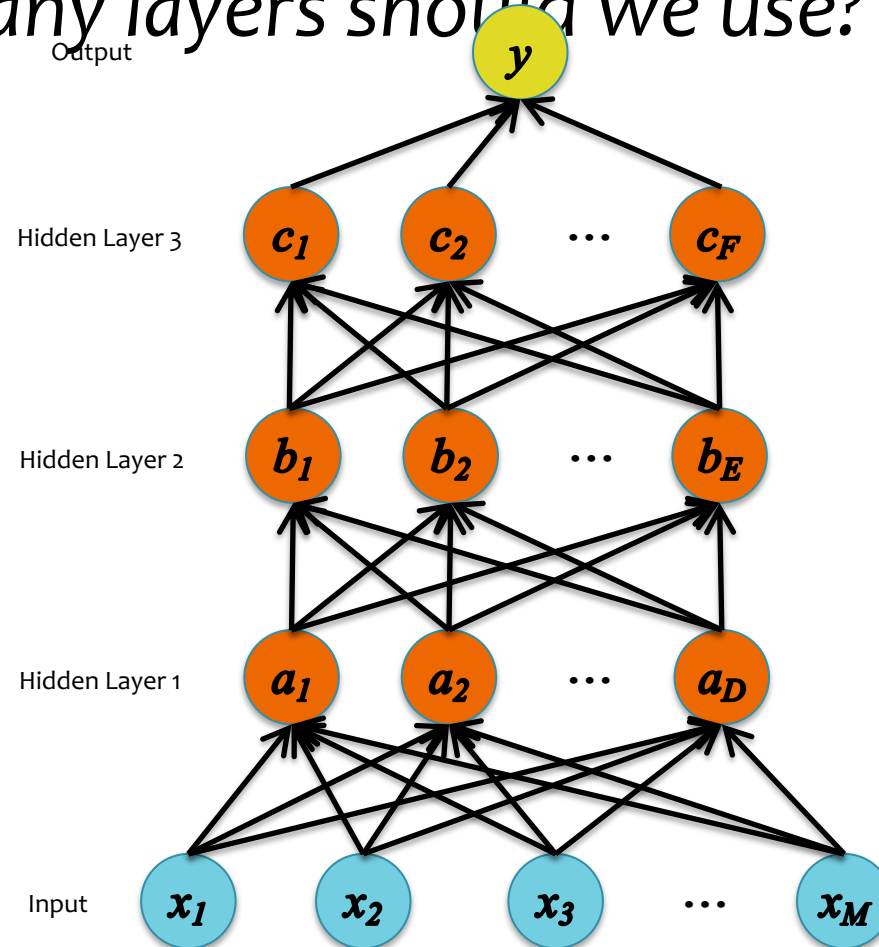

Deeper Networks

Q: How many layers should we use?

- **Theoretical answer:**

- A neural network with 1 hidden layer is a **universal function approximator**
- Cybenko (1989): For any continuous function $g(\mathbf{x})$, there exists a 1-hidden-layer neural net $h_{\theta}(\mathbf{x})$ s.t. $|h_{\theta}(\mathbf{x}) - g(\mathbf{x})| < \epsilon$ for all \mathbf{x} , assuming sigmoid activation functions

- **Empirical answer:**

- Before 2006: “Deep networks (e.g. 3 or more hidden layers) are too hard to train”
- After 2006: “Deep networks are easier to train than shallow networks (e.g. 2 or fewer layers) for many problems”

Big caveat: You need to know and use the right tricks.

Feature Learning

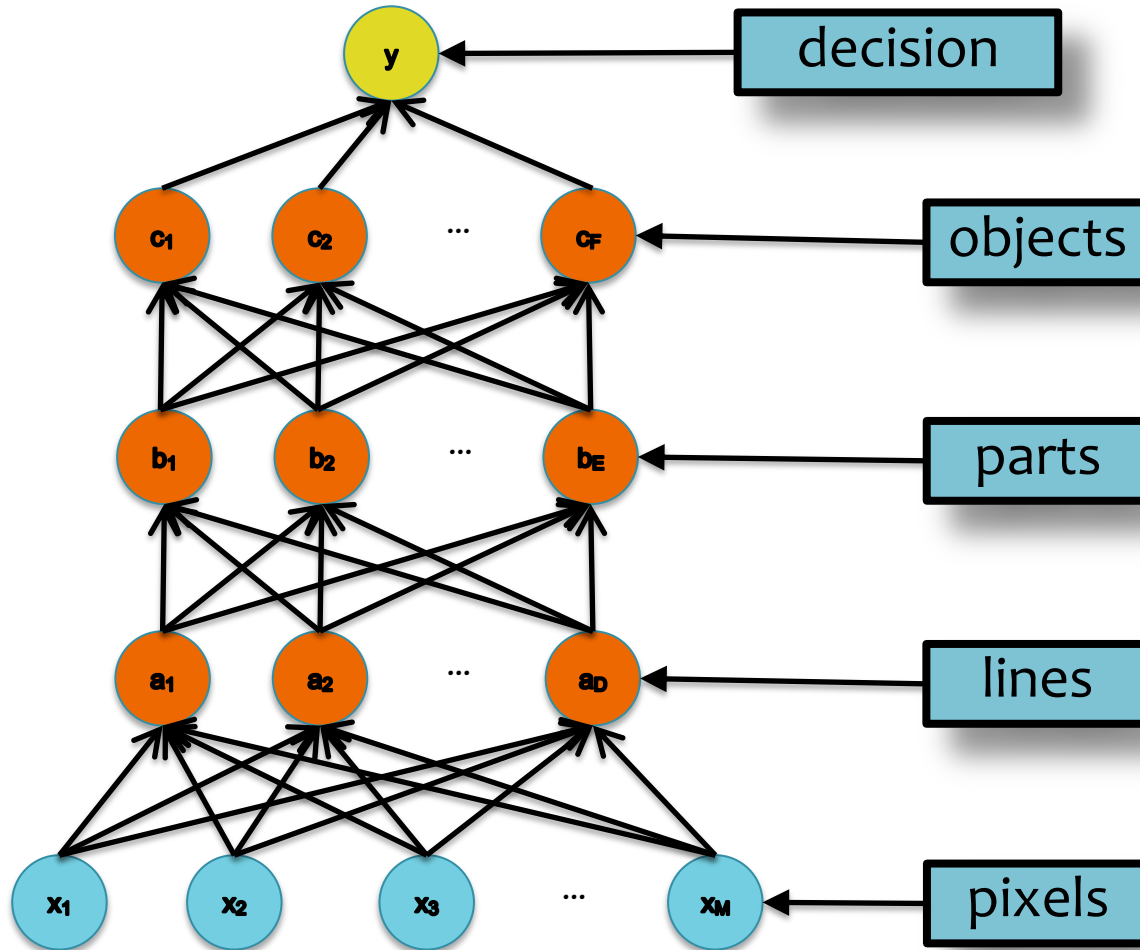

- **Traditional feature engineering:** build up levels of abstraction by hand
- **Deep networks** (e.g. convolution networks): learn the increasingly higher levels of abstraction from data
 - each layer is a learned feature representation
 - sophistication increases in higher layers

Feature Learning

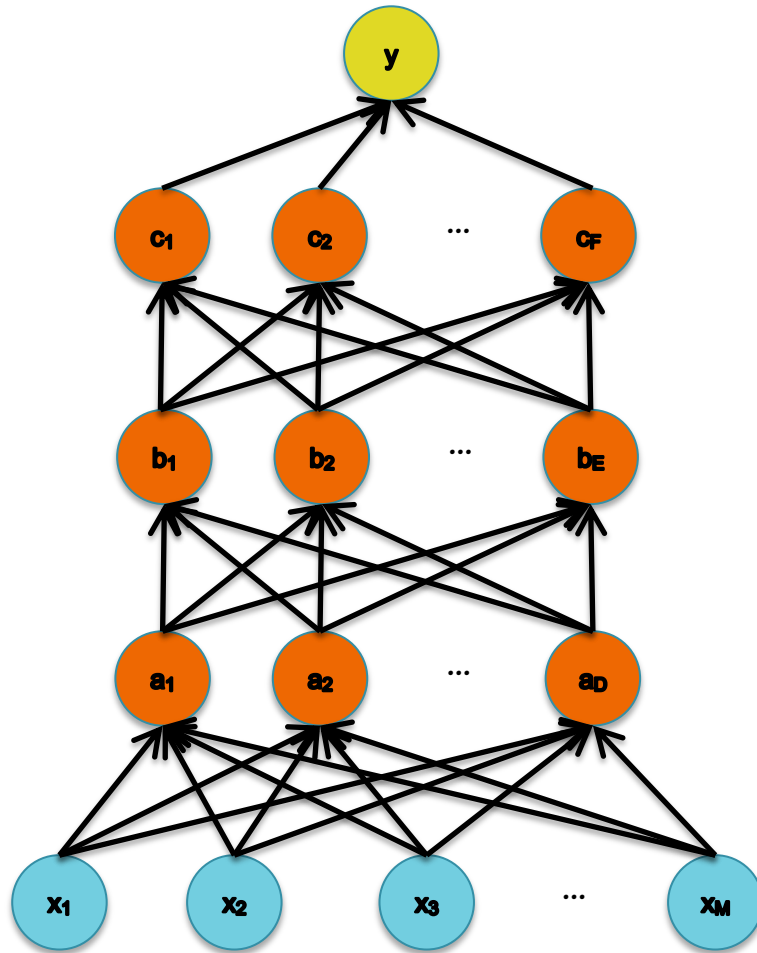

CBDN on Faces

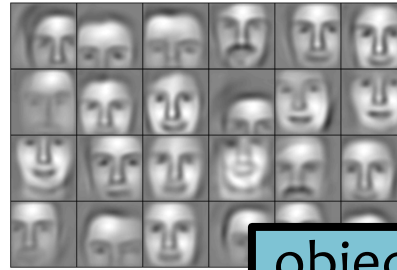

objects

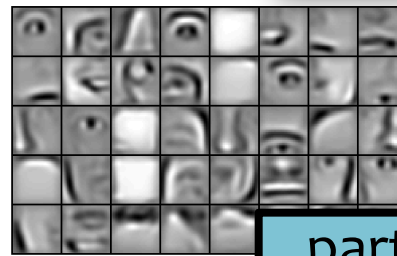

parts



lines

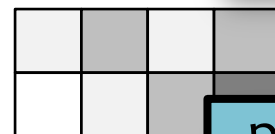

pixels

- **Traditional feature engineering:** build up levels of abstraction by hand
- **Deep networks** (e.g. convolution networks): learn the increasingly higher levels of abstraction from data
 - each layer is a learned feature representation
 - sophistication increases in higher layers

Feature Learning

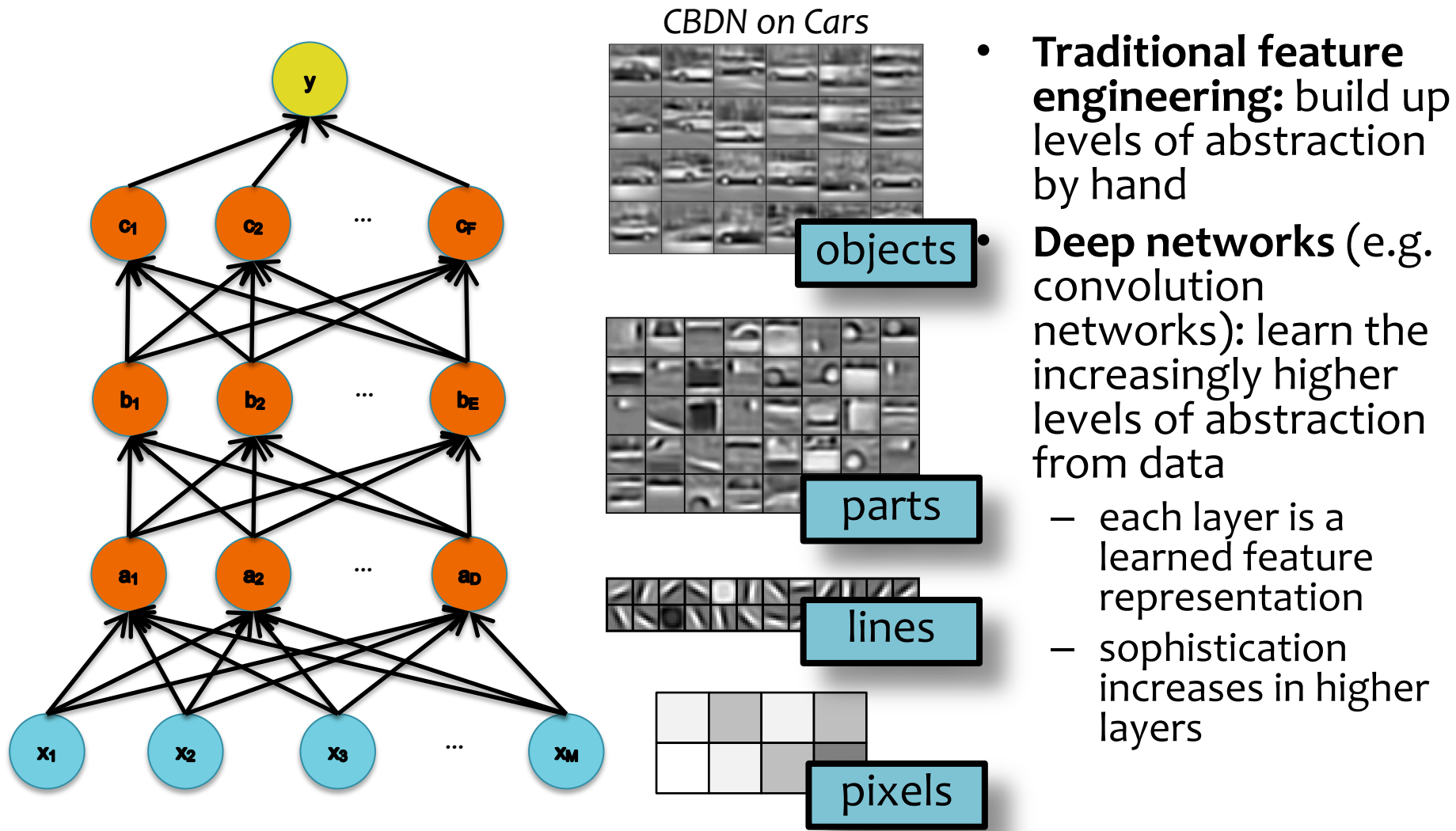

Figures from Lee et al. (ICML 2009)

Neural Network Errors

Poll Question 2: For which of the datasets below does there exist a one-hidden layer neural network that achieves zero classification error? **Select all that apply.**

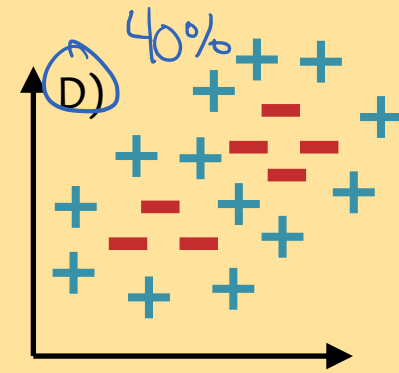
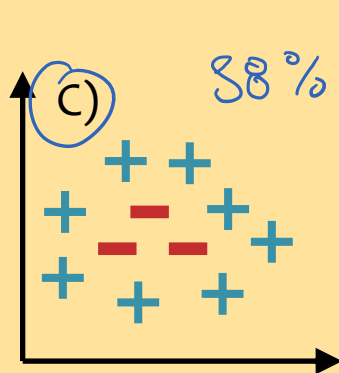
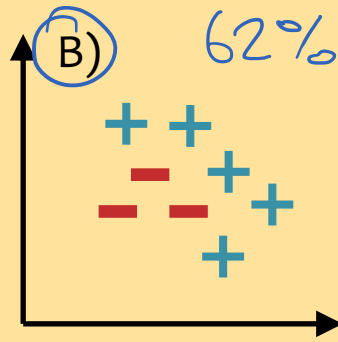
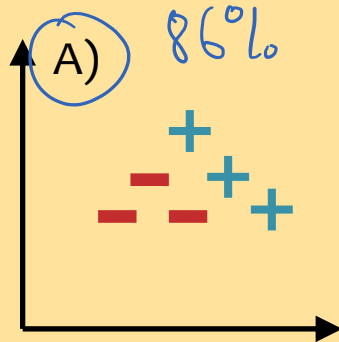

$E = \text{toxic}$

Poll Question 3: For which of the datasets below does there exist a one-hidden layer neural network for regression that achieves nearly zero MSE? **Select all that apply.**

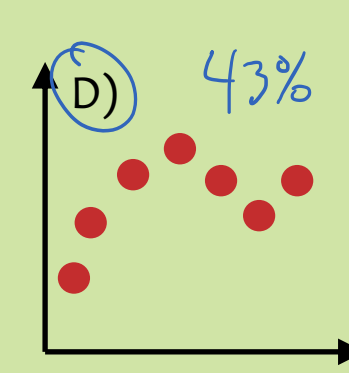
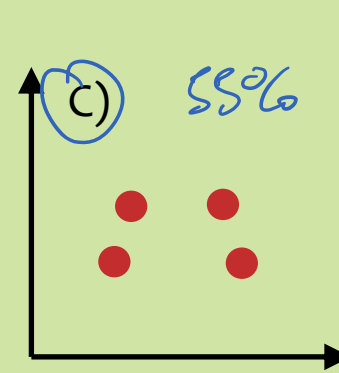
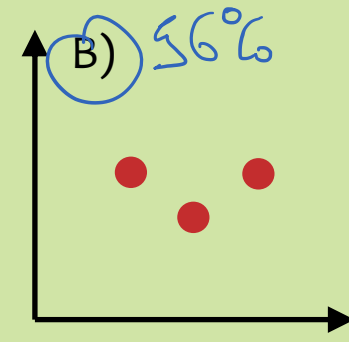
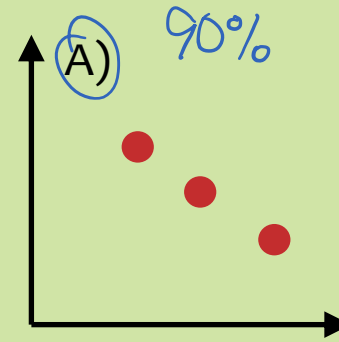

$E = \text{toxic}$

Neural Network Architectures

Even for a basic Neural Network, there are many design decisions to make:

1. # of hidden layers (depth)
2. # of units per hidden layer (width)
3. Type of activation function (nonlinearity)
4. Form of objective function
5. How to initialize the parameters

ACTIVATION FUNCTIONS

Activation Functions

Neural Network with sigmoid activation functions

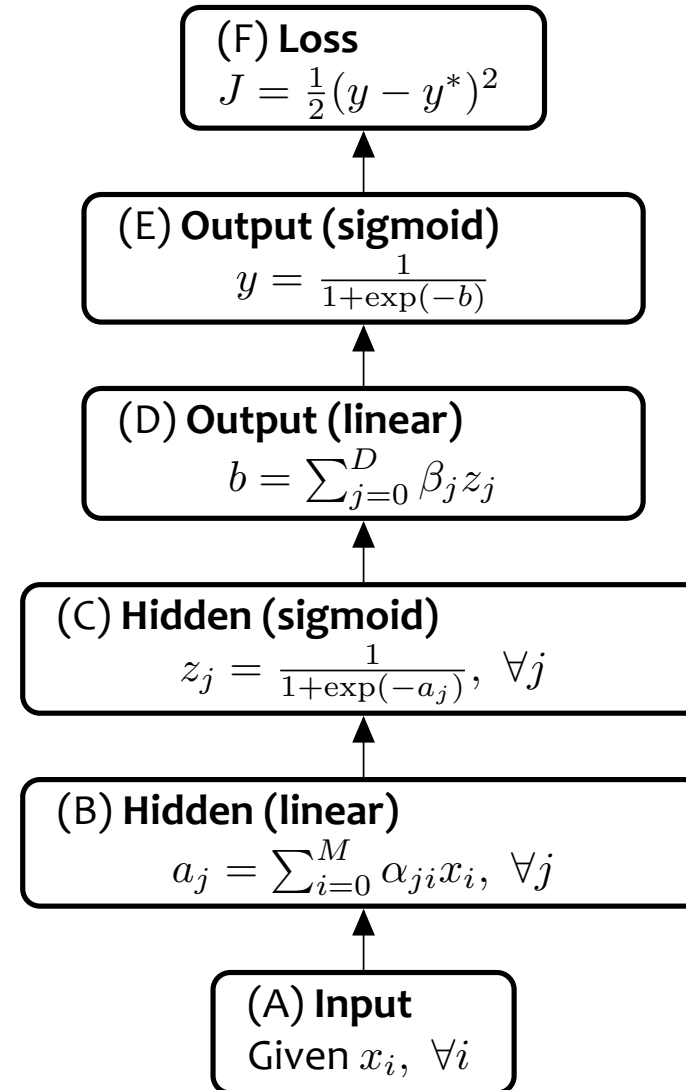
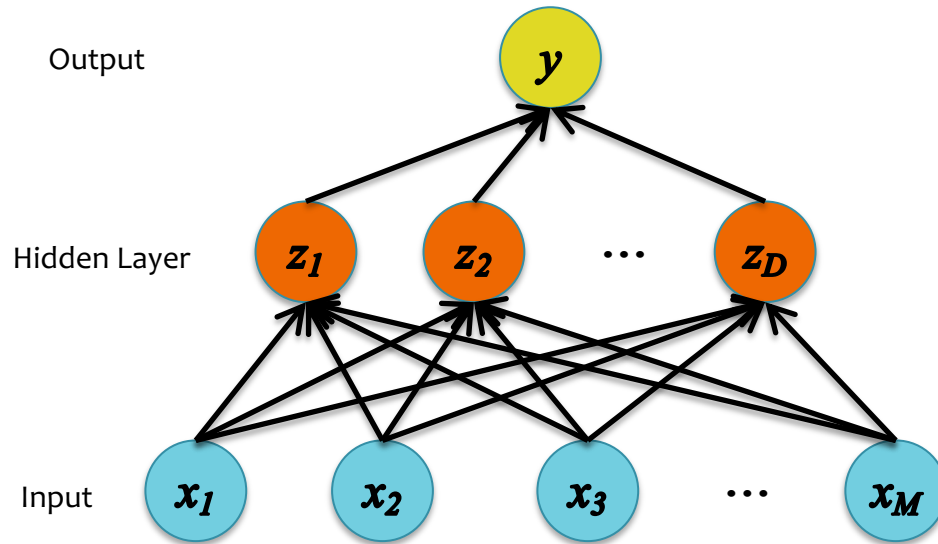

Activation Functions

Neural Network with arbitrary nonlinear activation functions

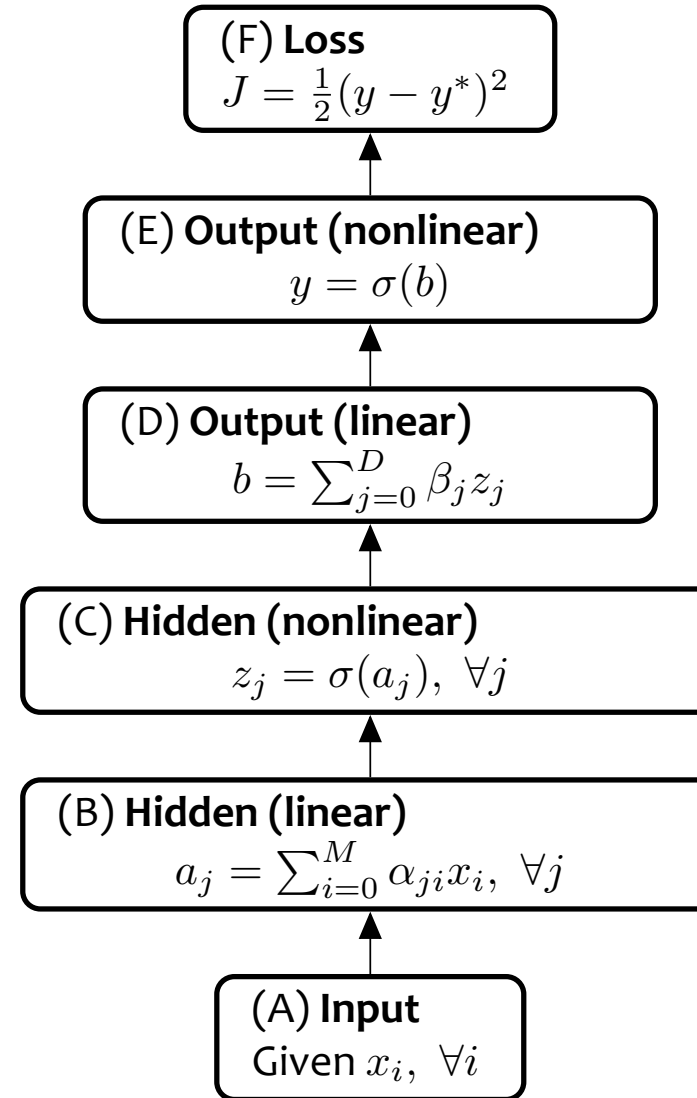
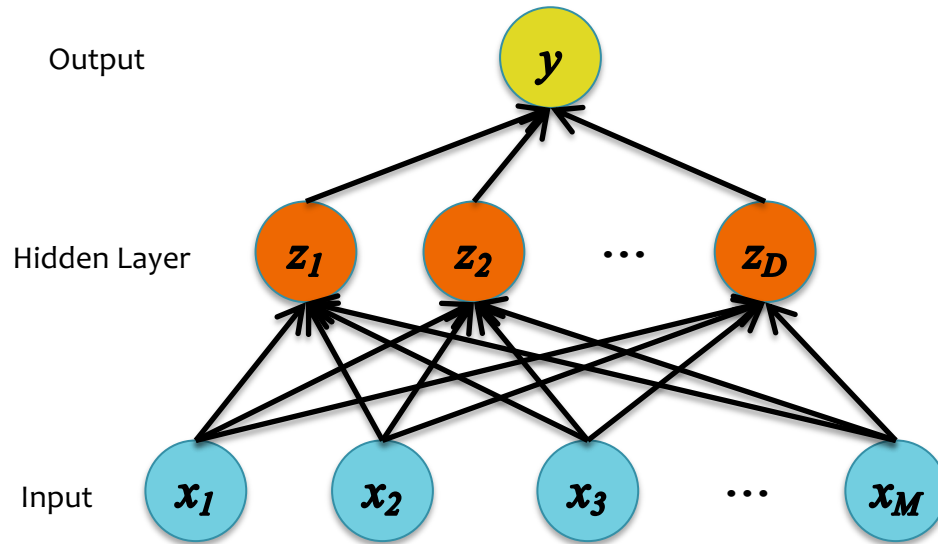

Activation Functions

So far, we've assumed that the activation function (nonlinearity) is always the sigmoid function...

...but the sigmoid is not widely used in modern neural networks

Sigmoid (aka. logistic) function

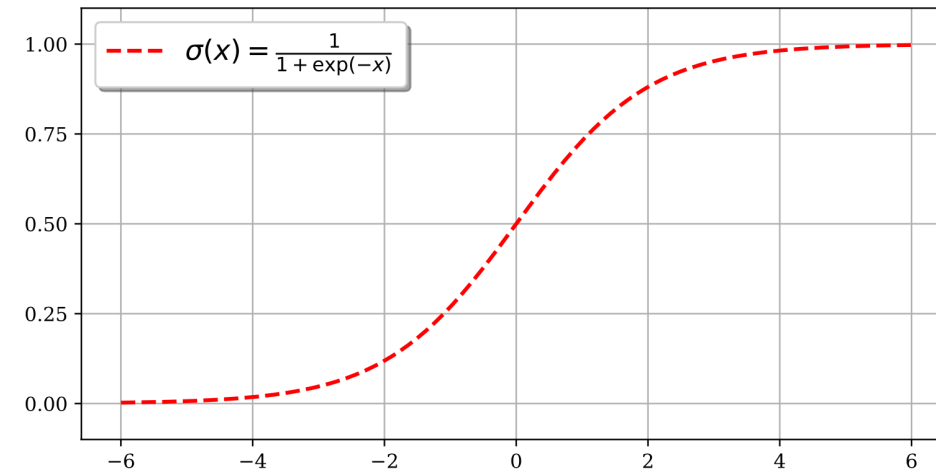

Hyperbolic tangent function

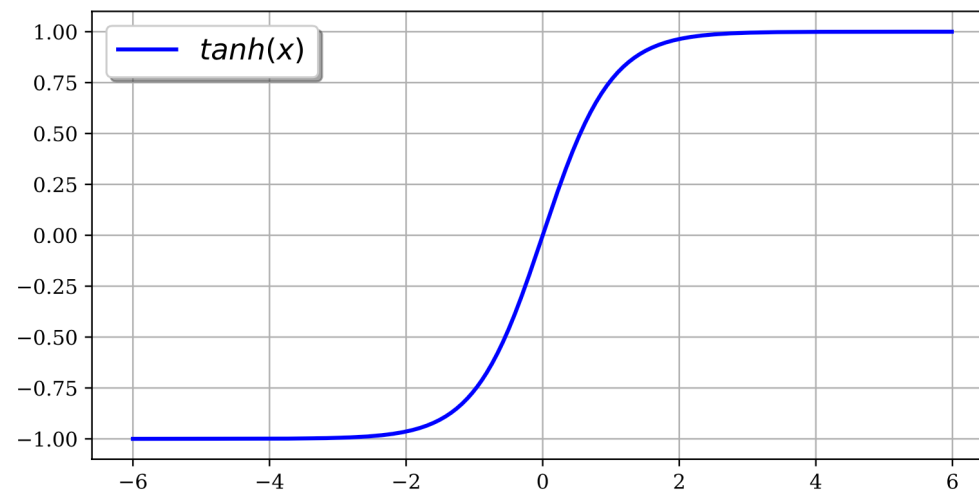

Activation Functions

- sigmoid, $\sigma(x)$
 - output in range (0,1)
 - good for probabilistic outputs
- hyperbolic tangent, $\tanh(x)$
 - similar shape to sigmoid, but output in range (-1,+1)

Sigmoid (aka. logistic) function

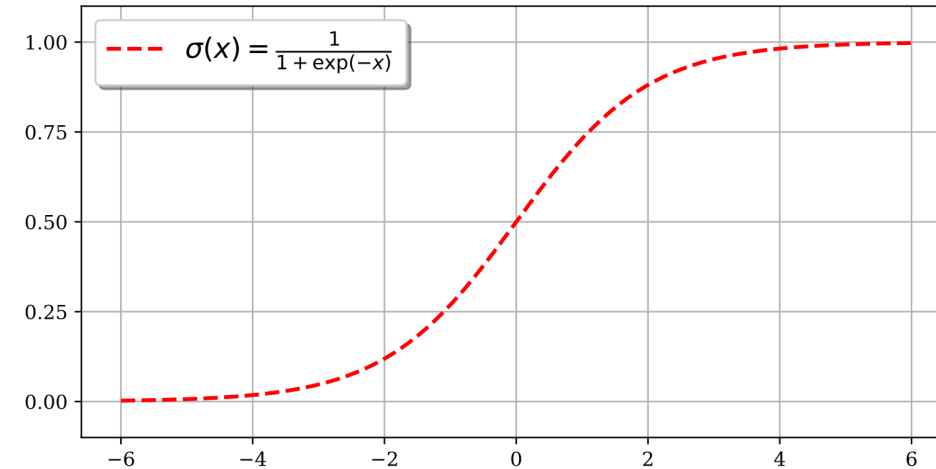

Hyperbolic tangent function

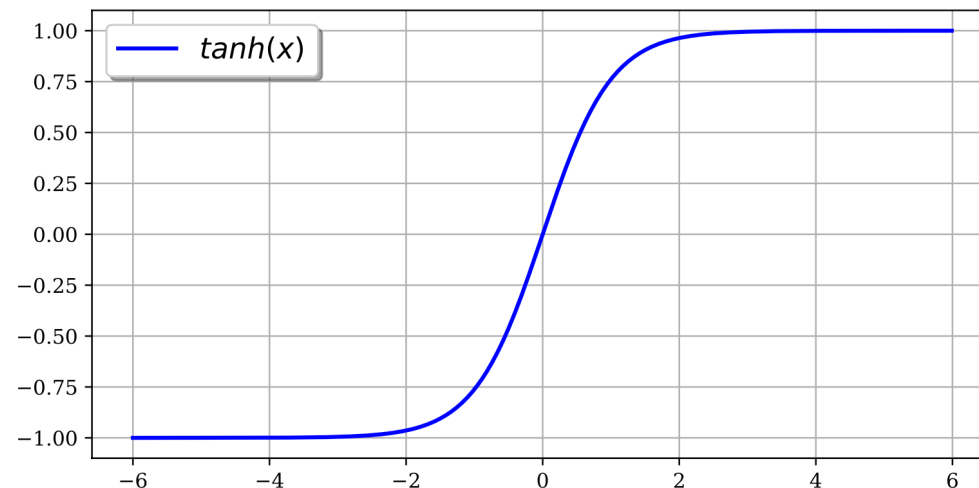

Understanding the difficulty of training deep feedforward neural networks

AI Stats 2010

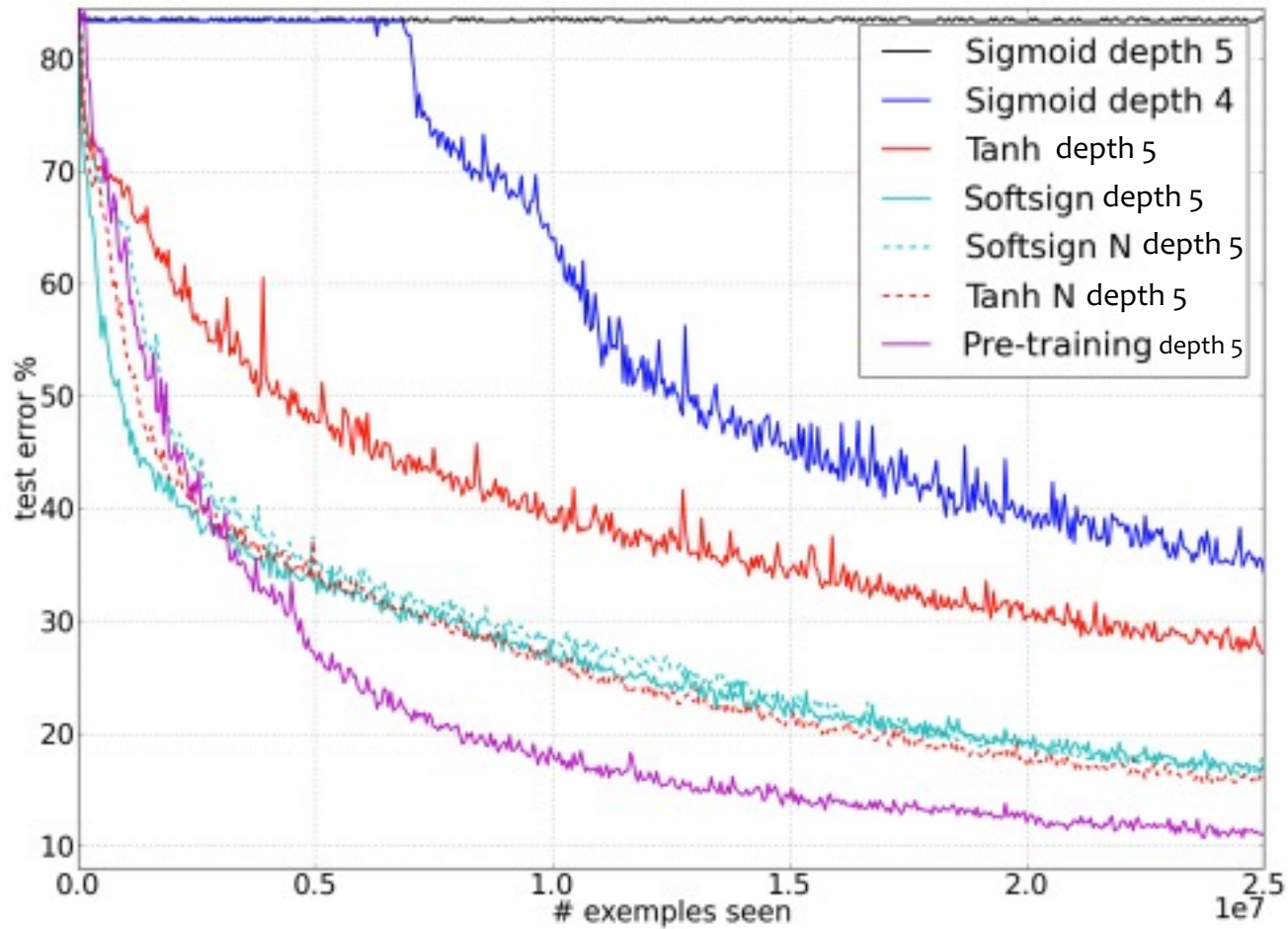

} sigmoid
vs.
tanh

Figure from Glorot & Benthio (2010)

Activation Functions

- Rectified Linear Unit (ReLU)
 - avoids the vanishing gradient problem
 - derivative is fast to compute

$$\text{ReLU}(x) = \max(0, x)$$

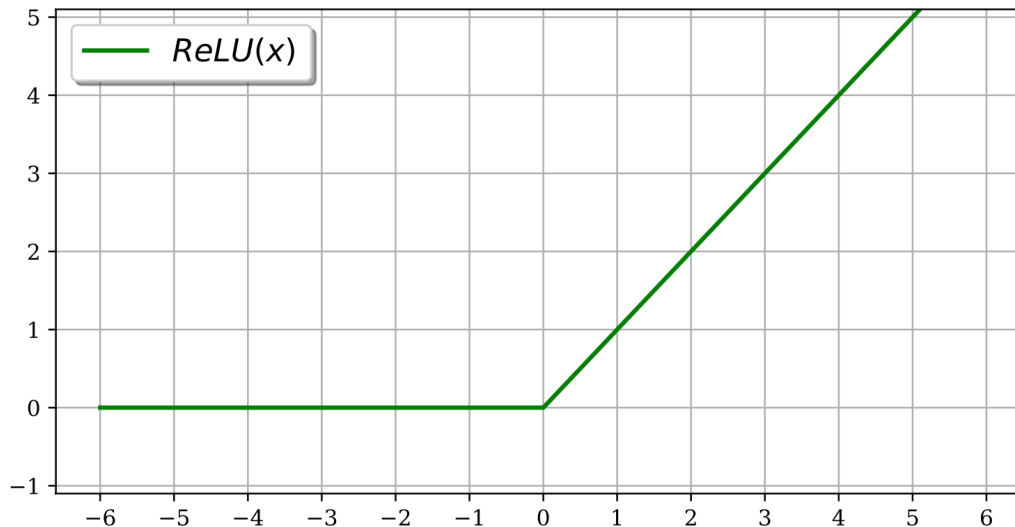

Activation Functions

- Rectified Linear Unit (ReLU)

- avoids the vanishing gradient problem
- derivative is fast to compute

$$\text{ReLU}(x) = \max(0, x)$$

- Exponential Linear Unit (ELU)

- same as ReLU on positive inputs
- unlike ReLU, allows negative outputs and smoothly transitions for $x < 0$

$$\text{ELU}(x) = \begin{cases} x, & \text{if } x > 0 \\ \alpha(\exp(x) - 1), & \text{if } x \leq 0 \end{cases}$$

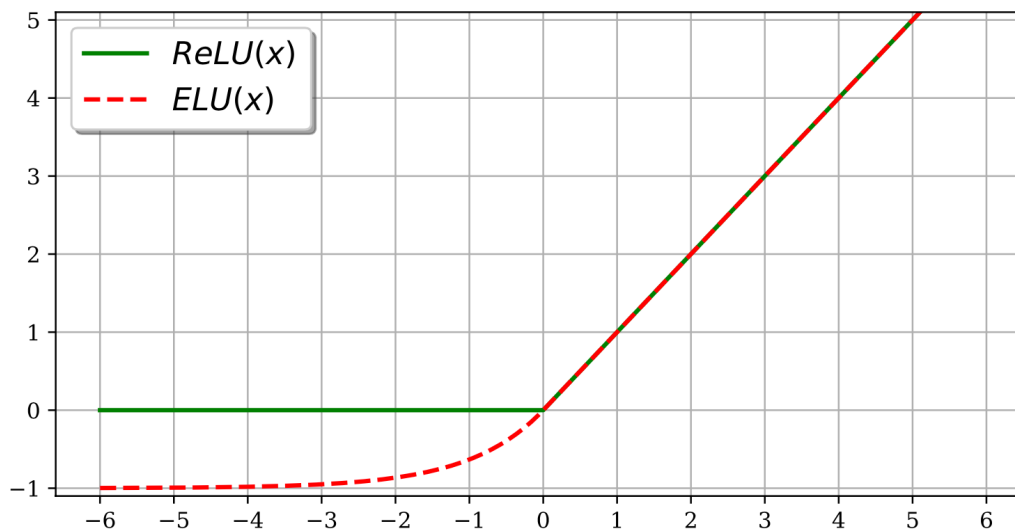

Activation Functions

Image Classification Benchmark (CIFAR-10)

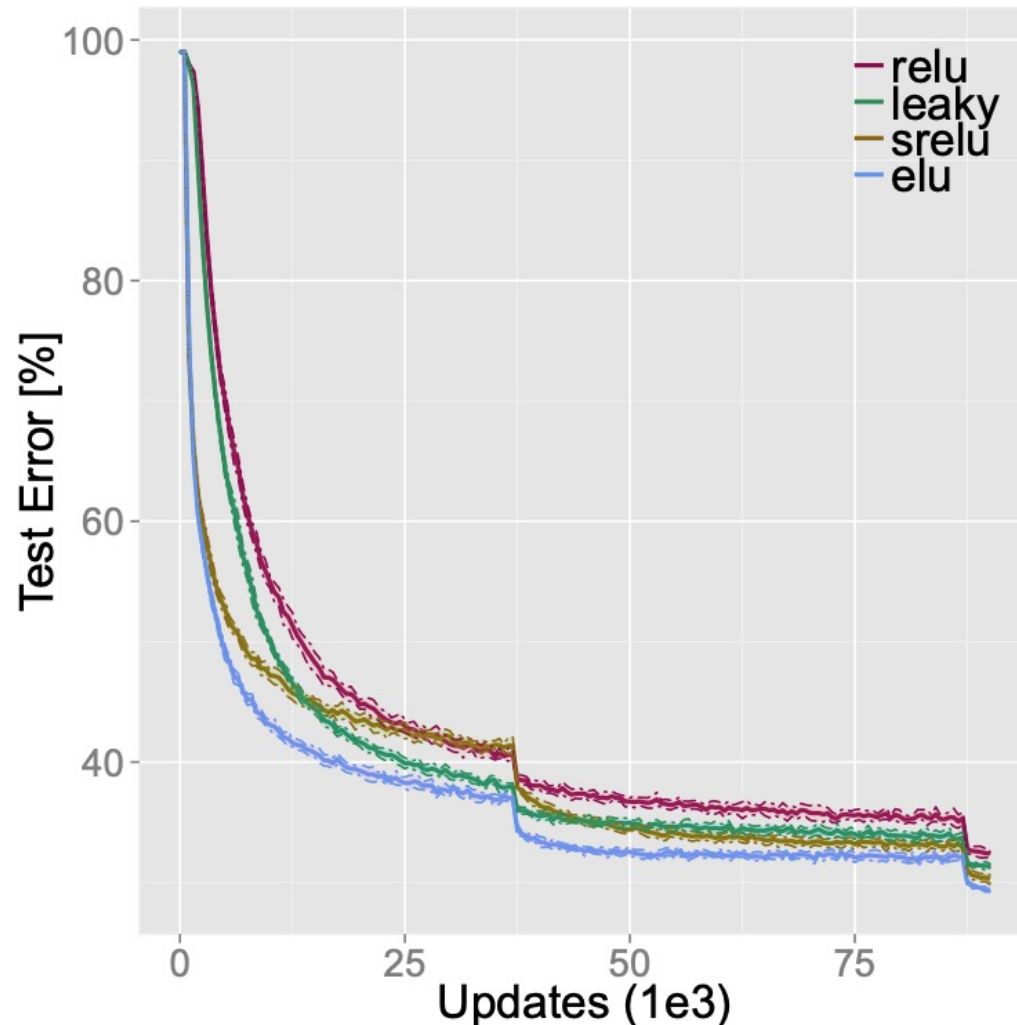

1. Training loss converges fastest with ELU
2. ELU(x) yields lower test error than ReLU(x) on CIFAR-10

Figure from Clevert et al. (2016)

Neural Networks Objectives

You should be able to...

- Explain the biological motivations for a neural network
- Combine simpler models (e.g. linear regression, binary logistic regression, multinomial logistic regression) as components to build up feed-forward neural network architectures
- Explain the reasons why a neural network can model nonlinear decision boundaries for classification
- Compare and contrast feature engineering with learning features
- Identify (some of) the options available when designing the architecture of a neural network
- Implement a feed-forward neural network