



Probabilistic Graphical Models

Representation of undirected GM

Eric Xing

Lecture 3, January 20, 2016

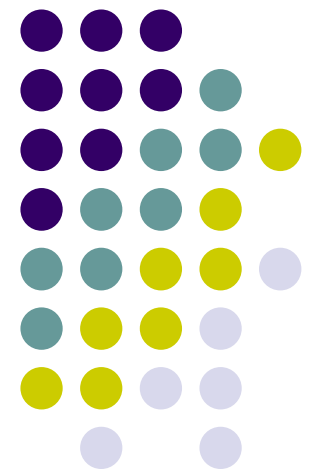
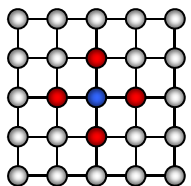

Reading: KF-chap4



Two types of GMs

- **Directed edges** give **causality** relationships (Bayesian Network or Directed Graphical Model):

$$\begin{aligned}
 & P(X_1, X_2, X_3, X_4, X_5, X_6, X_7, X_8) \\
 &= P(X_1) P(X_2) P(X_3/X_1) P(X_4/X_2) P(X_5/X_2) \\
 & \quad P(X_6/X_3, X_4) P(X_7/X_6) P(X_8/X_5, X_6)
 \end{aligned}$$

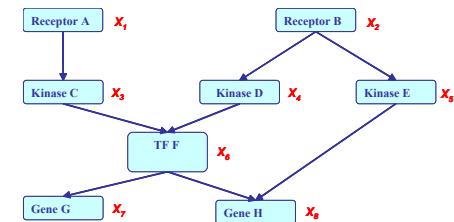

- **Undirected edges** simply give **correlations** between variables (Markov Random Field or Undirected Graphical model):

$$\begin{aligned}
 & P(X_1, X_2, X_3, X_4, X_5, X_6, X_7, X_8) \\
 &= \frac{1}{Z} \exp\{E(X_1)+E(X_2)+E(X_3, X_1)+E(X_4, X_2)+E(X_5, X_2) \\
 & \quad + E(X_6, X_3, X_4)+E(X_7, X_6)+E(X_8, X_5, X_6)\}
 \end{aligned}$$

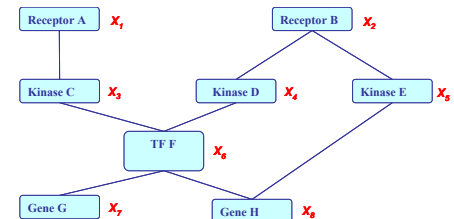

Review: independence properties of DAGs

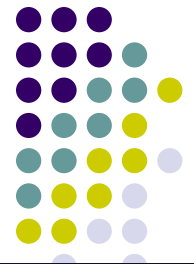

- Defn: let $I_l(\mathcal{G})$ be the set of local independence properties encoded by DAG \mathcal{G} , namely:

$$I(\mathcal{G}) = \{X \perp Z | Y : \text{dsep}_{\mathcal{G}}(X; Z | Y)\}$$

- Defn: A DAG \mathcal{G} is an **I-map** (independence-map) of P if $I_l(\mathcal{G}) \subseteq I(P)$
- A fully connected DAG \mathcal{G} is an I-map for any distribution, since $I_l(\mathcal{G}) = \emptyset \subseteq I(P)$ for any P .
- Defn: A DAG \mathcal{G} is a minimal I-map for P if it is an I-map for P , and if the removal of even a single edge from \mathcal{G} renders it not an I-map.
- A distribution may have several minimal I-maps
 - Each corresponding to a specific node-ordering



P-maps

- Defn: A DAG \mathcal{G} is a **perfect map** (P-map) for a distribution P if $I(P)=I(\mathcal{G})$.
- Thm: not every distribution has a perfect map as DAG.
 - Pf by counterexample. Suppose we have a model where $A \perp C \mid \{B,D\}$, and $B \perp D \mid \{A,C\}$.
This cannot be represented by any Bayes net.
 - e.g., BN1 wrongly says $B \perp D \mid A$, BN2 wrongly says $B \perp D$.

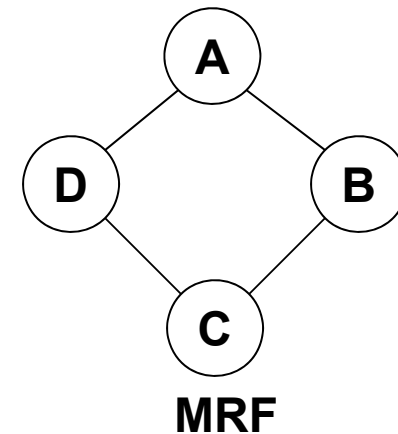
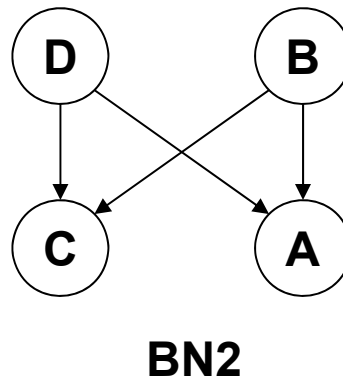
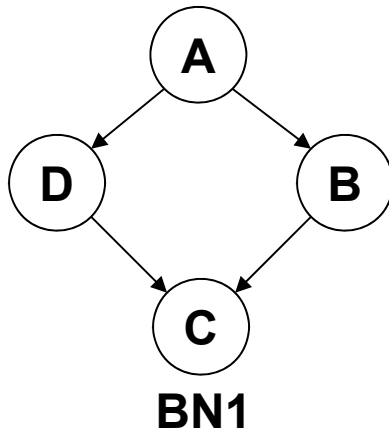



P-maps

- Defn: A DAG \mathcal{G} is a **perfect map** (P-map) for a distribution P if $I(P)=I(\mathcal{G})$.
- Thm: not every distribution has a perfect map as DAG.
 - Pf by counterexample. Suppose we have a model where $A \perp C \mid \{B,D\}$, and $B \perp D \mid \{A,C\}$.
This cannot be represented by any Bayes net.
 - e.g., BN1 wrongly says $B \perp D \mid A$, BN2 wrongly says $B \perp D$.
 - The fact that G is a minimal I-map for P is far from a guarantee that G captures the independence structure in P
 - The P-map of a distribution is **unique up to I-equivalence** between networks. That is, a distribution P can have many P-maps, but all of them are I-equivalent.

Undirected graphical models (UGM)

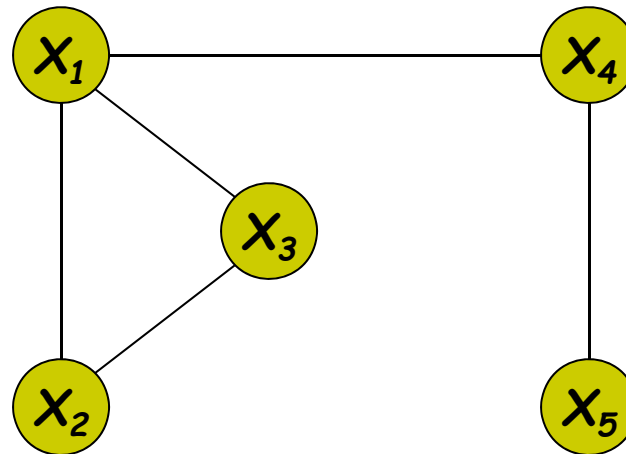

- Pairwise (non-causal) relationships
- Can write down model, and score specific configurations of the graph, but no explicit way to generate samples
- Contingency constrains on node configurations

A Canonical Example: understanding complex scene ...

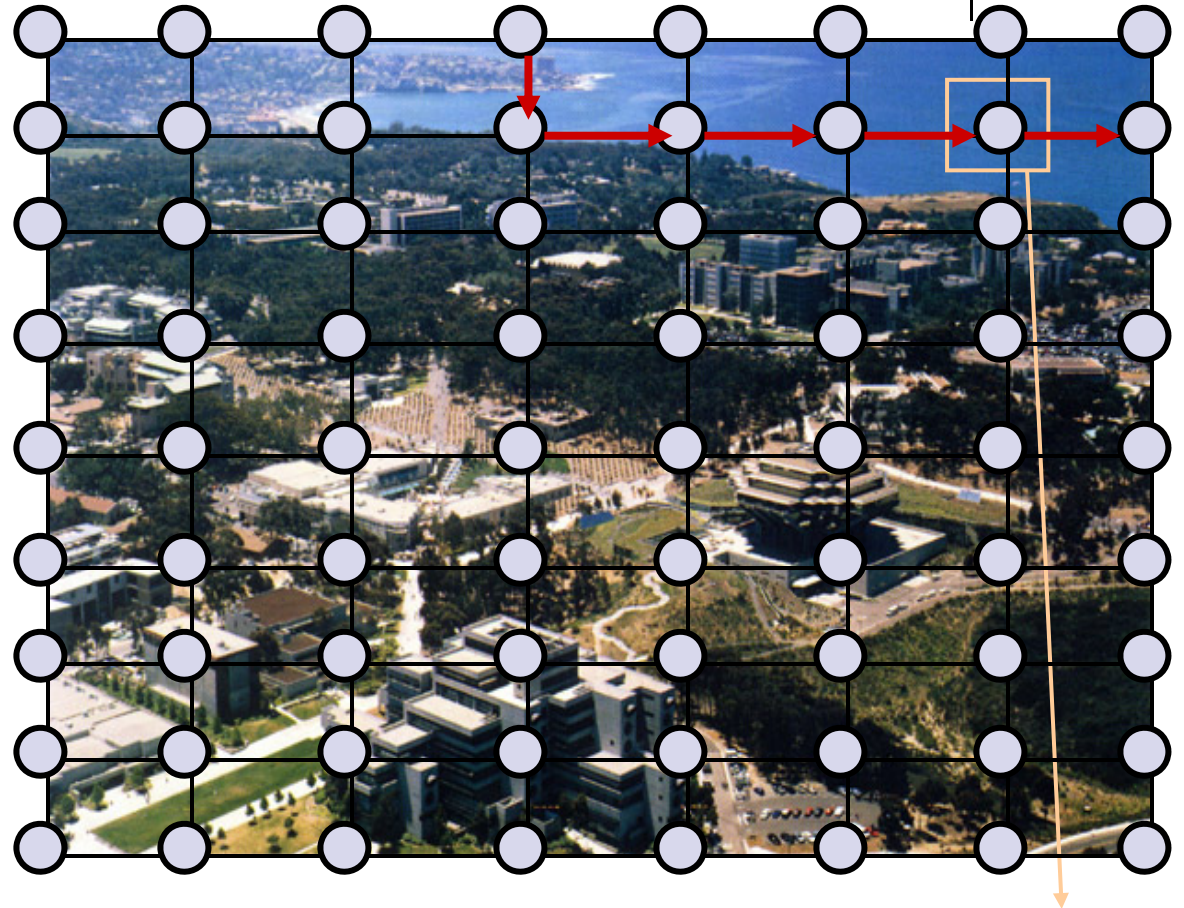

© Eric Xing @ CMU, 2005-2016

air or water ?

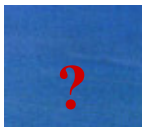



A Canonical Example

- The grid model

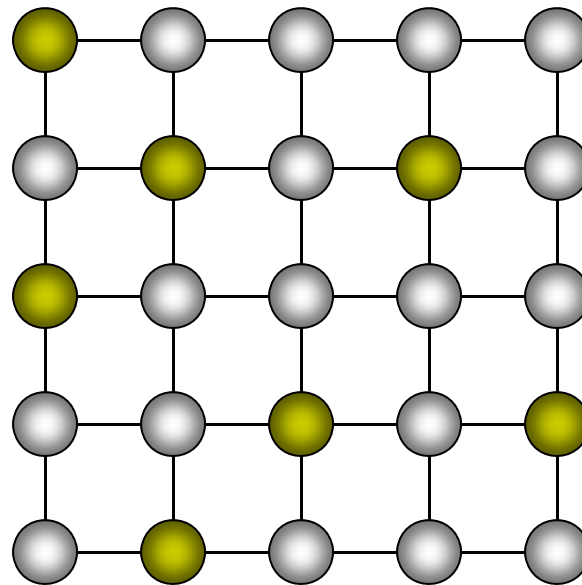

- Naturally arises in image processing, lattice physics, etc.
- Each node may represent a single "pixel", or an atom
 - The states of adjacent or nearby nodes are "coupled" due to pattern continuity or electro-magnetic force, etc.
 - Most likely joint-configurations usually correspond to a "low-energy" state



Social networks

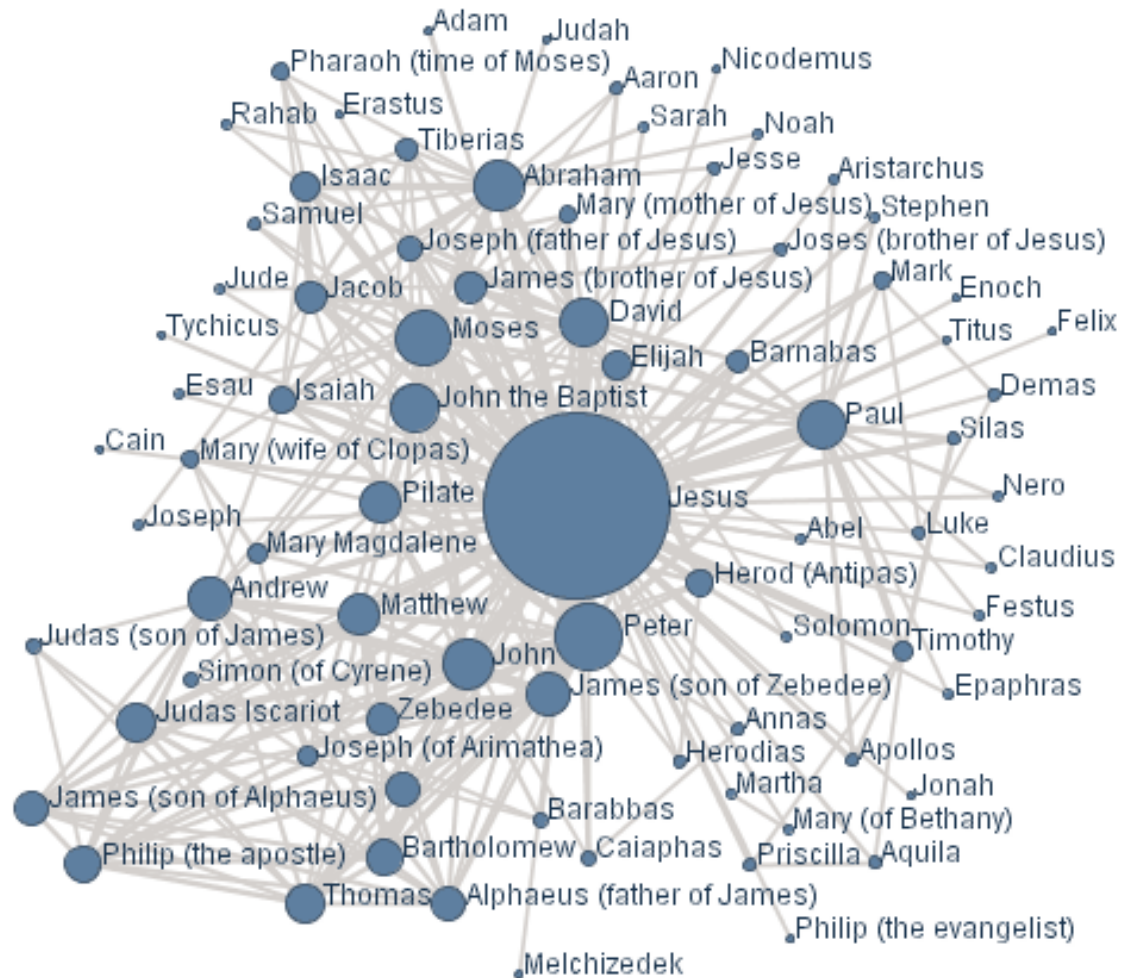

The New Testament Social Networks

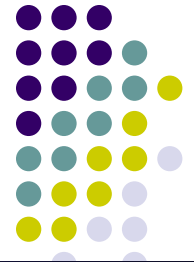

Protein interaction networks

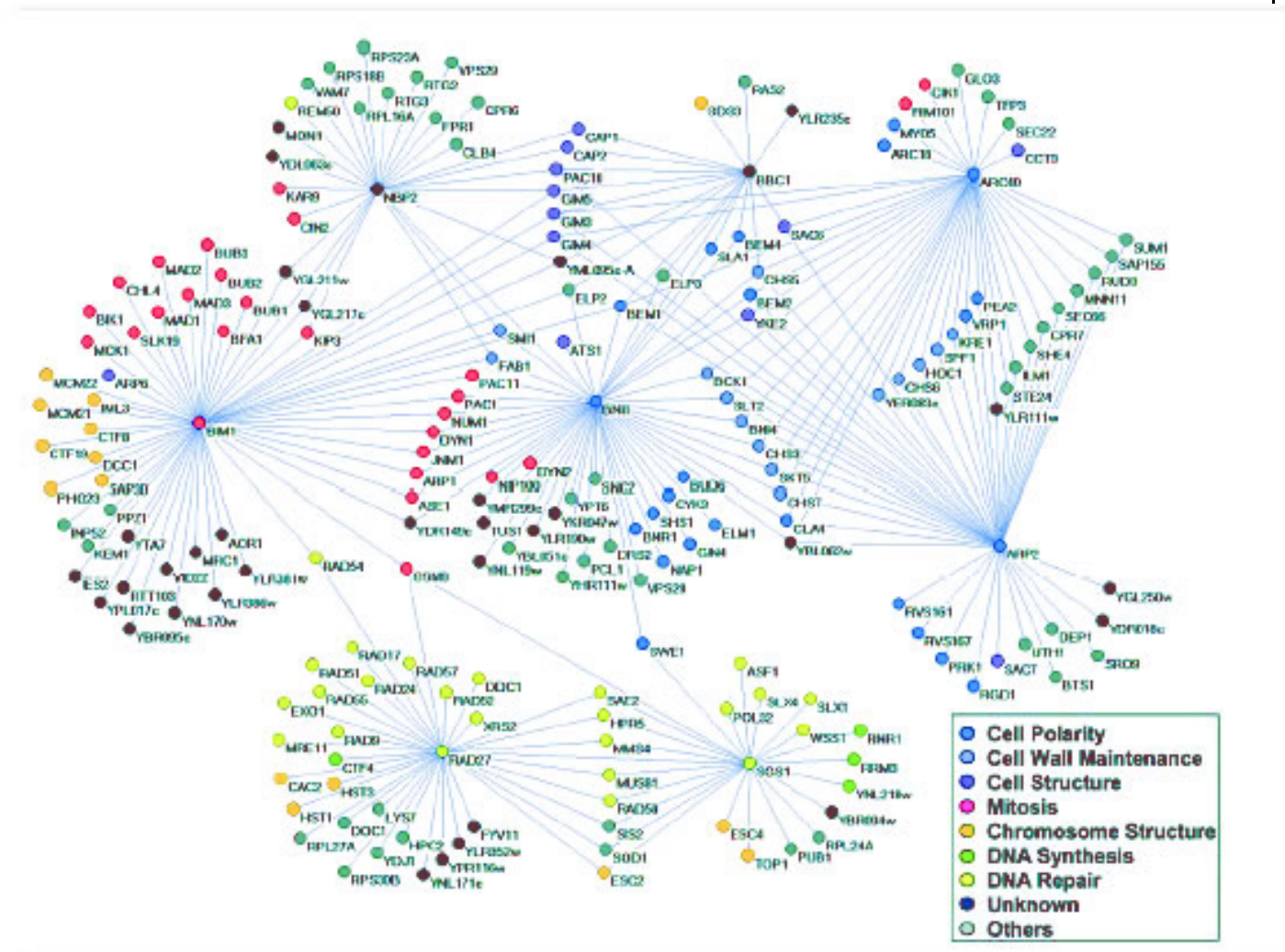

Modeling Go

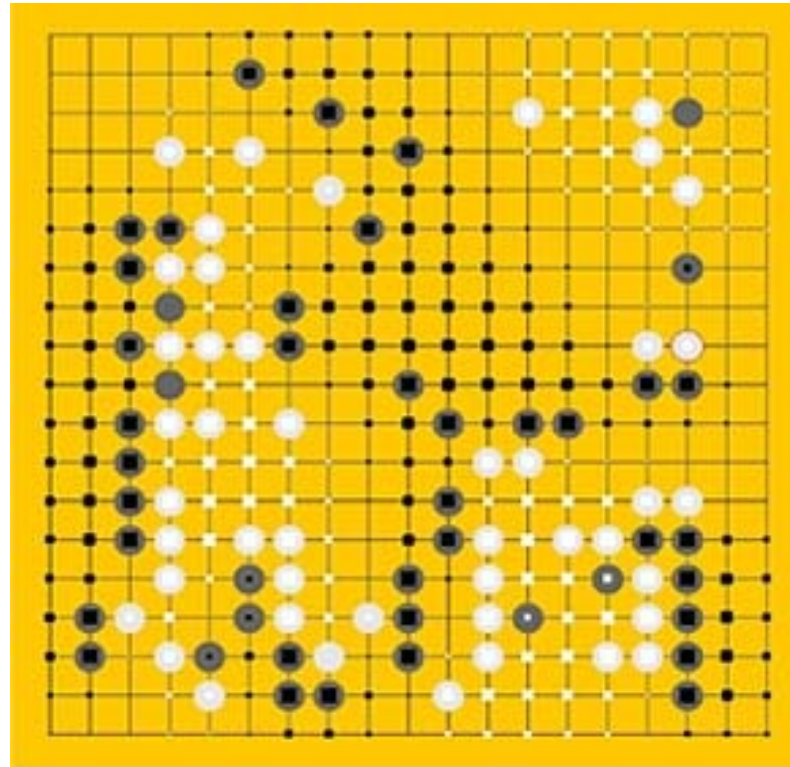

This is the middle position of a Go game.
Overlaid is the estimate for the probability of becoming black or white for every intersection.
Large squares mean the probability is higher.

Information retrieval

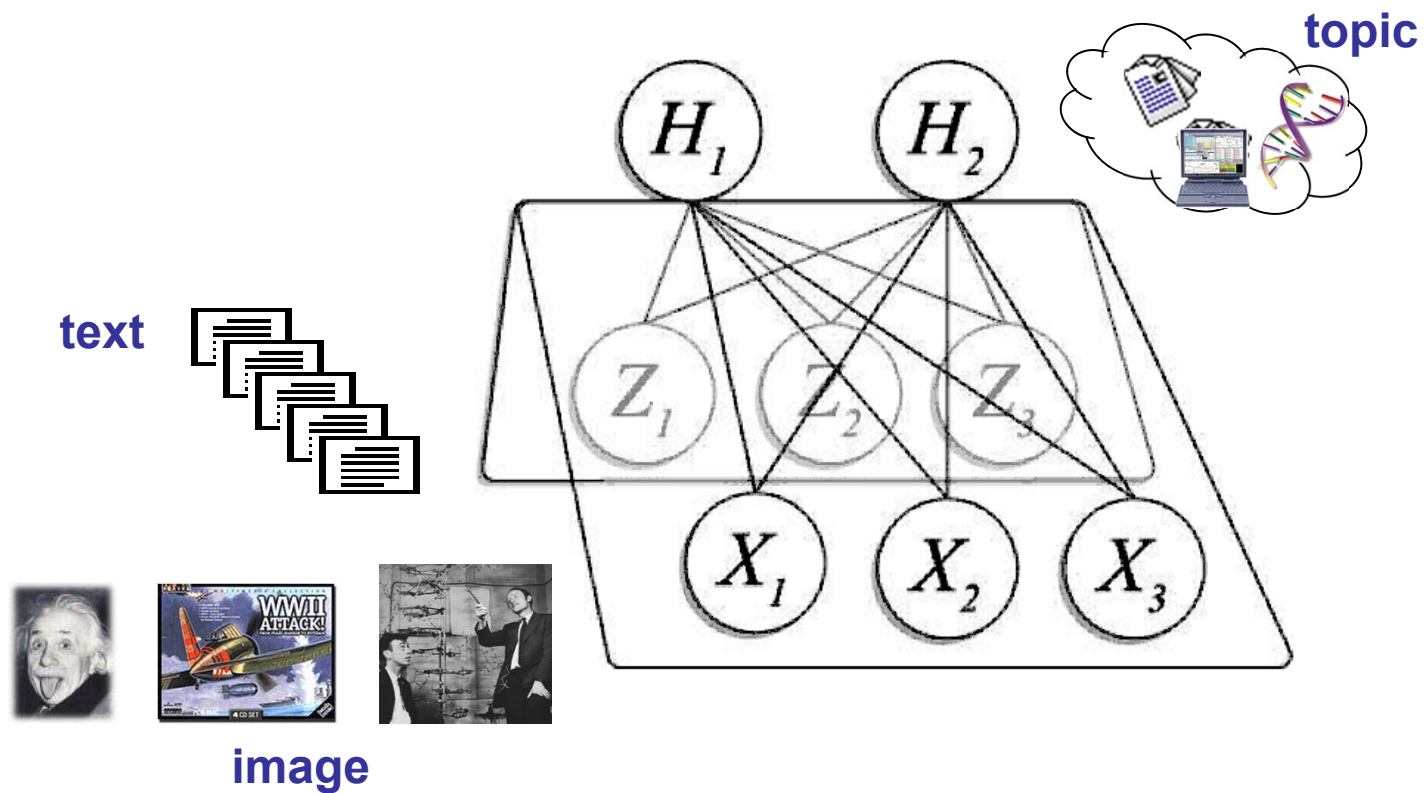



Representation

- Defn: an **undirected graphical model** represents a distribution $P(X_1, \dots, X_n)$ defined by an undirected graph H , and a set of positive **potential functions** ψ_c associated with the cliques of H , s.t.

$$P(x_1, \dots, x_n) = \frac{1}{Z} \prod_{c \in C} \psi_c(\mathbf{x}_c)$$

where Z is known as the partition function:

$$Z = \sum_{x_1, \dots, x_n} \prod_{c \in C} \psi_c(\mathbf{x}_c)$$

- Also known as **Markov Random Fields, Markov networks** ...
- The **potential function** can be understood as an contingency function of its arguments assigning "pre-probabilistic" score of their joint configuration.

I. Quantitative Specification: Cliques



- For $G=\{V,E\}$, a complete subgraph (clique) is a subgraph $G'=\{V'\subseteq V,E'\subseteq E\}$ such that nodes in V' are fully interconnected
- A (maximal) clique is a complete subgraph s.t. any **superset** $V''\supset V'$ is not complete.
- A sub-clique is a not-necessarily-maximal clique.

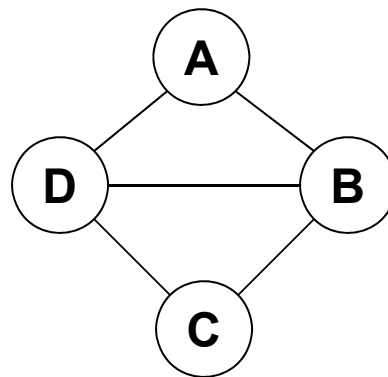

- Example:
 - max-cliques = $\{A,B,D\}, \{B,C,D\}$,
 - sub-cliques = $\{A,B\}, \{C,D\}, \dots \rightarrow$ all edges and singletons

Gibbs Distribution and Clique Potential

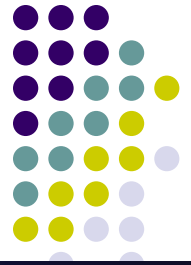

- Defn: an **undirected graphical model** represents a distribution $P(X_1, \dots, X_n)$ defined by an undirected graph H , and a **set** of positive **potential functions** ψ_c associated with cliques of H , s.t.

$$P(x_1, \dots, x_n) = \frac{1}{Z} \prod_{c \in C} \psi_c(\mathbf{x}_c) \quad (\text{A Gibbs distribution})$$

where Z is known as the partition function:

$$Z = \sum_{x_1, \dots, x_n} \prod_{c \in C} \psi_c(\mathbf{x}_c)$$

- Also known as **Markov Random Fields**, **Markov networks** ...
- The **potential function** can be understood as an contingency function of its arguments assigning "pre-probabilistic" score of their joint configuration.



Interpretation of Clique Potentials

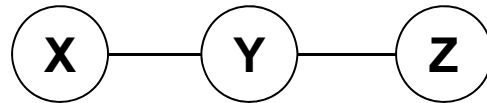

- The model implies $X \perp Z | Y$. This independence statement implies (by definition) that the joint must factorize as:

$$p(x, y, z) = p(y)p(x | y)p(z | y)$$

- We can write this as: $p(x, y, z) = p(x, y)p(z | y)$, but $p(x, y, z) = p(x | y)p(z, y)$

- **cannot** have all potentials be **marginals**
- **cannot** have all potentials be **conditionals**
- The positive clique potentials can only be thought of as general "compatibility", "goodness" or "happiness" functions over their variables, but not as probability distributions.

Example UGM – using max cliques

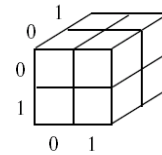
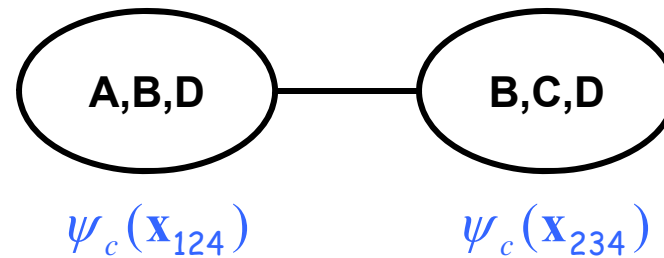
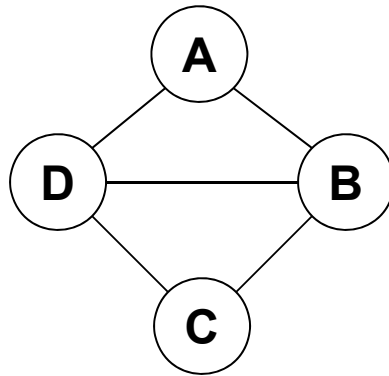
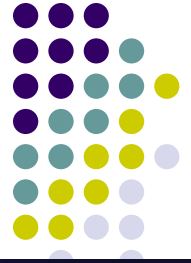

$$P'(x_1, x_2, x_3, x_4) = \frac{1}{Z} \psi_c(\mathbf{x}_{124}) \times \psi_c(\mathbf{x}_{234})$$

$$Z = \sum_{x_1, x_2, x_3, x_4} \psi_c(\mathbf{x}_{124}) \times \psi_c(\mathbf{x}_{234})$$

- For discrete nodes, we can represent $P(X_{1:4})$ as two 3D tables instead of one 4D table



Example UGM – using subcliques

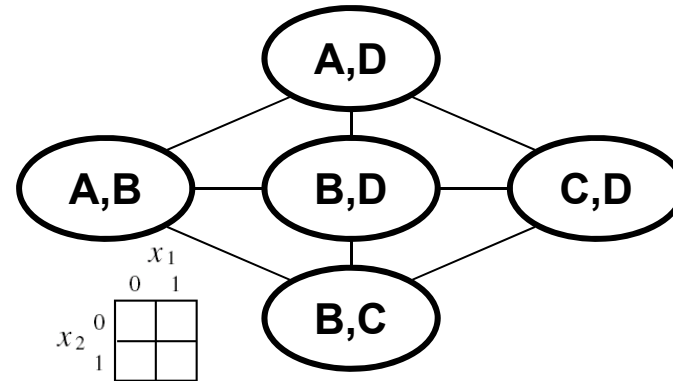
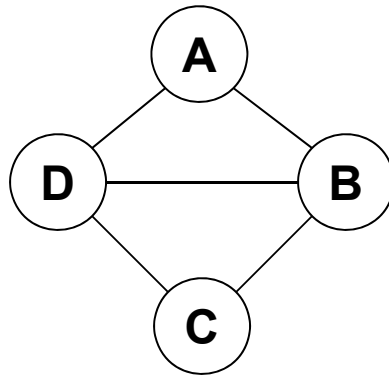

	x_1	
	0	1
x_2	0	1
	1	1

$$P''(x_1, x_2, x_3, x_4) = \frac{1}{Z} \prod_{ij} \psi_{ij}(x_{ij})$$

$$= \frac{1}{Z} \psi_{12}(x_{12}) \psi_{14}(x_{14}) \psi_{23}(x_{23}) \psi_{24}(x_{24}) \psi_{34}(x_{34})$$

$$Z = \sum_{x_1, x_2, x_3, x_4} \prod_{ij} \psi_{ij}(x_{ij})$$

- We can represent $P(X_{1:4})$ as 5 2D tables instead of one 4D table
- Pair MRFs, a popular and simple special case
- $I(P')$ vs. $I(P'')$? $D(P')$ vs. $D(P'')$

Example UGM – canonical representation

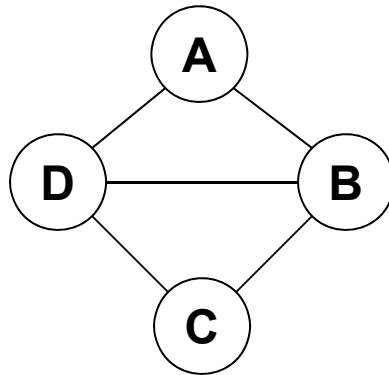
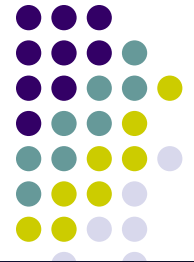

$$\begin{aligned}
 P(x_1, x_2, x_3, x_4) &= \frac{1}{Z} \psi_c(\mathbf{x}_{124}) \times \psi_c(\mathbf{x}_{234}) \\
 &\quad \times \psi_{12}(\mathbf{x}_{12}) \psi_{14}(\mathbf{x}_{14}) \psi_{23}(\mathbf{x}_{23}) \psi_{24}(\mathbf{x}_{24}) \psi_{34}(\mathbf{x}_{34}) \\
 &\quad \times \psi_1(x_1) \psi_2(x_2) \psi_3(x_3) \psi_4(x_4)
 \end{aligned}$$

$$Z = \sum_{x_1, x_2, x_3, x_4} \psi_c(\mathbf{x}_{124}) \times \psi_c(\mathbf{x}_{234}) \times \psi_{12}(\mathbf{x}_{12}) \psi_{14}(\mathbf{x}_{14}) \psi_{23}(\mathbf{x}_{23}) \psi_{24}(\mathbf{x}_{24}) \psi_{34}(\mathbf{x}_{34}) \times \psi_1(x_1) \psi_2(x_2) \psi_3(x_3) \psi_4(x_4)$$

- Most general, subsume P' and P'' as special cases
- I(P) vs. I(P') vs. I(P'')
- D(P) vs. D(P') vs. D(P'')



II: Independence properties:

- Now let us ask what kinds of distributions can be represented by undirected graphs (ignoring the details of the particular parameterization).
- Defn: the global Markov properties of a UG H are

$$I(H) = \{X \perp Z | Y) : \text{sep}_H(X; Z | Y)\}$$

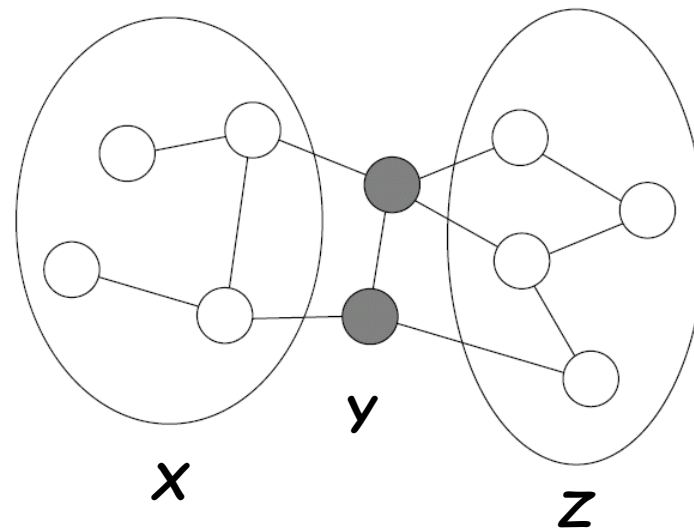



Global Markov Independencies

- Let H be an undirected graph:

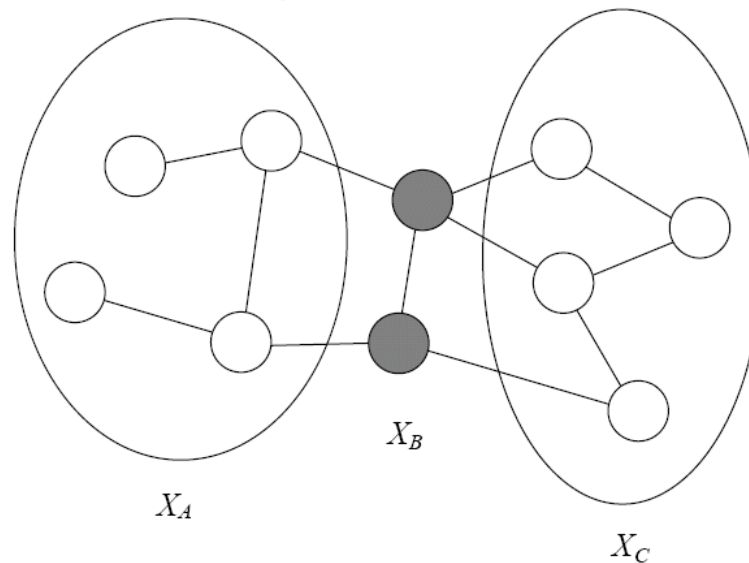

- B **separates** A and C if every path from a node in A to a node in C passes through a node in B : $sep_H(A; C|B)$
- A probability distribution satisfies the **global Markov property** if for any disjoint A, B, C , such that B separates A and C , A is independent of C given B : $I(H) = \{A \perp C|B : sep_H(A; C|B)\}$



Local Markov independencies

- For each node $X_i \in \mathbf{V}$, there is *unique Markov blanket* of X_i , denoted MB_{X_i} , which is the set of neighbors of X_i in the graph (those that share an edge with X_i)

- **Defn:**

The *local Markov independencies* associated with H is:

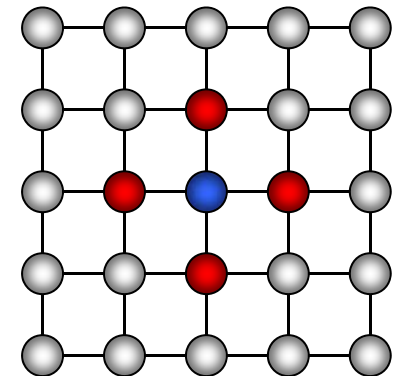

$$I_{\ell}(H): \{X_i \perp \mathbf{V} - \{X_i\} - MB_{X_i} \mid MB_{X_i} : \forall i\},$$

In other words, X_i is independent of the rest of the nodes in the graph given its immediate neighbors

Soundness and completeness of global Markov property



- Defn: An UG H is an I-map for a distribution P if $I(H) \subseteq I(P)$, i.e., P entails $I(H)$.
- Defn: P is a **Gibbs distribution** over H if it can be represented as

$$P(x_1, \dots, x_n) = \frac{1}{Z} \prod_{c \in \mathcal{C}} \psi_c(x_c)$$

- Thm (soundness): If P is a Gibbs distribution over H , then H is an I-map of P .
- Thm (completeness): If $\neg \text{sep}_H(X; Z | Y)$, then $X \not\perp_P Z | Y$ in **some** P that factorizes over H .



Other Markov properties

- For directed graphs, we defined I-maps in terms of local Markov properties, and derived global independence.
- For undirected graphs, we defined I-maps in terms of global Markov properties, and will now derive local independence.
- Defn: The *pairwise Markov independencies* associated with UG $H = (V;E)$ are

$$I_p(H) = \{X \perp Y | V \setminus \{X, Y\} : \{X, Y\} \notin E\}$$

- e.g., $X_1 \perp X_5 | \{X_2, X_3, X_4\}$

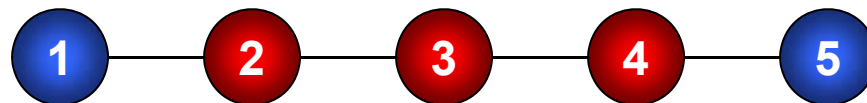

Relationship between local and global Markov properties



- Thm 5.5.5. If $P \models I_l(H)$ then $P \models I_\rho(H)$.
- Thm 5.5.6. If $P \models I(H)$ then $P \models I_l(H)$.
- Thm 5.5.7. If $P > 0$ and $P \models I_\rho(H)$, then $P \models I(H)$.
- **Corollary (5.5.8):** The following three statements are equivalent for a *positive distribution* P :

$$P \models I_l(H)$$

$$P \models I_\rho(H)$$

$$P \models I(H)$$

- This equivalence relies on the positivity assumption.
- We can design a distribution locally



Hammersley-Clifford Theorem

- If arbitrary potentials are utilized in the following product formula for probabilities,

$$P(x_1, \dots, x_n) = \frac{1}{Z} \prod_{c \in C} \psi_c(\mathbf{x}_c)$$

$$Z = \sum_{x_1, \dots, x_n} \prod_{c \in C} \psi_c(\mathbf{x}_c)$$

then the family of probability distributions obtained is exactly that set which **respects** the *qualitative specification* (the conditional independence relations) described earlier

- **Thm** : Let P be a **positive** distribution over \mathbf{V} , and H a Markov network graph over \mathbf{V} . If H is an I-map for P , then P is a Gibbs distribution over H .



Perfect maps

- Defn: A Markov network H is a perfect map for P if for any $X; Y; Z$ we have that

$$\text{sep}_H(X; Z | Y) \Leftrightarrow P \models (X \perp Z | Y)$$

- Thm: not every distribution has a perfect map as UGM.
 - Pf by counterexample. No undirected network can capture all and only the independencies encoded in a v-structure $X \rightarrow Z \leftarrow Y$.

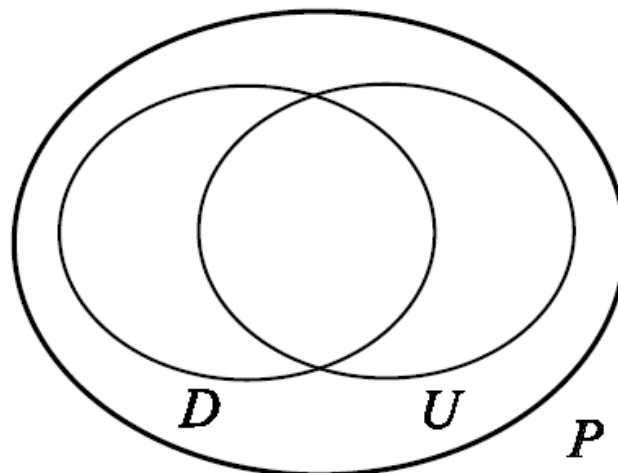



Exponential Form

- Constraining clique potentials to be positive could be inconvenient (e.g., the interactions between a pair of atoms can be either attractive or repulsive). We represent a clique potential $\psi_c(\mathbf{x}_c)$ in an unconstrained form using a real-value "energy" function $\phi_c(\mathbf{x}_c)$:

$$\psi_c(\mathbf{x}_c) = \exp\{-\phi_c(\mathbf{x}_c)\}$$

For convenience, we will call $\phi_c(\mathbf{x}_c)$ a potential when no confusion arises from the context.

- This gives the joint a nice additive structure

$$p(\mathbf{x}) = \frac{1}{Z} \exp\left\{-\sum_{c \in C} \phi_c(\mathbf{x}_c)\right\} = \frac{1}{Z} \exp\{-H(\mathbf{x})\}$$

where the sum in the exponent is called the "free energy":

$$H(\mathbf{x}) = \sum_{c \in C} \phi_c(\mathbf{x}_c)$$

- In physics, this is called the "Boltzmann distribution".
- In statistics, this is called a log-linear model.



Example: Boltzmann machines

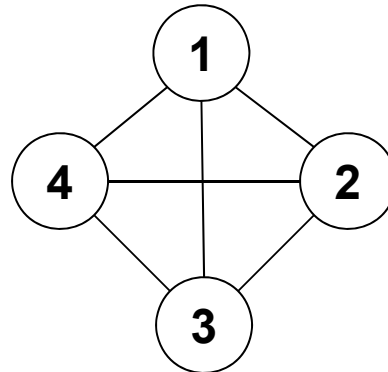

- A fully connected graph with pairwise (edge) potentials on binary-valued nodes (for $x_i \in \{-1, +1\}$ or $x_i \in \{0, 1\}$) is called a Boltzmann machine

$$\begin{aligned} P(x_1, x_2, x_3, x_4) &= \frac{1}{Z} \exp \left\{ \sum_{ij} \phi_{ij}(x_i, x_j) \right\} \\ &= \frac{1}{Z} \exp \left\{ \sum_{ij} \theta_{ij} x_i x_j + \sum_i \alpha_i x_i + C \right\} \end{aligned}$$

- Hence the overall energy function has the form:

$$H(x) = \sum_{ij} (x_i - \mu) \Theta_{ij} (x_j - \mu) = (x - \mu)^T \Theta (x - \mu)$$



Ising models

- Nodes are arranged in a regular topology (often a regular packing grid) and connected only to their geometric neighbors.

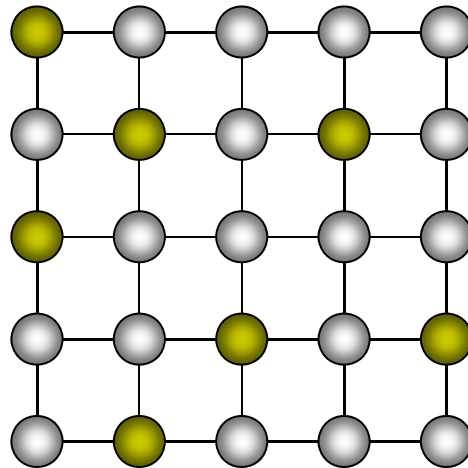

$$p(X) = \frac{1}{Z} \exp \left\{ \sum_{i,j \in N_i} \theta_{ij} X_i X_j + \sum_i \theta_{i0} X_i \right\}$$

- Same as sparse Boltzmann machine, where $\theta_{ij} \neq 0$ iff i, j are neighbors.
 - e.g., nodes are pixels, potential function encourages nearby pixels to have similar intensities.
- **Potts model**: multi-state Ising model.

Restricted Boltzmann Machines



hidden units

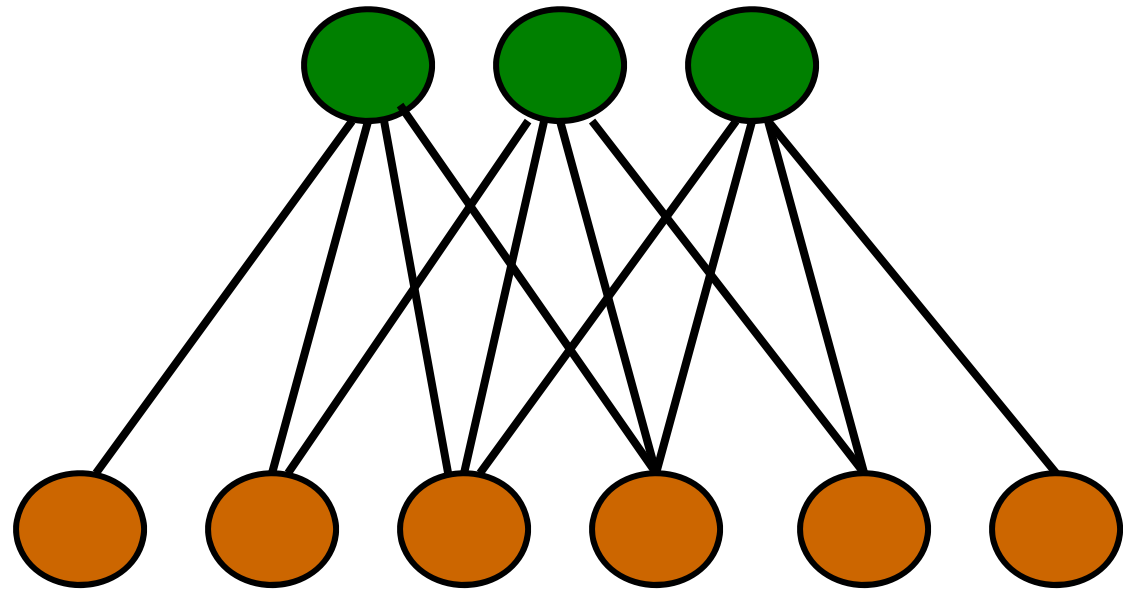

visible units

$$p(x, h | \theta) = \exp \left\{ \sum_i \theta_i \phi_i(x_i) + \sum_j \theta_j \phi_j(h_j) + \sum_{i,j} \theta_{i,j} \phi_{i,j}(x_i, h_j) - A(\theta) \right\}$$

Restricted Boltzmann Machines



The Harmonium (Smolensky –'86)

hidden units

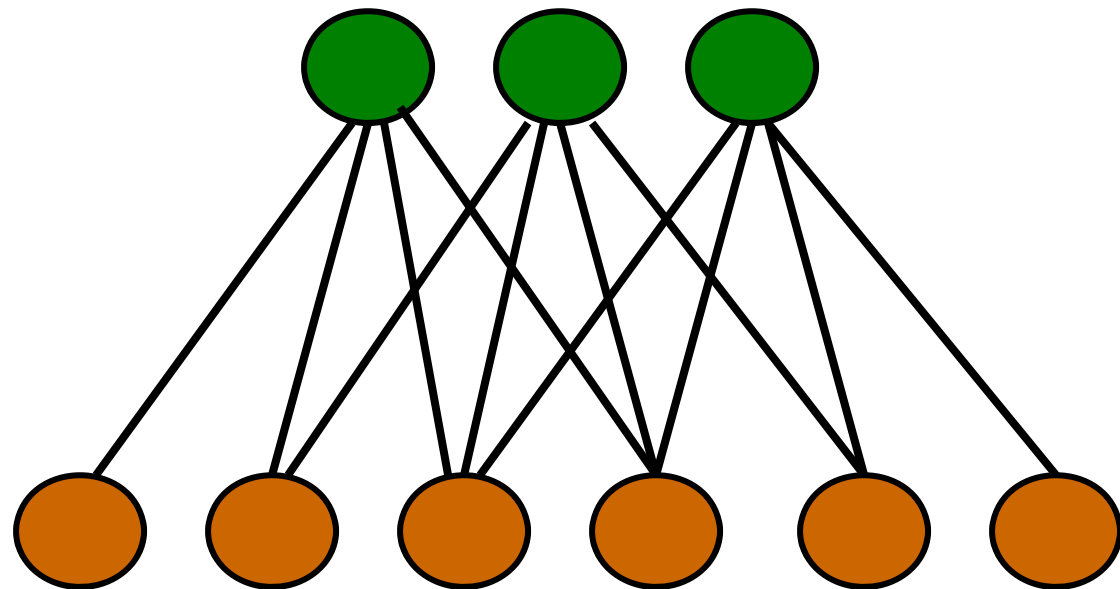

visible units

History:

Smolensky ('86), Proposed the architecture.

Freund & Haussler ('92), The “Combination Machine” (binary), learning with projection pursuit.

Hinton ('02), The “Restricted Boltzman Machine” (binary), learning with contrastive divergence.

Marks & Movellan ('02), Diffusion Networks (Gaussian).

Welling, Hinton, Osindero ('02), “Product of Student-T Distributions” (super-Gaussian)

Properties of RBM

- Factors are marginally *dependent*.
- Factors are conditionally *independent* given observations on the visible nodes.

$$P(\ell | \mathbf{w}) = \prod_i P(\ell_i | \mathbf{w})$$

- Iterative Gibbs sampling.

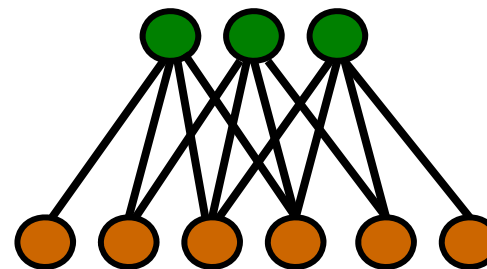

$$h \sim p(h | x)$$
$$x \sim p(x | h)$$

- Learning with contrastive divergence

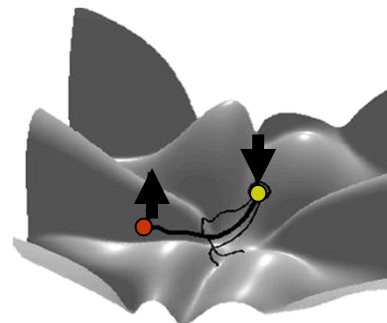



A Constructive Definition

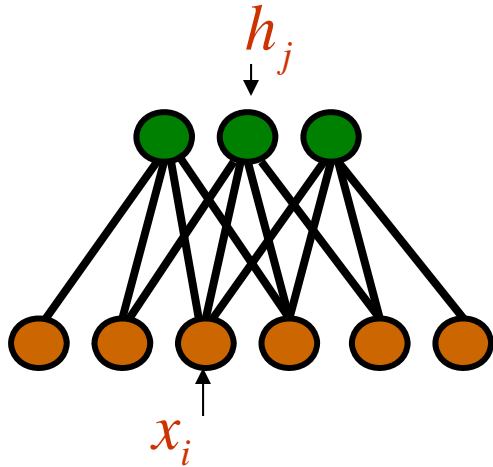

$$p_{\text{ind}}(\mathbf{h}) \propto \prod_j \exp\{ \theta_j g_j(h_j) \}$$

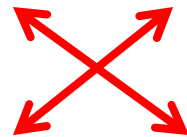

how do we couple them?

$$p_{\text{ind}}(\mathbf{x}) \propto \prod_i \exp\{ \theta_i f_i(x_i) \}$$

$$p(x, h | \theta) = \exp\left\{ \sum_i \bar{\theta}_i \vec{f}_i(x_i) + \sum_j \vec{\lambda}_j \vec{g}_j(h_j) + \sum_{i,j} \vec{f}_i^T(x_i) \mathbf{W}_{i,j} \vec{g}_j(h_j) \right\}$$



A Constructive Definition

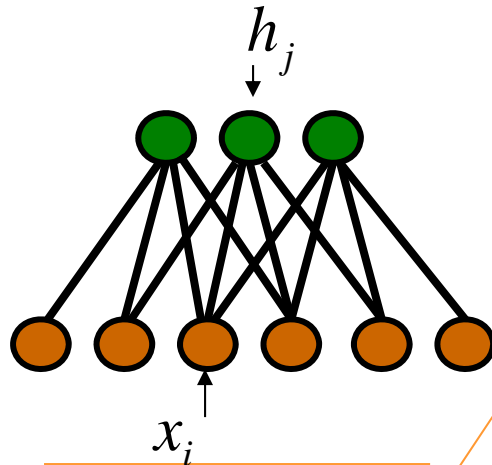

coupling in the log-domain with shifted parameters

vector of local sufficient statistics (features)

$$p(\mathbf{x} | \mathbf{h}) = \prod_i p(x_i | \mathbf{h}),$$

$$p(x_i | \mathbf{h}) = \exp\left\{ \sum_a \hat{\theta}_{ia} f_{ia}(x_i) + A_i(\{\hat{\theta}_{ia}\}) \right\}$$

$$\hat{\theta}_{ia} = \theta_{ia} + \sum_{jb} W_{ia}^{jb} g_{jb}(h_j) = \theta_{ia} + \sum_j \vec{W}_{ia}^j \vec{g}_j(h_j)$$

$$p(\mathbf{h} | \mathbf{x}) = \prod_j p(h_j | \mathbf{x})$$

$$p(h_j | \mathbf{x}) = \exp\left\{ \sum_b \hat{\lambda}_{jb} g_{jb}(h_j) + B_j(\{\hat{\lambda}_{jb}\}) \right\}$$

$$\hat{\lambda}_{jb} = \lambda_{jb} + \sum_{ia} W_{ia}^{jb} f_{ia}(x_i) = \lambda_{jb} + \sum_i \vec{W}_i^{jb} \vec{f}_i(x_i)$$

They map to the RBM random field:

$$p(x, h | \theta) = \exp\left\{ \sum_i \bar{\theta}_i \vec{f}_i(x_i) + \sum_j \bar{\lambda}_j \vec{g}_j(h_j) + \sum_{i,j} \vec{f}_i^T(x_i) \mathbf{W}_{i,j} \vec{g}_j(h_j) \right\}$$



An RBM for Text Modeling

topics

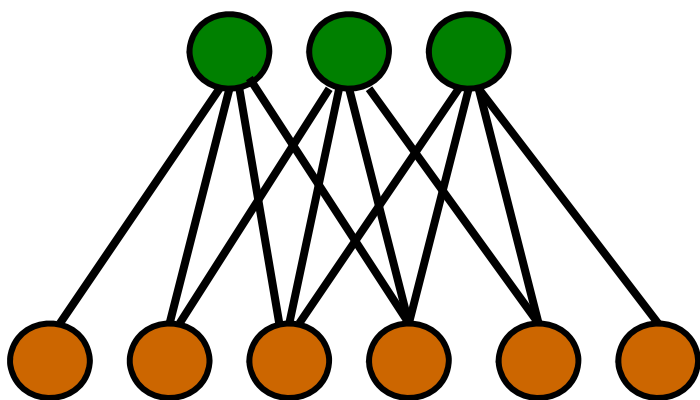

words counts

$h_j = 3$: topic j has strength 3

$$h_j \in \mathbf{R}, \quad \langle h_j \rangle = \sum_i W_{i,j} x_i$$

$x_i = \mathbf{n}$: word i has count n

$$x_i \in \mathbf{I}$$

$$p(\mathbf{h} | \mathbf{x}) = \prod_j \text{Normal}_{h_j} \left[\sum_i \vec{W}_{ij} \vec{x}_i, 1 \right]$$

$$p(\mathbf{x} | \mathbf{h}) = \prod_i \text{Bi}_{x_i} \left[N, \frac{\exp(\alpha_j + \sum_j W_{ij} h_j)}{1 + \exp(\alpha_j + \sum_j W_{ij} h_j)} \right]$$

$$\Rightarrow p(\mathbf{x}) \propto \exp \left\{ \left(\sum_i \alpha_i x_i - \log \Gamma(x_i) - \log \Gamma(N - x_i) \right) + \frac{1}{2} \sum_j \left(\sum_i W_{i,j} x_i \right)^2 \right\}$$



Conditional Random Fields

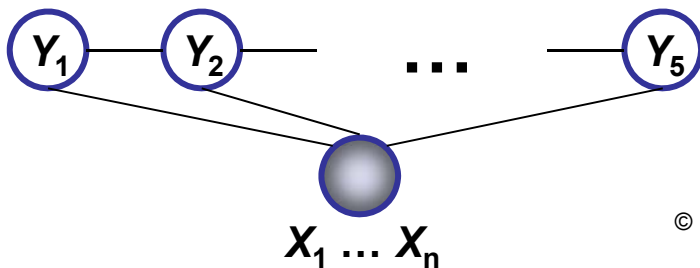
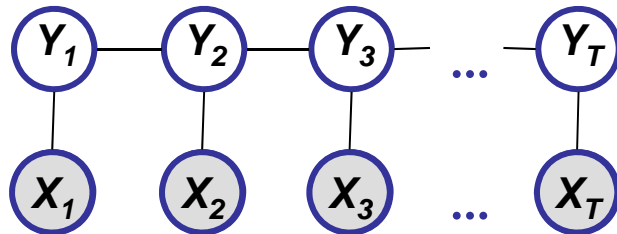
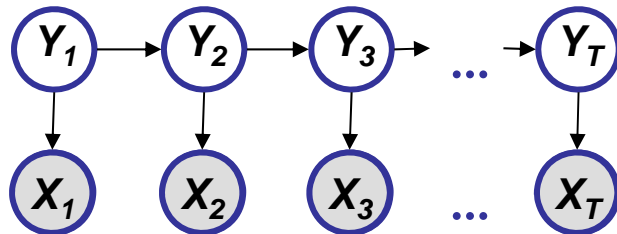

- Discriminative

$$p_{\theta}(y | x) = \frac{1}{Z(\theta, x)} \exp \left\{ \sum_c \theta_c f_c(x, y_c) \right\}$$

- Doesn't assume that features are independent
- When labeling X_i future observations are taken into account



Conditional Models

- Conditional probability $P(\text{label sequence } \mathbf{y} \mid \text{observation sequence } \mathbf{x})$ rather than joint probability $P(\mathbf{y}, \mathbf{x})$
 - Specify the probability of possible label sequences given an observation sequence
- Allow arbitrary, non-independent features on the observation sequence \mathbf{X}
- The probability of a transition between labels may depend on **past** and **future** observations
- Relax strong independence assumptions in generative models



Conditional Distribution

- If the graph $G = (V, E)$ of \mathbf{Y} is a tree, the conditional distribution over the label sequence $\mathbf{Y} = \mathbf{y}$, given $\mathbf{X} = \mathbf{x}$, by the Hammersley Clifford theorem of random fields is:

$$p_{\theta}(\mathbf{y} | \mathbf{x}) \propto \exp \left(\sum_{e \in E, k} \lambda_k f_k(e, \mathbf{y}|_e, \mathbf{x}) + \sum_{v \in V, k} \mu_k g_k(v, \mathbf{y}|_v, \mathbf{x}) \right)$$

- \mathbf{x} is a data sequence
- \mathbf{y} is a label sequence
- v is a vertex from vertex set V = set of label random variables
- e is an edge from edge set E over V
- f_k and g_k are given and fixed. g_k is a Boolean vertex feature; f_k is a Boolean edge feature
- k is the number of features
- $\theta = (\lambda_1, \lambda_2, \dots, \lambda_n; \mu_1, \mu_2, \dots, \mu_n)$; λ_k and μ_k are parameters to be estimated
- $\mathbf{y}|_e$ is the set of components of \mathbf{y} defined by edge e
- $\mathbf{y}|_v$ is the set of components of \mathbf{y} defined by vertex v

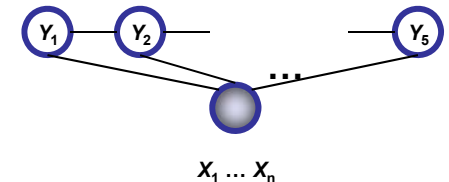



Conditional Distribution (cont'd)

- CRFs use the observation-dependent normalization $Z(\mathbf{x})$ for the conditional distributions:

$$p_{\theta}(y | \mathbf{x}) = \frac{1}{Z(\mathbf{x})} \exp \left(\sum_{e \in E, k} \lambda_k f_k(e, y | e, \mathbf{x}) + \sum_{v \in V, k} \mu_k g_k(v, y | v, \mathbf{x}) \right)$$

- $Z(\mathbf{x})$ is a normalization over the data sequence \mathbf{x}



Conditional Random Fields

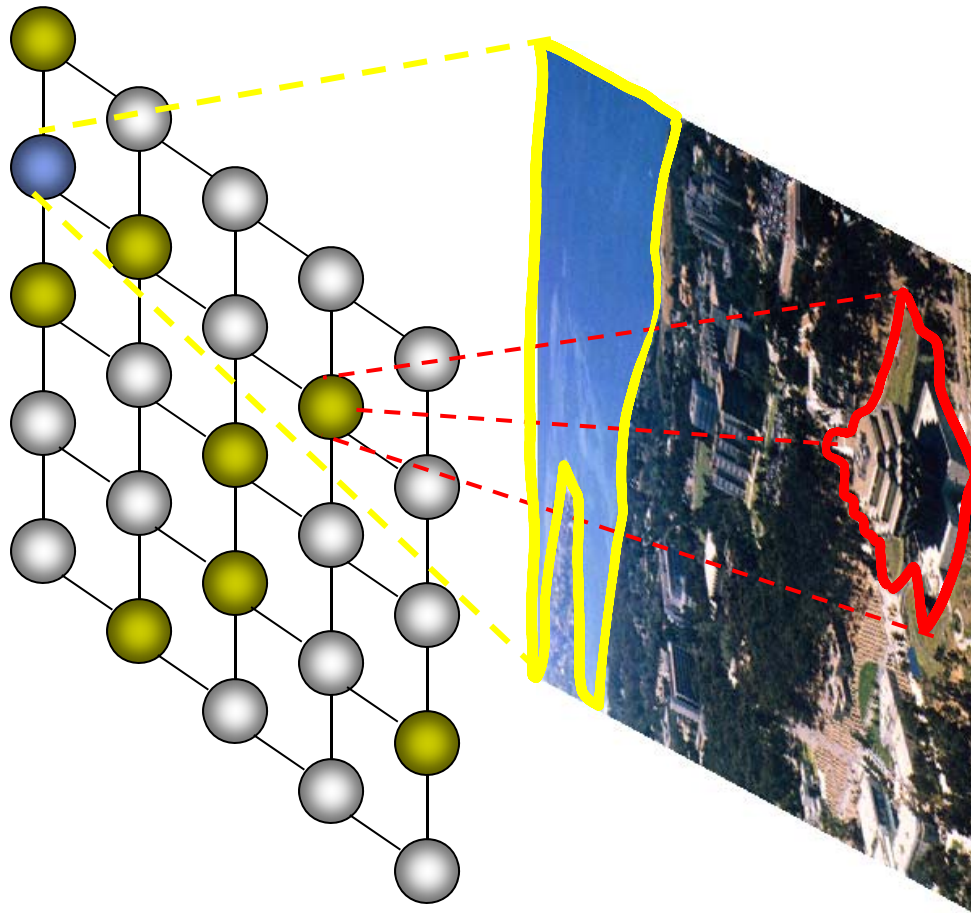

$$p_{\theta}(y | x) = \frac{1}{Z(\theta, x)} \exp \left\{ \sum_c \theta_c f_c(x, y_c) \right\}$$

- Allow arbitrary dependencies on input
- Clique dependencies on labels
- Use approximate inference for general graphs

Summary: Conditional Independence Semantics in an MRF

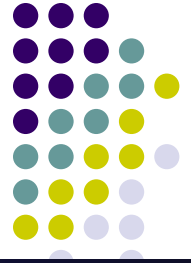

Structure: an *undirected graph*

- Meaning: a node is **conditionally independent** of every other node in the network given its **Directed neighbors**
- Local contingency functions (**potentials**) and the **cliques** in the graph completely determine the **joint dist.**
- Give **correlations** between variables, but no explicit way to generate samples

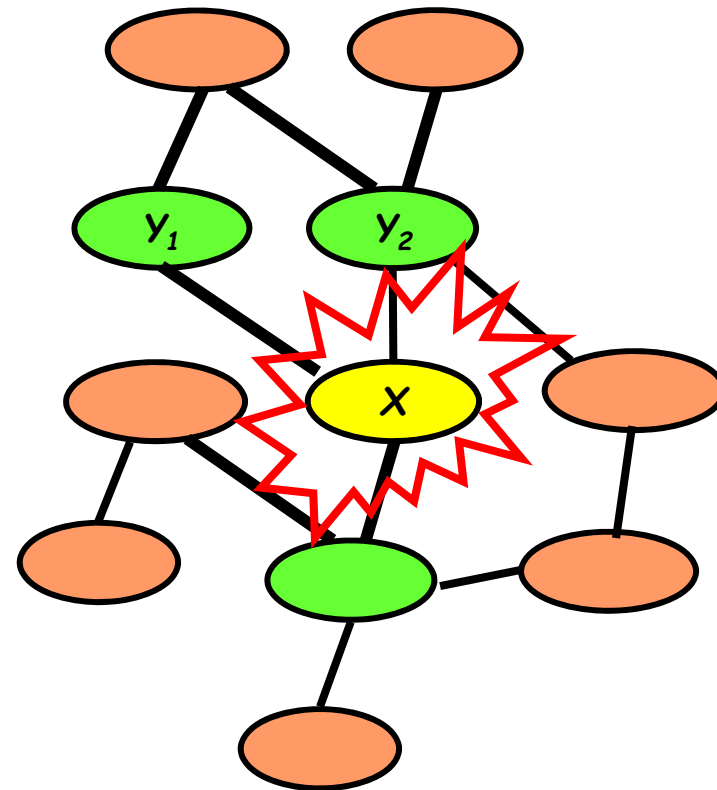

Where is the graph structure come from?



The goal:

- Given set of independent samples (*assignments* of random variables), find the *best* (the most likely?) graphical model topology

ML Structural Learning for completely observed GMs

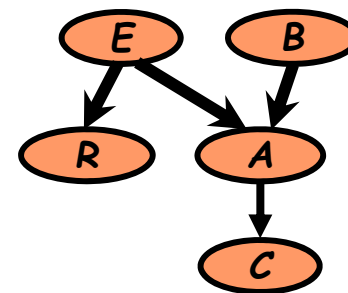
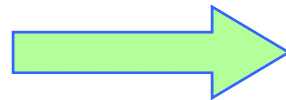
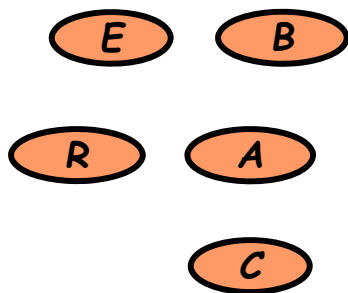

(B,E,A,C,R)=(T,F,F,T,F)

(B,E,A,C,R)=(T,F,T,T,F)

.....

(B,E,A,C,R)=(F,T,T,T,F)

Information Theoretic Interpretation of ML



$$\begin{aligned}\ell(\theta_G, G; D) &= \log p(D | \theta_G, G) \\ &= \log \prod_n \left(\prod_i p(x_{n,i} | \mathbf{x}_{n,\pi_i(G)}, \theta_{i|\pi_i(G)}) \right) \\ &= \sum_i \left(\sum_n \log p(x_{n,i} | \mathbf{x}_{n,\pi_i(G)}, \theta_{i|\pi_i(G)}) \right) \\ &= M \sum_i \left(\sum_{x_i, \mathbf{x}_{\pi_i(G)}} \frac{\text{count}(x_i, \mathbf{x}_{\pi_i(G)})}{M} \log p(x_i | \mathbf{x}_{\pi_i(G)}, \theta_{i|\pi_i(G)}) \right) \\ &= M \sum_i \left(\sum_{x_i, \mathbf{x}_{\pi_i(G)}} \hat{p}(x_i, \mathbf{x}_{\pi_i(G)}) \log p(x_i | \mathbf{x}_{\pi_i(G)}, \theta_{i|\pi_i(G)}) \right)\end{aligned}$$

From sum over data points to sum over count of variable states

Information Theoretic Interpretation of ML (con'd)



$$\begin{aligned}\ell(\theta_G, G; D) &= \log \hat{p}(D | \theta_G, G) \\ &= M \sum_i \left(\sum_{x_i, \mathbf{x}_{\pi_i(G)}} \hat{p}(x_i, \mathbf{x}_{\pi_i(G)}) \log \hat{p}(x_i | \mathbf{x}_{\pi_i(G)}, \theta_{i|\pi_i(G)}) \right) \\ &= M \sum_i \left(\sum_{x_i, \mathbf{x}_{\pi_i(G)}} \hat{p}(x_i, \mathbf{x}_{\pi_i(G)}) \log \frac{\hat{p}(x_i, \mathbf{x}_{\pi_i(G)}, \theta_{i|\pi_i(G)})}{\hat{p}(\mathbf{x}_{\pi_i(G)})} \frac{\hat{p}(x_i)}{\hat{p}(x_i)} \right) \\ &= M \sum_i \left(\sum_{x_i, \mathbf{x}_{\pi_i(G)}} \hat{p}(x_i, \mathbf{x}_{\pi_i(G)}) \log \frac{\hat{p}(x_i, \mathbf{x}_{\pi_i(G)}, \theta_{i|\pi_i(G)})}{\hat{p}(\mathbf{x}_{\pi_i(G)}) \hat{p}(x_i)} \right) - M \sum_i \left(\sum_{x_i} \hat{p}(x_i) \log \hat{p}(x_i) \right) \\ &= M \sum_i \hat{I}(x_i, \mathbf{x}_{\pi_i(G)}) - M \sum_i \hat{H}(x_i)\end{aligned}$$

Decomposable score and a function of the graph structure



Structural Search

- How many graphs over n nodes? $O(2^{n^2})$
- How many trees over n nodes? $O(n!)$
- But it turns out that we can find exact solution of an optimal tree (under MLE)!
 - Trick: in a tree each node has only one parent!
 - Chow-liu algorithm

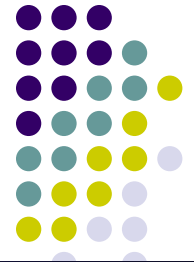

Chow-Liu tree learning algorithm

- Objection function:

$$\begin{aligned}\ell(\theta_G, G; D) &= \log \hat{p}(D | \theta_G, G) \\ &= M \sum_i \hat{I}(x_i, \mathbf{x}_{\pi_i(G)}) - M \sum_i \hat{H}(x_i)\end{aligned} \Rightarrow \boxed{C(G) = M \sum_i \hat{I}(x_i, \mathbf{x}_{\pi_i(G)})}$$

- Chow-Liu:

- For each pair of variable x_i and x_j

- Compute empirical distribution: $\hat{p}(X_i, X_j) = \frac{\text{count}(x_i, x_j)}{M}$

- Compute mutual information: $\hat{I}(X_i, X_j) = \sum_{x_i, x_j} \hat{p}(x_i, x_j) \log \frac{\hat{p}(x_i, x_j)}{\hat{p}(x_i) \hat{p}(x_j)}$

- Define a graph with node x_1, \dots, x_n
 - Edge (i,j) gets weight $\hat{I}(X_i, X_j)$



Chow-Liu algorithm (con'd)

- Objection function:

$$\begin{aligned}\ell(\theta_G, G; D) &= \log \hat{p}(D | \theta_G, G) \\ &= M \sum_i \hat{I}(x_i, \mathbf{x}_{\pi_i(G)}) - M \sum_i \hat{H}(x_i)\end{aligned} \Rightarrow C(G) = M \sum_i \hat{I}(x_i, \mathbf{x}_{\pi_i(G)})$$

- Chow-Liu:

Optimal tree BN

- Compute maximum weight spanning tree
- Direction in BN: pick any node as root, do breadth-first-search to define directions
- I-equivalence:

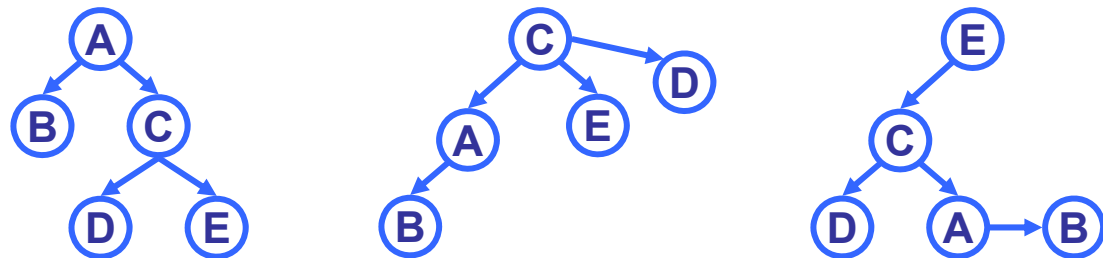

$$C(G) = I(A, B) + I(A, C) + I(C, D) + I(C, E)$$

Structure Learning for general graphs

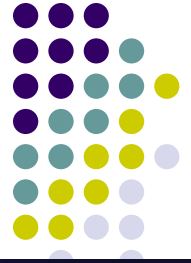

- Theorem:
 - The problem of learning a BN structure with at most d parents is NP-hard for any (fixed) $d \geq 2$
- Most structure learning approaches use heuristics
 - Exploit score decomposition
 - Two heuristics that exploit decomposition in different ways
 - Greedy search through space of node-orders
 - Local search of graph structures



Summary

- Undirected graphical models capture “relatedness”, “coupling”, “co-occurrence”, “synergism”, etc. between entities
 - Local and global independence properties identifiable via graph separation criteria
 - Defined on clique potentials
- Can be used to define either joint or conditional distributions
- Generally intractable to compute likelihood due to presence of “partition function”
 - Therefore not only inference, but also likelihood-based learning is difficult in general
- Important special cases:
 - Ising models
 - RBM
 - CRF
- Learning GM structures:
 - the Chow-Liu Algorithm