

Objects Analysis

Threads



Design

15-214

15-214

toad

Spring 2013

Principles of Software Construction: Objects, Design and Concurrency

Design Patterns

Christian Kästner

Charlie Garrod

```

C:\Temp> dir
Volume in drive C is C
Volume Serial Number is 74F5-B93C

Directory of C:\Temp

2009-08-25  11:59    <DIR>          .
2009-08-25  11:59    <DIR>          ..
2007-03-01  11:37             2,321,600 AdobeUpdater12345.exe
2009-04-03  10:01             27,988 dd_depcheckdotnetfx30.txt
2009-04-03  10:01              764 dd_dotnetfx3error.txt
2009-04-03  10:01             32,572 dd_dotnetfx3install.txt
2009-06-09  13:46             35,145 GenProfile.log
2009-08-05  12:11              155 KB969856.log
2009-04-20  08:37              402 MSI29e0b.LOG
2009-04-09  16:34             38,895 offcln11.log
2009-04-03  16:02    <DIR>          OfficePatches
2009-07-14  14:30    <DIR>          OHotfix
2009-08-25  10:52             16,384 Perflib_Perfdata_c30.dat
2009-04-03  10:01              1,744 uxeventlog.txt
2009-08-25  11:42            50,245,632 WFV2F.tmp
2009-04-20  10:07              1,397 {AC76BA86-7AD7-1033-7B44-A81200000003}.ini
2009-04-20  10:13              617 {AC76BA86-7AD7-1033-7B44-A81300000003}.ini
                13 File(s)      52,723,295 bytes
                4 Dir(s)  83,570,208,768 bytes free

```

dir.delete()

fig.move(5,10);

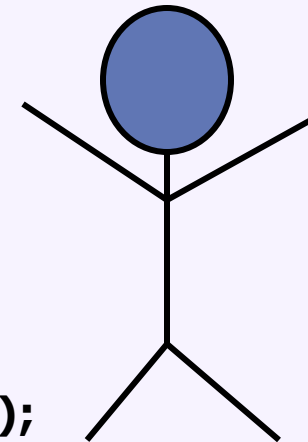

A First Pattern: Composite (Structural)

- **Applicability**

- You want to represent part-whole hierarchies of objects
- You want to be able to ignore the difference between compositions of objects and individual objects

- **Consequences**

- Makes the client simple, since it can treat objects and composites uniformly
- Makes it easy to add new kinds of components
- Can make the design overly general
 - Operations may not make sense on every class
 - Composites may contain only certain components

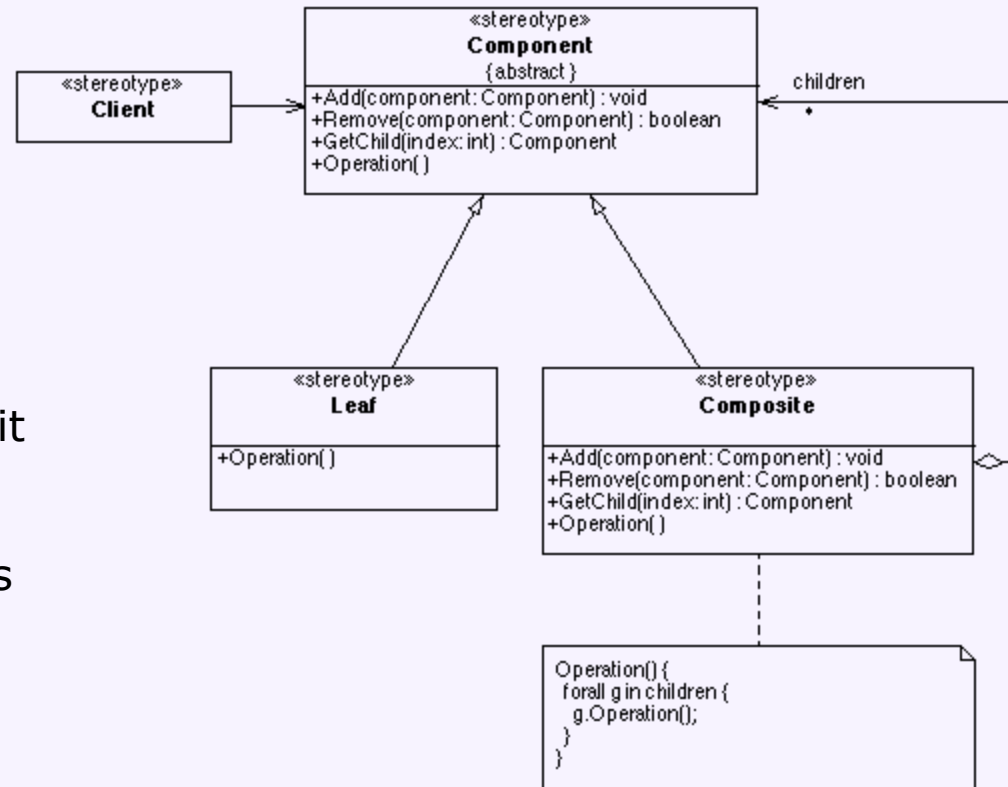

Design Patterns

- "Each pattern describes a problem which occurs over and over again in our environment, and then describes the core of the solution to that problem, in such a way that you can use this solution a million times over, without ever doing it the same way twice"
 - Christopher Alexander
- Every Composite has its own domain-specific interface
 - But they share a common problem and solution

- Christopher Alexander, *The Timeless Way of Building* (and other books)
 - Proposes patterns as a way of capturing design knowledge in architecture
 - Each pattern represents a tried-and-true solution to a design problem
 - Typically an engineering compromise that resolves conflicting forces in an advantageous way
 - Composite: you have a part-whole relationship, but want to treat individual objects and object compositions uniformly

Patterns in Physical Architecture

- When a room has a window with a view, the window becomes a focal point: people are attracted to the window and want to look through it. The furniture in the room creates a second focal point: everyone is attracted toward whatever point the furniture aims them at (usually the center of the room or a TV). This makes people feel uncomfortable. They want to look out the window, and toward the other focus at the same time. If you rearrange the furniture, so that its focal point becomes the window, then everyone will suddenly notice that the room is much more “comfortable”.
 - Leonard Budney, Amazon.com review of *The Timeless Way of Building*

Benefits of Patterns

- Shared language of design
 - Increases communication bandwidth
 - Decreases misunderstandings

- Learn from experience
 - Becoming a good designer is hard
 - Understanding good designs is a first step
 - Tested solutions to common problems
 - Where is the solution applicable?
 - What are the tradeoffs?

Illustration [Shalloway and Trott]

- Carpenter 1: How do you think we should build these drawers?
- Carpenter 2: Well, I think we should make the joint by cutting straight down into the wood, and then cut back up 45 degrees, and then going straight back down, and then back up the other way 45 degrees, and then going straight down, and repeating...

Illustration [Shalloway and Trott]

- Carpenter 1: How do you think we should build these drawers?
- Carpenter 2: Well, I think we should make the joint by cutting straight down into the wood, and then cut back up 45 degrees, and then going straight back down, and then back up the other way 45 degrees, and then going straight down, and repeating...
- SE example: "I wrote this if statement to handle ... followed by a while loop ... with a break statement so that..."

A Better Way

- Carpenter 1: Should we use a dovetail joint or a miter joint?
- Subtext:
 - miter joint: cheap, invisible, breaks easily
 - dovetail joint: expensive, beautiful, durable
- Shared terminology and knowledge of consequences raises level of abstraction
 - CS: Should we use a Composite?
 - Subtext
 - Is there a part-whole relationship here?
 - Might there be advantages to treating compositions and individuals uniformly?

Elements of a Pattern

- Name
 - Important because it becomes part of a design vocabulary
 - Raises level of communication
- Problem
 - When the pattern is applicable
- Solution
 - Design elements and their relationships
 - Abstract: must be specialized
- Consequences
 - Tradeoffs of applying the pattern
 - Each pattern has costs as well as benefits
 - Issues include flexibility, extensibility, etc.
 - There may be variations in the pattern with different consequences

History: Design Patterns Book

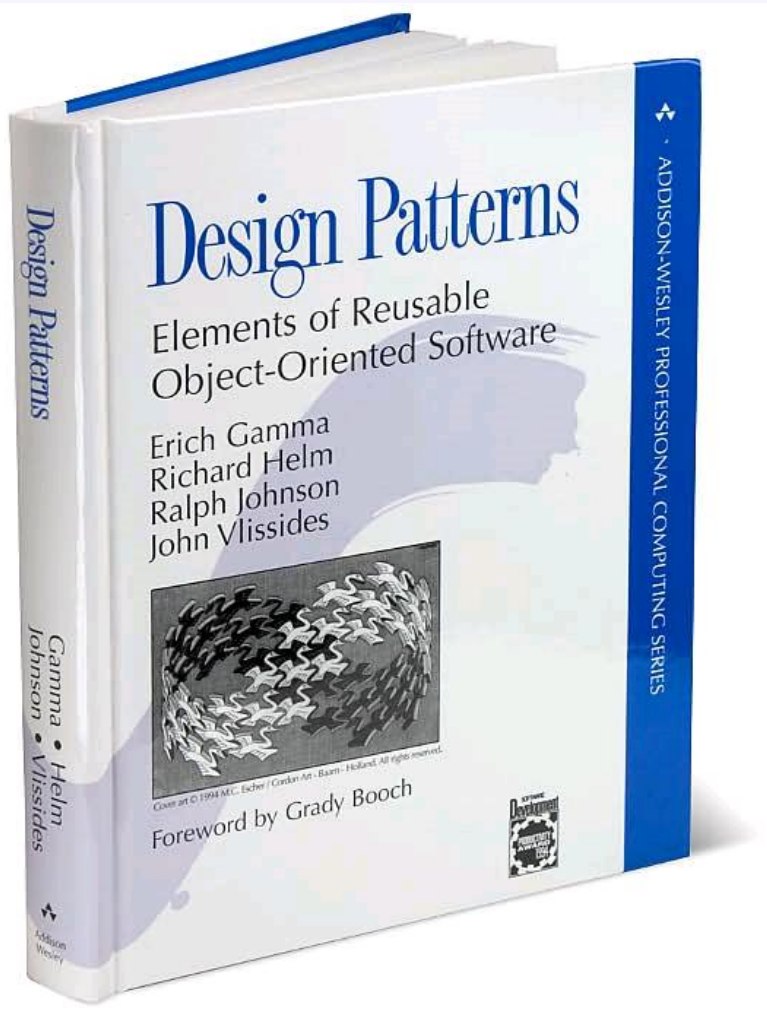

- Brought Design Patterns into the mainstream
- Authors known as the Gang of Four (GoF)
- Focuses on *descriptions of communicating objects and classes that are customized to solve a general design problem in a particular context*
- Great as a reference text
- Uses C++, Smalltalk

A More Recent Patterns Text

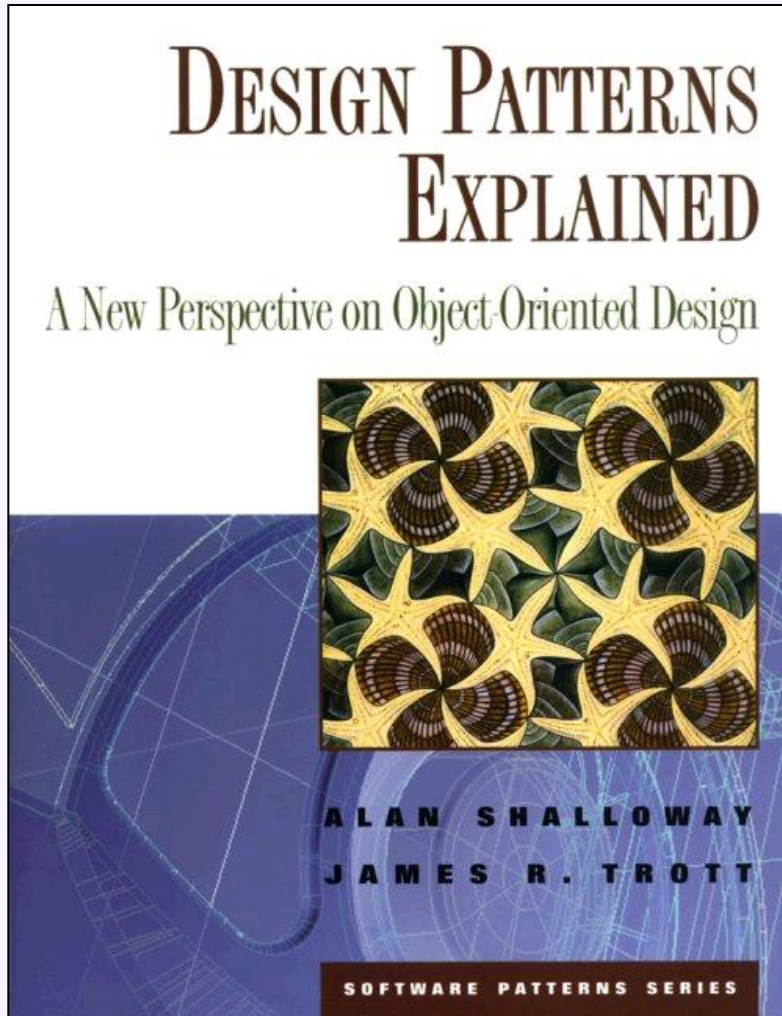

- Uses Java
 - The GoF text was written before Java went mainstream
- Good pedagogically
 - General design information
 - Lots of examples and explanation
 - GoF is really more a reference text
- Read it!

Fundamental OO Design Principles

- Patterns follow design goals
 - Modular (De)composability, Modular Continuity, Explicit Interfaces, Information Hiding, ...
- Patterns emerge from fundamental principles applied to recurring problems
 - Design to **interfaces**
 - Favor **composition** over inheritance
 - Find what **varies** and encapsulate it
- Patterns are discovered, not invented
 - Best practice by experienced developers

Patterns to Know

- Façade, Adapter, Composite, Strategy, Bridge, Abstract Factory, Factory Method, Decorator, Observer, Template Method, Singleton, Command, State, Proxy, and Model-View-Controller
- Know pattern name, problem, solution, and consequences

Specific Patterns

- Facade
- Adapter
- Strategy
- Template Method
- Factory Method
- Abstract Factory
- Decorator
- Observer
- *Command*
- *State*
- *Composite*
- Bridge
- *Singleton*
- *Proxy*
- *Visitor*

Scenario

- You need to load and print pictures in your application
- You found a library that provides far more than you need
 - Many classes
 - Different representations
 - Sophisticated image manipulation routines
- You may want to switch to a different library later
- What's the right design?

Façade (Structural)

- Applicability
 - You want to provide a simple interface to a complex subsystem
 - You want to decouple clients from the implementation of a subsystem
 - You want to layer your subsystems
- Consequences
 - It shields clients from the complexity of the subsystem, making it easier to use
 - Decouples the subsystem and its clients, making each easier to change
 - Clients that need to can still access subsystem classes

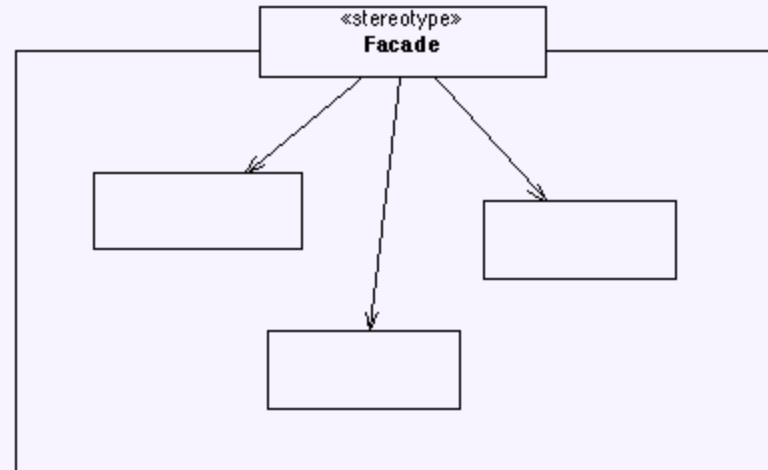

Scenario

- You have an application that processes data with an Iterator. Methods are:
 - **boolean** hasNext();
 - Object next();
- You need to read that data from a database using JDBC. Methods are:
 - **boolean** next();
 - Object getObject(int column);
- You might have to get the information from other sources in the future.

Structural: Adapter

- Applicability

- You want to use an existing class, and its interface does not match the one you need
- You want to create a reusable class that cooperates with unrelated classes that don't necessarily have compatible interfaces
- You need to use several subclasses, but it's impractical to adapt their interface by subclassing each one

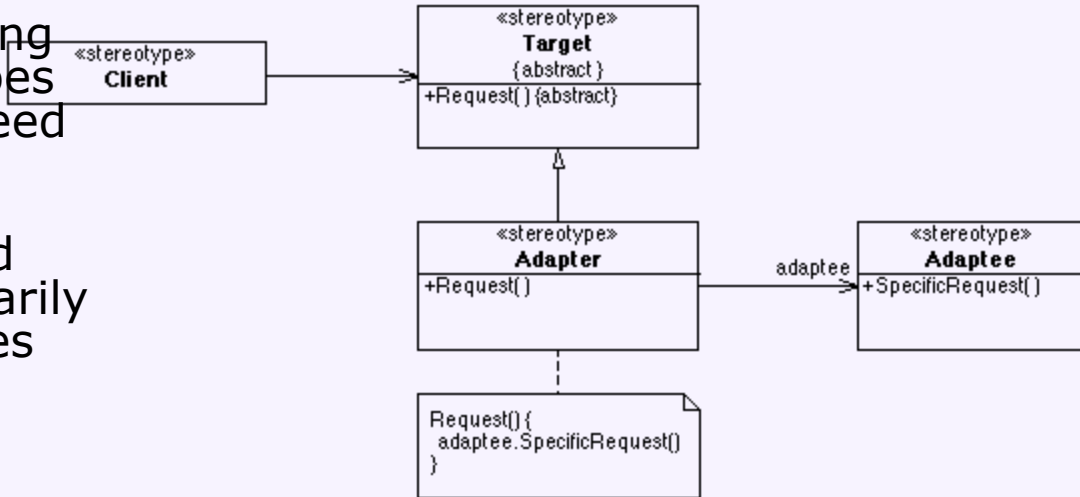

- Consequences

- Exposes the functionality of an object in another form
- Unifies the interfaces of multiple incompatible adaptee objects
- Lets a single adapter work with multiple adaptees in a hierarchy

Back to Design Goals

- **Explicit Interfaces**
 - Façade – a new interface for a library
 - Adapter – design application to a common interface, adapt other libraries to that
- **Modular Decomposition**
 - Separate Client from Subsystem/Adaptee, can be designed and changed (somewhat) independently
- **Modular Continuity, Information Hiding**
 - Changes in subsystem/adaptee do not affect clients
- ...

Façade vs. Adapter

- Motivation
 - Façade: simplify the interface
 - Adapter: match an existing interface
- Adapter: interface is given
 - Not typically true in Façade
- Adapter: polymorphic
 - Dispatch dynamically to multiple implementations
 - Façade: typically choose the implementation statically

Scenario

- Context: eCommerce application
 - Cart object holds Items
- Problem: how to compute taxes?
 - State sales tax
 - Local sales tax
 - Differing exemptions
 - ...
- How can we make the taxation algorithm easy to change?

Behavioral: Strategy

- Applicability
 - Many classes differ in only their behavior
 - Client needs different variants of an algorithm
- Consequences
 - Code is more extensible with new strategies
 - Compare to conditionals
 - Separates algorithm from context
 - each can vary independently
 - Adds objects and dynamism
 - code harder to understand
 - Common strategy interface
 - may not be needed for all Strategy implementations – may be extra overhead

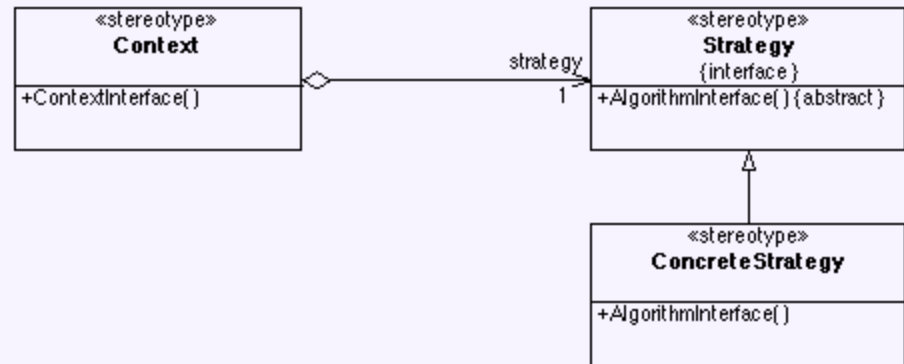

Back to Design Goals

- Explicit Interfaces
 - Strategy: the algorithm interface
- Modular (De)composability, Information hiding
 - Separate context from algorithm
- Modular Continuity
 - Algorithm changes -> add new strategy without changing the context
- ...
- Side note: how do you implement the Strategy pattern in functional languages?

Behavioral: Template Method

- **Applicability**

- When an algorithm consists of varying and invariant parts that must be customized
- When common behavior in subclasses should be factored and localized to avoid code duplication
- To control subclass extensions to specific operations

- **Consequences**

- Code reuse
- Inverted “Hollywood” control: don’t call us, we’ll call you
- Ensures the invariant parts of the algorithm are not changed by subclasses

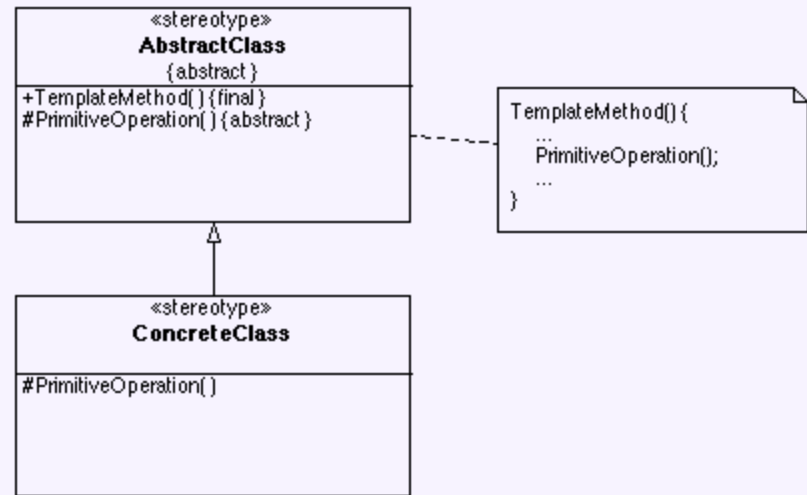

Creational: Factory Method

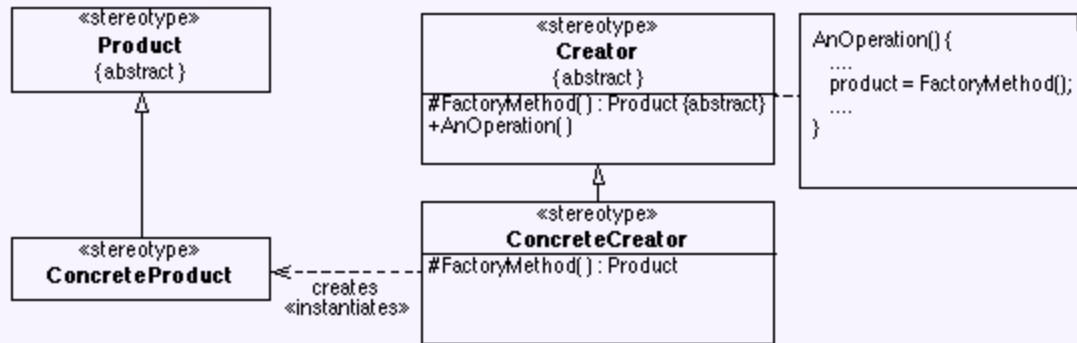

• Applicability

- A class can't anticipate the class of objects it must create
- A class wants its subclasses to specify the objects it creates

• Consequences

- Provides hooks for subclasses to customize creation behavior
- Connects parallel class hierarchies

Scenario

- Context: Window library
 - Multiple kinds of windows
 - Multiple implementation families (by library, OS, etc.)
 - Bridge pattern
- Problem: how to create the implementation objects?
 - Avoid tying window interface to particular back ends
 - Back ends must work together (no mixing Swing and SWT components)

Creational: Abstract factory

- Applicability
 - System should be independent of product creation
 - Want to configure with multiple families of products
 - Want to ensure that a product family is used together
- Consequences
 - Isolates concrete classes
 - Makes it easy to change product families
 - Helps ensure consistent use of family
 - Hard to support new kinds of products

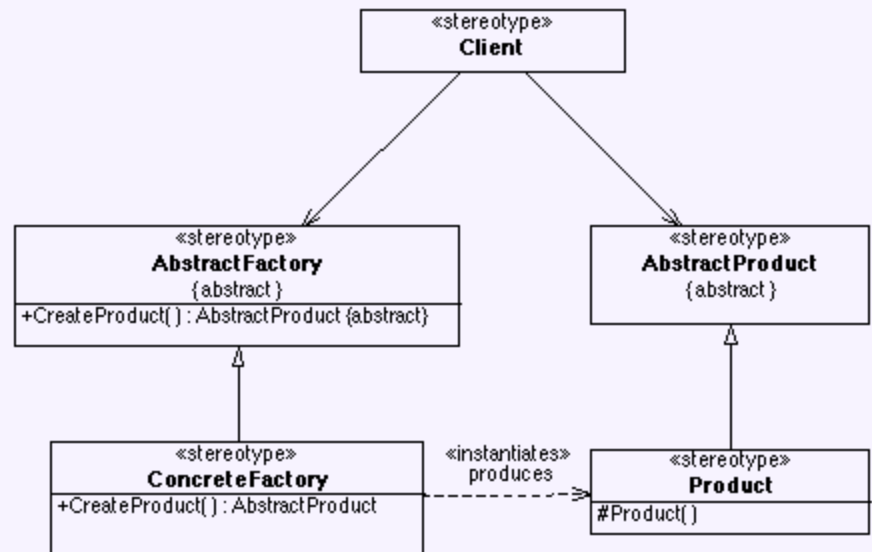

Scenario

- Shape graphics library
 - rectangles, circles, squares
 - extensible to more shapes

- Need flexible implementation
 - Java Swing
 - Eclipse SWT
 - Printing libraries, etc.

- How can we allow both:
 - extension with new shapes
 - adaptation to new back ends?

Structural: Decorator

- **Applicability**

- To add responsibilities to individual objects dynamically and transparently
- For responsibilities that can be withdrawn
- When extension by subclassing is impractical

- **Consequences**

- More flexible than static inheritance
- Avoids monolithic classes
- Breaks object identity
- Lots of little objects

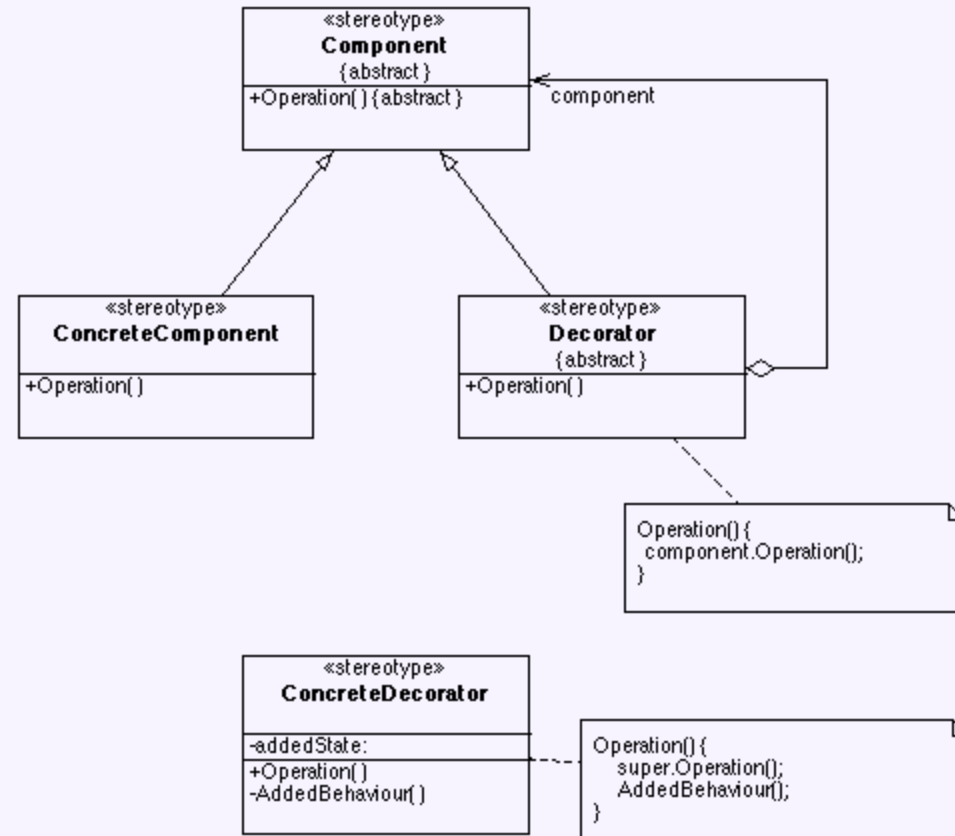

Behavioral: Observer

- **Applicability**
 - When an abstraction has two aspects, one dependent on the other, and you want to reuse each
 - When change to one object requires changing others, and you don't know how many objects need to be changed
 - When an object should be able to notify others without knowing who they are
- **Consequences**
 - Loose coupling between subject and observer, enhancing reuse
 - Support for broadcast communication
 - Notification can lead to further updates, causing a cascade effect

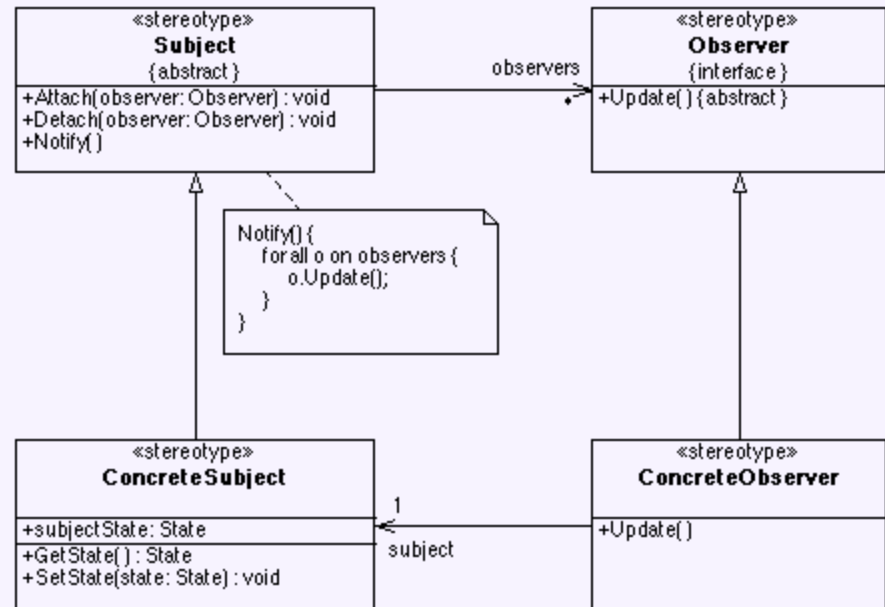

Behavioral: Command

- **Applicability**

- Parameterize objects by an action to perform
- Specify, queue and execute requests at different times
- Support undo
- Support logging changes that can be reapplied after a crash
- Structure a system around high-level operations built out of primitives

- **Consequences**

- Decouples the object that invokes the operation from the one that performs it
- Since commands are objects they can be explicitly manipulated
- Can group commands into composite commands
- Easy to add new commands without changing existing code

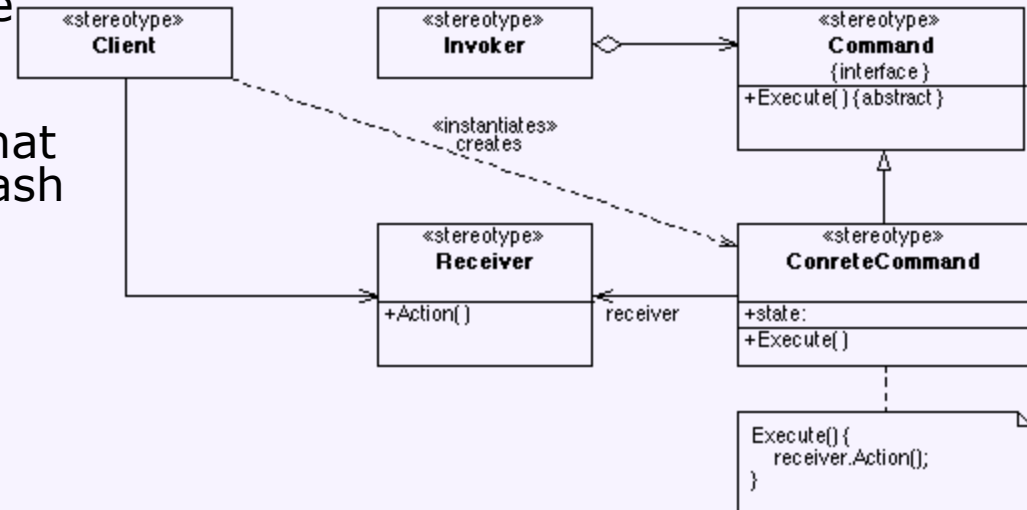

Structural: Bridge

- Applicability
 - Want to define multiple abstractions
 - Need to implement in multiple ways
- Consequences
 - Avoid blow-up in number of classes
 - Decouples abstraction from implementation
 - Choose each separately, even at run time
 - Extend each independently
 - Hide implementation from clients
 - Requires fixed implementation interface

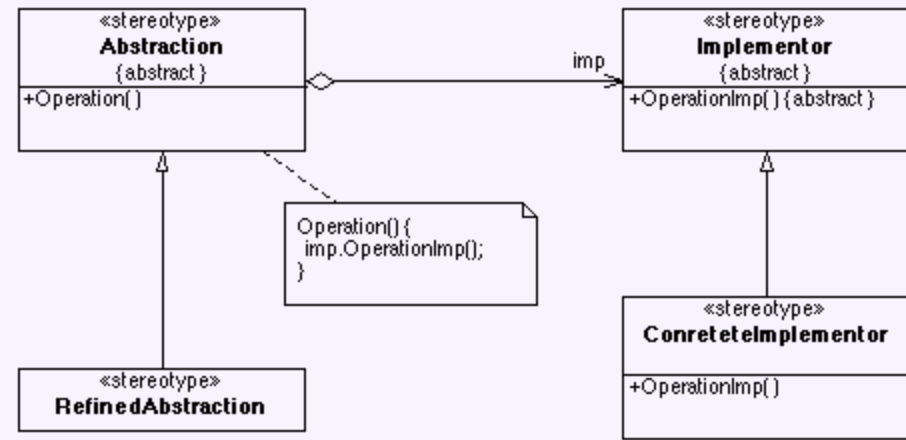

Scenario

- You have global data & operations
 - Must be used consistently within the app
 - Might be changed later
 - Don't want to pass around explicitly
- No good existing place to create and store the object

Creational: Singleton

- Applicability

- There must be exactly one instance of a class
- When it must be accessible to clients from a well-known place
- When the sole instance should be extensible by subclassing, with unmodified clients using the subclass

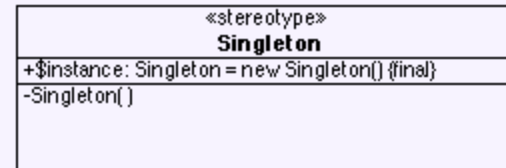

- Consequences

- Controlled access to sole instance
- Reduced name space (vs. global variables)
- Can be refined in subclass or changed to allow multiple instances
- More flexible than class operations
 - Can change later if you need to

- Implementation

- Constructor is protected
- Instance variable is private
- Public operation returns singleton
 - May lazily create singleton

- Subclassing

- Instance() method can look up subclass to create in environment

Structural: Proxy

- Applicability

- Whenever you need a more sophisticated object reference than a simple pointer
 - Local representative for a remote object
 - Create or load expensive object on demand
 - Control access to an object
 - Reference count an object

- Consequences

- Introduces a level of indirection
 - Hides distribution from client
 - Hides optimizations from client
 - Adds housekeeping tasks

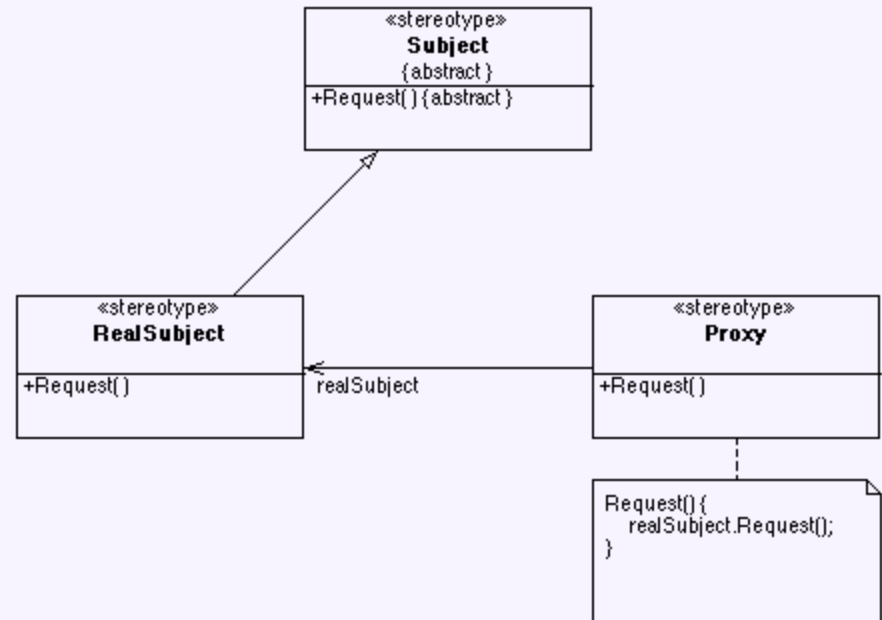

Behavioral: Visitor

- Applicability
 - Structure with many classes
 - Want to perform operations that depend on classes
 - Set of classes is stable
 - Want to define new operations
- Consequences
 - Easy to add new operations
 - Groups related behavior in Visitor
 - Adding new elements is hard
 - Visitor can store state
 - Elements must expose interface

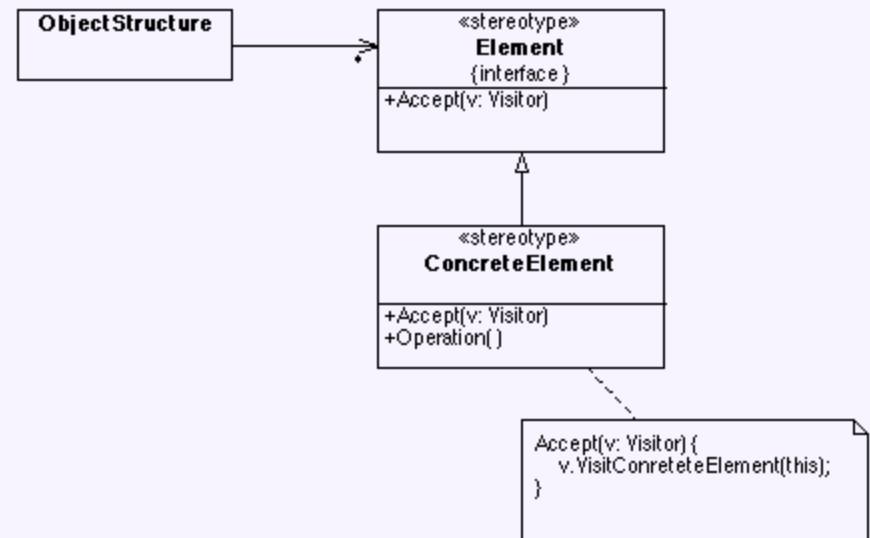
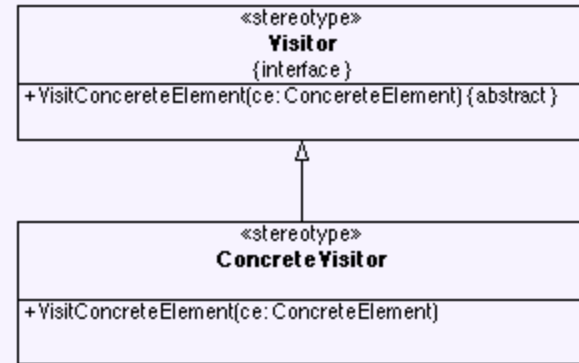

Other GoF Patterns

- **Creational**
 - Builder – separate creation from representation
 - Prototype – create objects by copying
- **Structural**
 - Flyweight – use sharing for fine-grained objects
- **Behavioral**
 - Chain of Responsibility – sequence of objects can respond to a request
 - Interpreter – canonical implementation technique
 - Memento – externalize/restore an object's state
 - Mediator – a set of objects that communicate in well-defined but complex ways
 - State – allow object to alter behavior when state changes