

Hashing



15-111
Data Structures

Ananda Gunawardena

Hashing

Why do we need hashing?



- Many applications deal with lots of data
 - Search engines and web pages
- There are myriad look ups.
- The look ups are time critical.
- Typical data structures like arrays and lists, may not be sufficient to handle efficient lookups
- **In general**: When look-ups need to occur in near **constant time. $O(1)$**

Why do we need hashing?

- Consider the internet(2002 data):
 - By the Internet Software Consortium survey at <http://www.isc.org/> in 2001 there are 125,888,197 internet hosts, and the number is growing by 20% every six month!
 - Using the best possible binary search it takes on average 27 iterations to find an entry.
 - By an survey by NUA at <http://www.nua.ie/> there are 513.41 million users world wide.

Why do we need hashing?



- We need something that can do better than a binary search, $O(\log N)$.
- We want, $O(1)$.

Solution: **Hashing**

In fact hashing is used in:

Web searches

Compilers

Spell checkers

passwords

Databases

Many others

Building an index using HashMaps

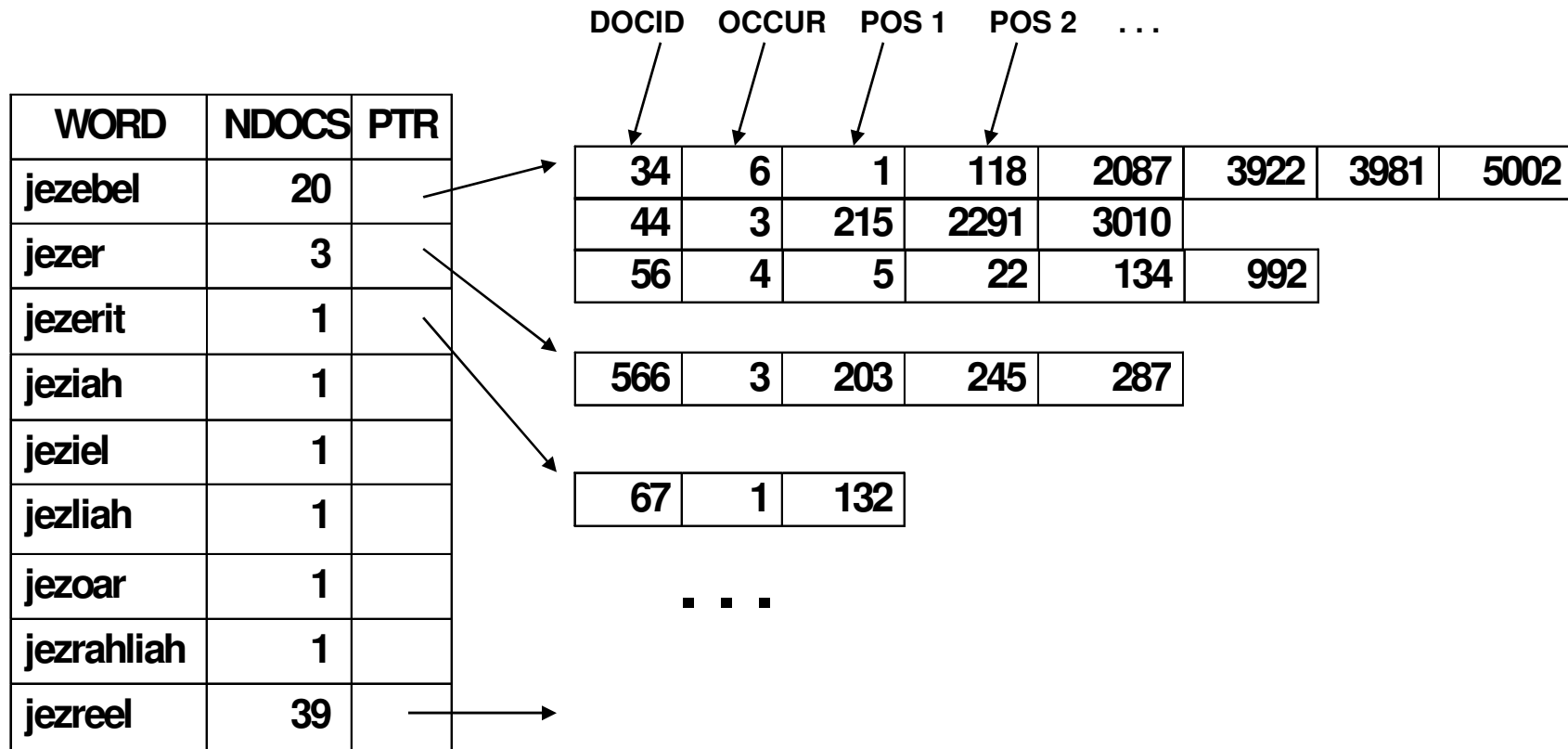

More on this in Graphs...

The concept

- Suppose we need to find a better way to maintain a table (Example: a Dictionary) that is **easy to insert and search in $O(1)$** .

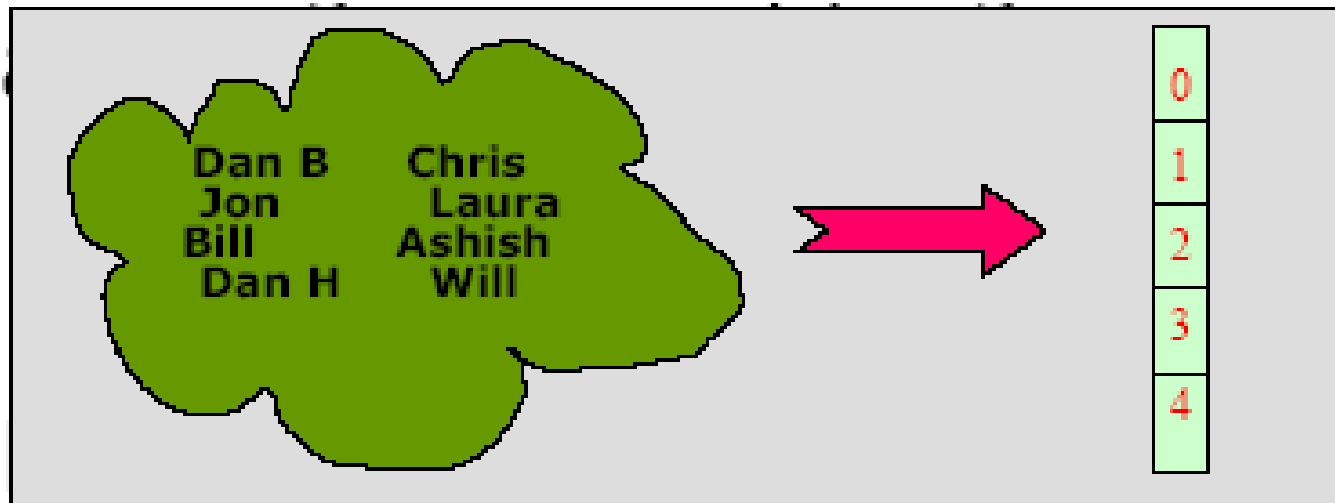

Big Idea in Hashing

- Let $S = \{a_1, a_2, \dots, a_m\}$ be a set of objects that we need to map into a table of size N .
 - Find a function such that $H:S \rightarrow [1\dots n]$
 - Ideally we'd like to have a 1-1 map
 - But it is not easy to find one
 - Also function must be **easy to compute**
 - It is a good idea to pick a **prime** as the table size to have a better distribution of values
- Assume a_i is a 16-bit integer.
 - Of course there is a trivial map $H(a_i) = a_i$
 - But this may not be practical. Why?

Finding a hash Function

- Assume that $N = 5$ and the values we need to insert are: **cab, bea, bad** etc.
- Let $a=0, b=1, c=2$, etc
- Define H such that
 - $H[\text{data}] = (\sum \text{characters}) \text{ Mod } N$
- $H[\text{cab}] = (2+0+1) \text{ Mod } 5 = 3$
- $H[\text{bea}] = (1+4+0) \text{ Mod } 5 = 0$
- $H[\text{bad}] = (1+0+3) \text{ Mod } 5 = 4$

Collisions



- What if the values we need to insert are "abc", "cba", "bca" etc...
 - They all map to the same location based on our map H (obviously H is not a good hash map)
- This is called "Collision"
- When collisions occur, we need to "handle" them
- Collisions can be reduced with a selection of a good hash function

Choosing a Hash Function

- A good hash function must
 - Be easy to compute
 - Avoid collisions
- How do we find a **good** hash function?
- A **bad** hash function
 - Let S be a string and $H(S) = \sum S_i$ where S_i is the i^{th} character of S
 - Why is this bad?

Choosing a Hash Function?

■ Question

- Think of hashing 10000, 5-letter words into a table of size 10000 using the map H defined as follows.
- $H(a_0a_1a_2a_3a_4) = \sum a_i \quad (i=0,1,\dots,4)$
- If we use H, what would be the key distribution like?

Choosing a Hash Function

- Suppose we need to hash a set of strings $S = \{S_i\}$ to a table of size N
- $H(S_i) = (\sum S_i[j].d^j) \bmod N$, where $S_i[j]$ is the j^{th} character of string S_i
 - How expensive is to compute this function?
 - cost with direct calculation
 - Is it always possible to do direct calculation?
 - Is there a cheaper way to calculate this? Hint: use Horner's Rule.

Code



```
public static int hash(String key, int n){  
    int value = 0;  
    for (int i=0; i<key.length(); i++)  
        value = (value*128+ key.charAt(i))%n;  
    return value;  
}
```

- What does this function return if "guna" is hashed into a table of size 101?
- What is the complexity of code in terms of string length?
- What are some of the problems with this function?

Collisions

- Hash functions can be *many-to-1*
 - They can map different search keys to the same hash key.

`hash1(`a`) == 9 == hash1(`w`)`

- Must compare the search key with the record found
 - If the match fails, there is a **collision**

Collision Resolving strategies



- Separate chaining
- Open addressing
 - Linear Probing
 - Quadratic Probing
 - Double Probing
 - *Etc.*

Separate Chaining

- Collisions can be resolved by creating a list of keys that map to the same value

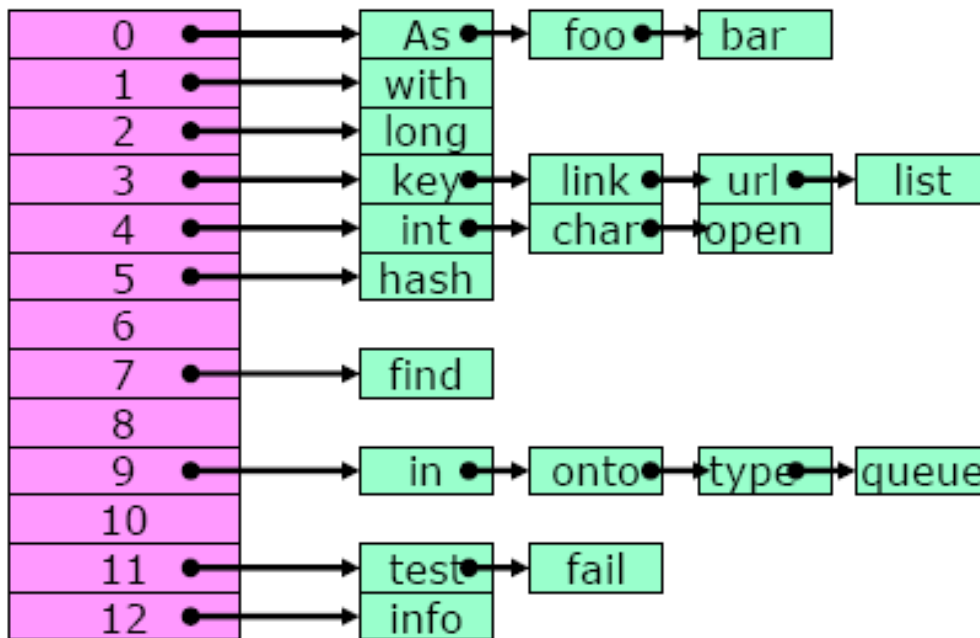

Separate Chaining

- Use an array of linked lists
 - `LinkedList[] Table;`
 - `Table = new LinkedList(N)`, where N is the table size
- Define **Load Factor** of Table as
 - $\lambda = \text{number of keys} / \text{size of the table}$
(λ can be more than 1)
- Still need a good hash function to distribute keys evenly
 - For search and updates

Linear Probing

- **The idea:**

- Table remains a simple array of size N
- On **insert(x)**, compute $f(x) \bmod N$, if the cell is full, find another by sequentially searching for the next available slot
 - Go to $f(x)+1$, $f(x)+2$ etc..
- On **find(x)**, compute $f(x) \bmod N$, if the cell doesn't match, look elsewhere.
- Linear probing function can be given by
 - $h(x, i) = (f(x) + i) \bmod N$ ($i=1,2,\dots$)

Figure 20.4

Linear probing
hash table after
each insertion

hash (89, 10) = 9
hash (18, 10) = 8
hash (49, 10) = 9
hash (58, 10) = 8
hash (9, 10) = 9

	<i>After insert 89</i>	<i>After insert 18</i>	<i>After insert 49</i>	<i>After insert 58</i>	<i>After insert 9</i>
0			49	49	49
1				58	58
2					9
3					
4					
5					
6					
7					
8		18	18	18	18
9	89	89	89	89	89

Linear Probing Example

- Consider $H(\text{key}) = \text{key} \bmod 6$ (assume $N=6$)
- $H(11)=5, H(10)=4, H(17)=5, H(16)=4, H(23)=5$
- Draw the Hash table

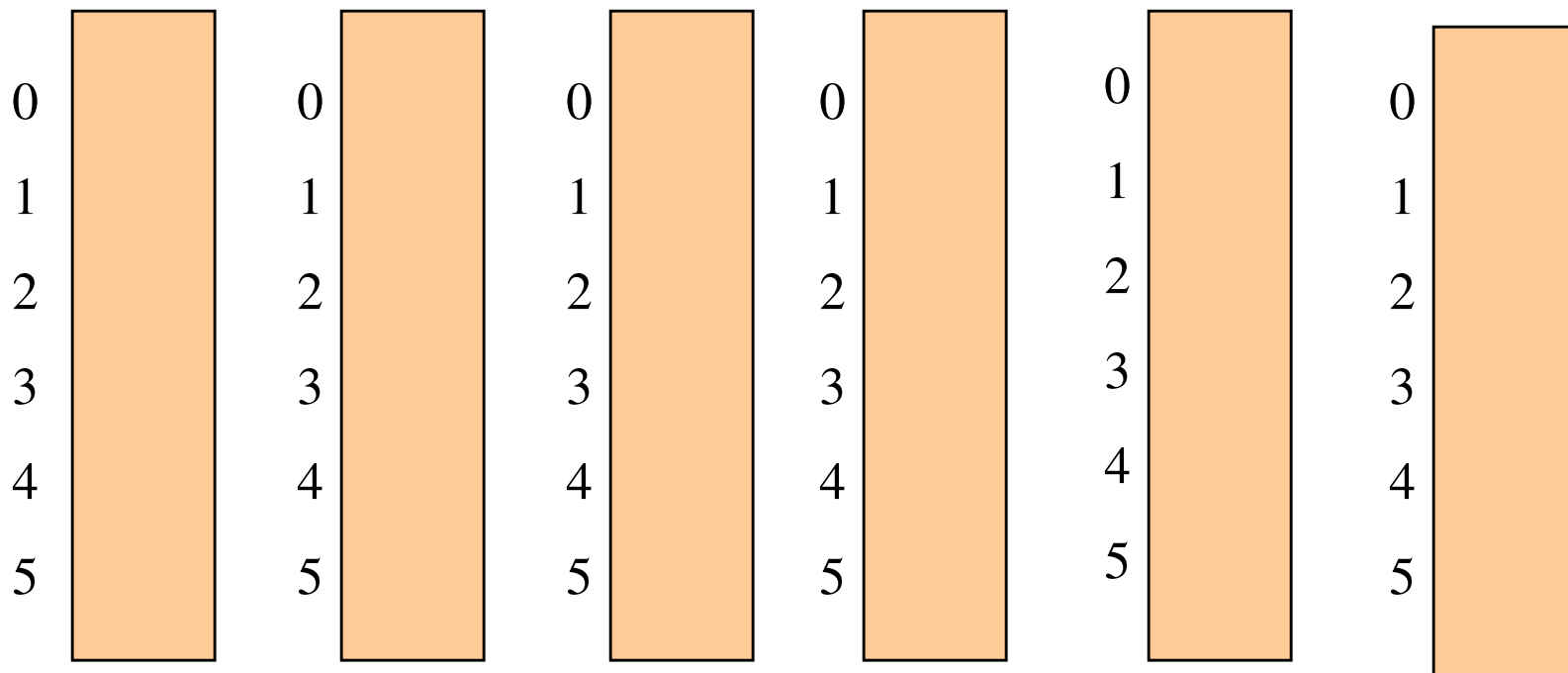

Clustering Problem

- Clustering is a significant problem in linear probing. Why?
- Illustration of primary clustering in linear probing (b) versus no clustering (a) and the less significant secondary clustering in quadratic probing (c). Long lines represent occupied cells, and the load factor is 0.7.



Linear Probing



- How about deleting items from Hash table?
 - Item in a hash table **connects** to others in the table(eg: BST).
 - Deleting items will affect finding the others
 - “**Lazy Delete**” – Just mark the items as inactive rather than removing it.

Lazy Delete

- **Naïve** removal can leave gaps!

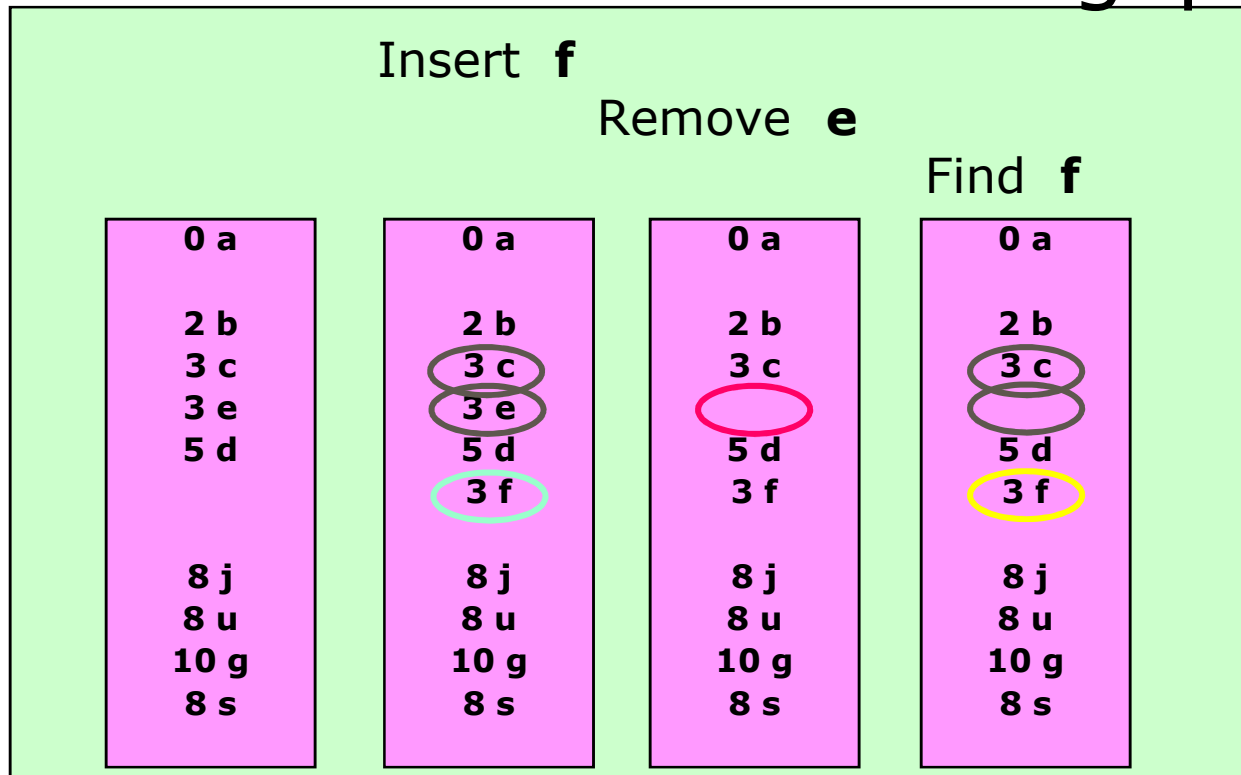

"3 f" means *search key f and hash key 3*

Lazy Delete

- **Clever** removal

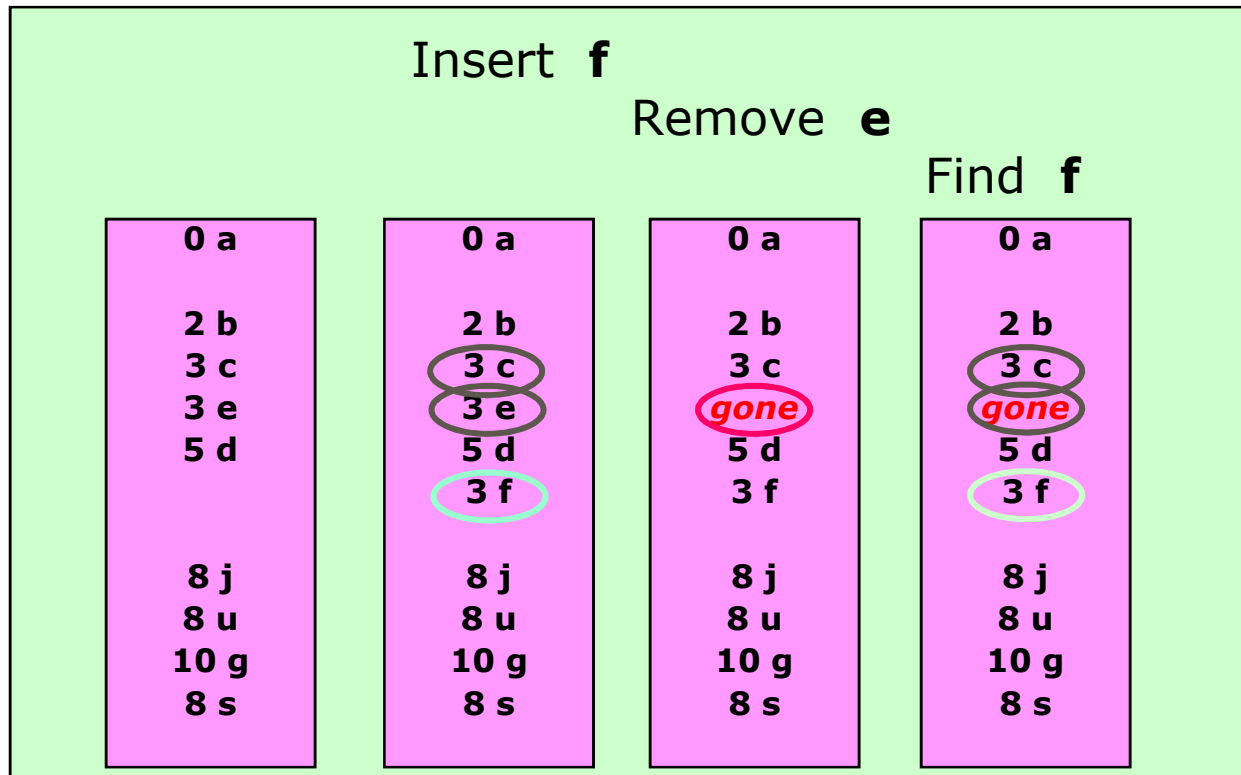

"3 f" means search key f and hash key 3

Load Factor (open addressing)

- **definition:** The *load factor* λ of a probing hash table is the fraction of the table that is full. The load factor ranges from 0 (empty) to 1 (completely full).
- It is better to keep the **load factor** under 0.7
- **Double** the table size and **rehash** if load factor gets high
- Cost of Hash function $f(x)$ must be minimized
- When collisions occur, linear probing can always find an empty cell
 - But clustering can be a problem



Quadratic Probing

Quadratic probing

- Another open addressing method
- Resolve collisions by examining certain cells (1,4,9,...) away from the original probe point
- Collision policy:
 - Define $h_0(k), h_1(k), h_2(k), h_3(k), \dots$
where $h_i(k) = (\text{hash}(k) + i^2) \bmod \text{size}$
- Caveat:
 - May not find a vacant cell!
 - Table must be less than half full ($\lambda < 1/2$)
 - (Linear probing always finds a cell.)

Quadratic probing

- Another issue

- Suppose the table size is 16.

- Probe offsets that will be tried:

1	mod 16	=	1
4	mod 16	=	4
9	mod 16	=	9
16	mod 16	=	0
25	mod 16	=	9
36	mod 16	=	4
49	mod 16	=	1
64	mod 16	=	0
81	mod 16	=	1

only four different values!

Figure 20.6

A quadratic probing hash table after each insertion (note that the table size was poorly chosen because it is not a prime number).

$$\begin{aligned}\text{hash} (89, 10) &= 9 \\ \text{hash} (18, 10) &= 8 \\ \text{hash} (49, 10) &= 9 \\ \text{hash} (58, 10) &= 8 \\ \text{hash} (9, 10) &= 9\end{aligned}$$

	<i>After insert 89</i>	<i>After insert 18</i>	<i>After insert 49</i>	<i>After insert 58</i>	<i>After insert 9</i>
0			49	49	49
1					
2				58	58
3					9
4					
5					
6					
7					
8		18	18	18	18
9	89	89	89	89	89