

**15-410**

*“...The mysterious TLB...”*

Virtual Memory #2  
Sep. 25, 2009

**Dave Eckhardt**

**Garth Gibson**

# Last Time

**Mapping problem: logical vs. physical addresses**

**Contiguous memory mapping (base, limit)**

**Swapping –taking turns in memory**

**Paging**

- Array mapping page numbers to frame numbers
- Observation: typical table is *sparsely occupied*
- Response: some sparse data structure (e.g., 2-level array)

# Swapping

## Multiple user processes

- Sum of memory demands > system memory
- Goal: Allow *each process* 100% of system memory

## Take turns

- Temporarily evict process(es) to disk
- “Swap daemon” shuffles process in & out
- Can take *seconds* per process
- Creates *external fragmentation* problem

# External Fragmentation (“Holes”)

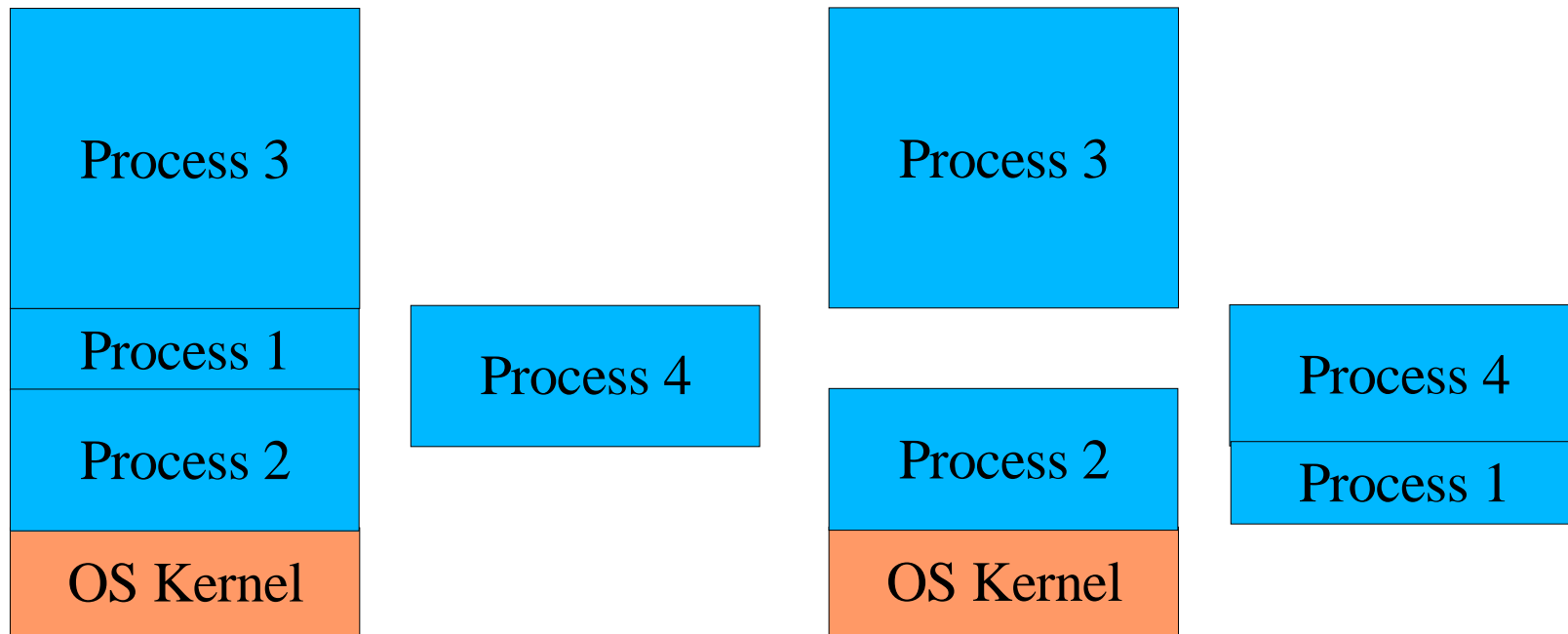

# Benefits of Paging

## Process growth problem

- Any process can use any free frame for any purpose

## Fragmentation compaction problem

- Process doesn't need to be contiguous

## Long delay to swap a whole process

- Swap *part* of the process instead!

# Partial Residence

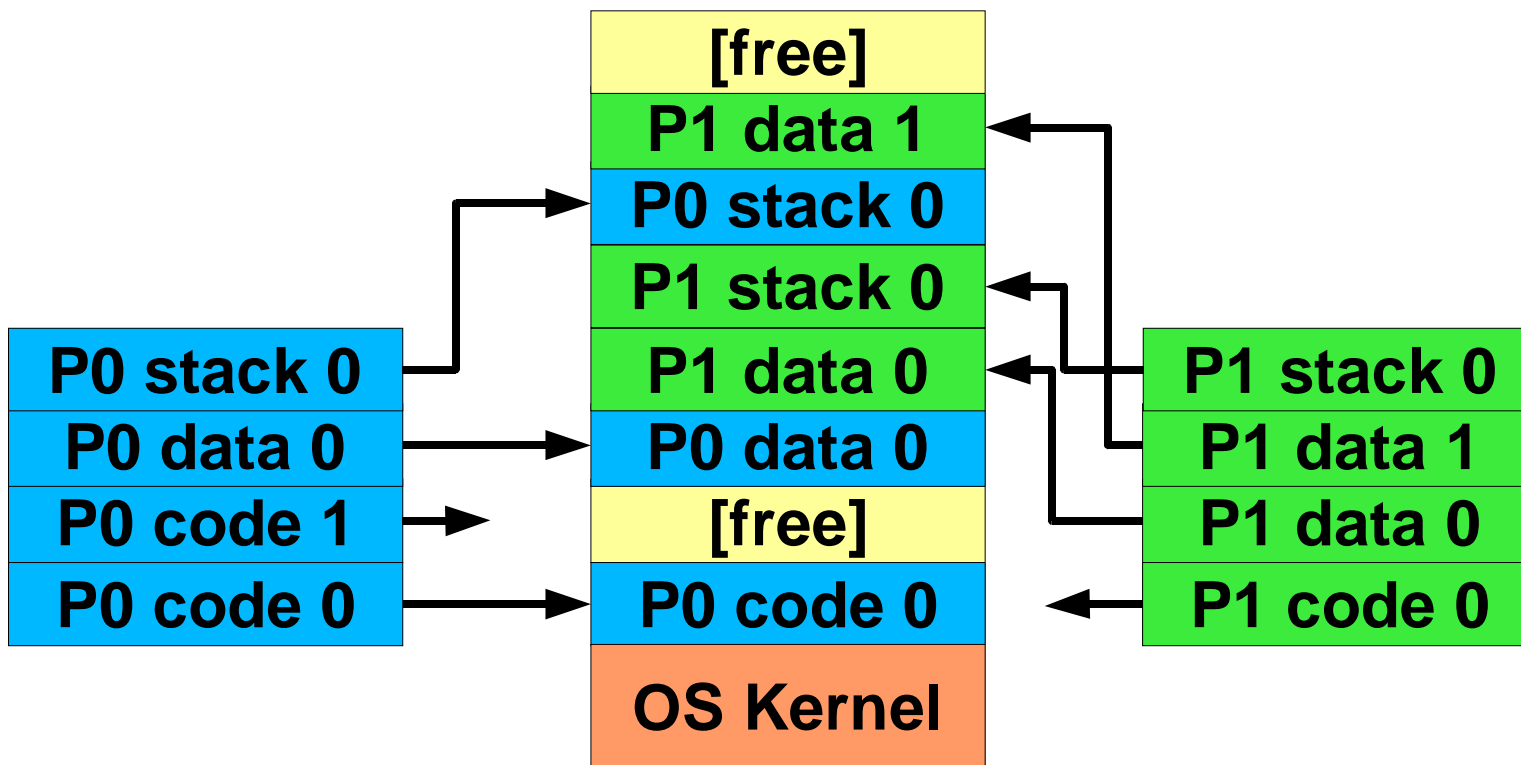

# Page Table Entry (PTE) flags

## Protection bits –set by OS

- Read/write/execute

## Valid/Present bit –set by OS

- Frame pointer is valid, no need to fault

## Dirty bit

- Hardware sets 0  $\Rightarrow$  1 when data stored into page
- OS sets 1  $\Rightarrow$  0 when page has been written to disk

## Reference bit

- Hardware sets 0  $\Rightarrow$  1 on any data access to page
- OS uses for page eviction (later)

# Outline

**The mysterious TLB**

**Partial memory residence (demand paging) in action**

**The task of the page fault handler**

# Double Trouble? Triple Trouble?

**Program requests memory access**

**Processor makes *two* memory accesses!**

- Split address into page number, intra-page offset
- Add to page table base register
- *Fetch page table entry (PTE) from memory*
- Add frame address, intra-page offset
- *Fetch data from memory*

# Double Trouble? Triple Trouble?

**Program requests memory access**

**Processor makes *two* memory accesses!**

- Split address into page number, intra-page offset
- Add to page table base register
- *Fetch page table entry (PTE) from memory*
- Add frame address, intra-page offset
- *Fetch data from memory*

**Can be worse than that...**

- x86 Page-Directory/Page-Table
  - *Three* physical accesses per virtual access!
- x86-64 has a *four-level* page-mapping system

# Translation Lookaside Buffer (TLB)

## Problem

- Cannot afford double/triple/... memory latency

## Observation - “locality of reference”

- Program often accesses “nearby” memory
- Next instruction often on same page as current instruction
- Next byte of string often on same page as current byte
- (“Array good, linked list bad”)

## Solution

- Page-map hardware caches virtual-to-physical *mappings*
  - Small, fast on-chip memory
  - “Free” in comparison to slow off-chip memory

# Simplest Possible TLB

## Approach

- Remember the most-recent virtual-to-physical translation
  - (obtained from, e.g., Page Directory + Page Table)
- See if next memory access is to same page
  - If so, skip PD/PT memory traffic; use same frame
  - 3X speedup, cost is two 20-bit registers
    - » “Great work if you can get it”

# Simplest Possible TLB

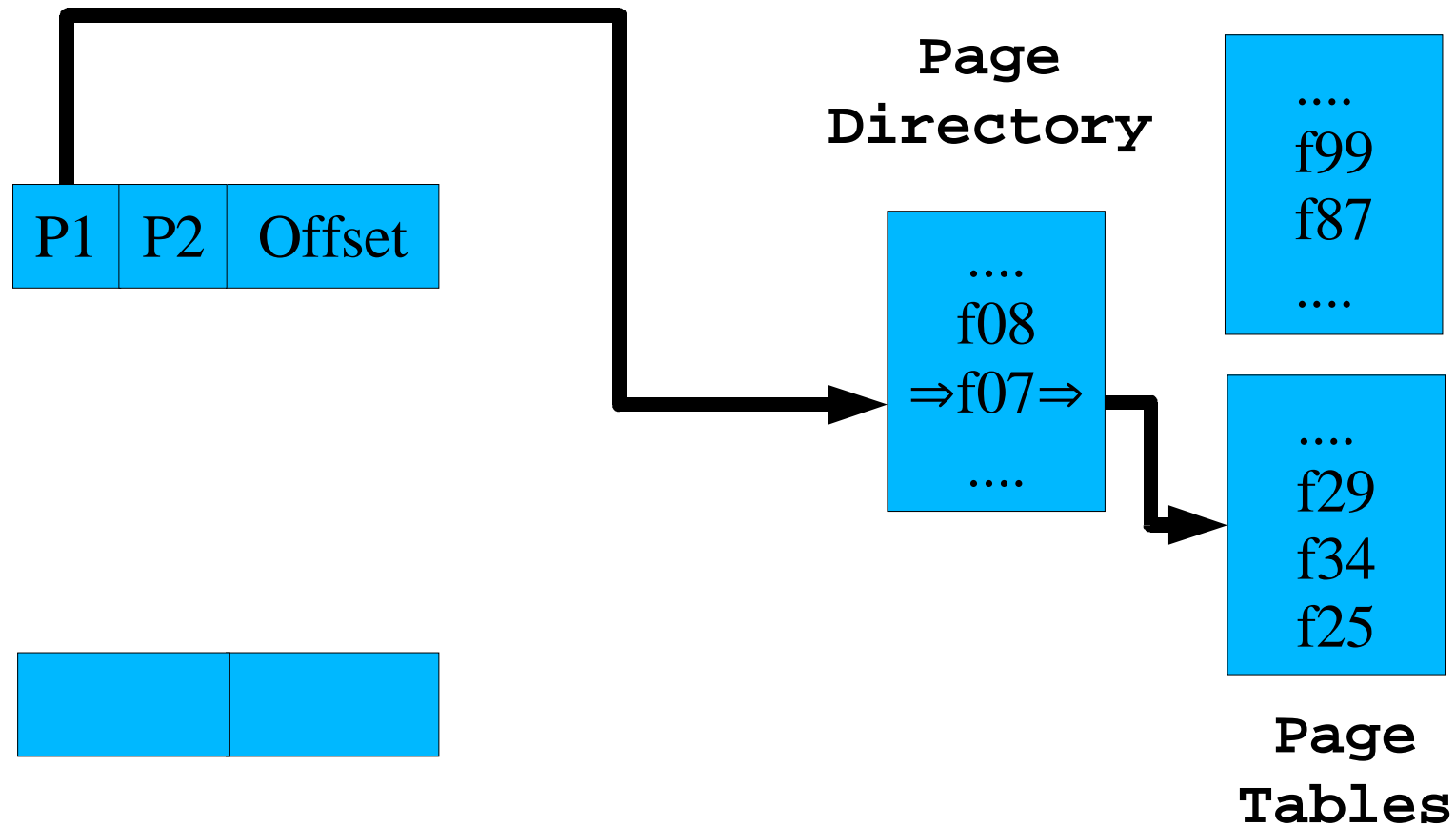

# Simplest Possible TLB

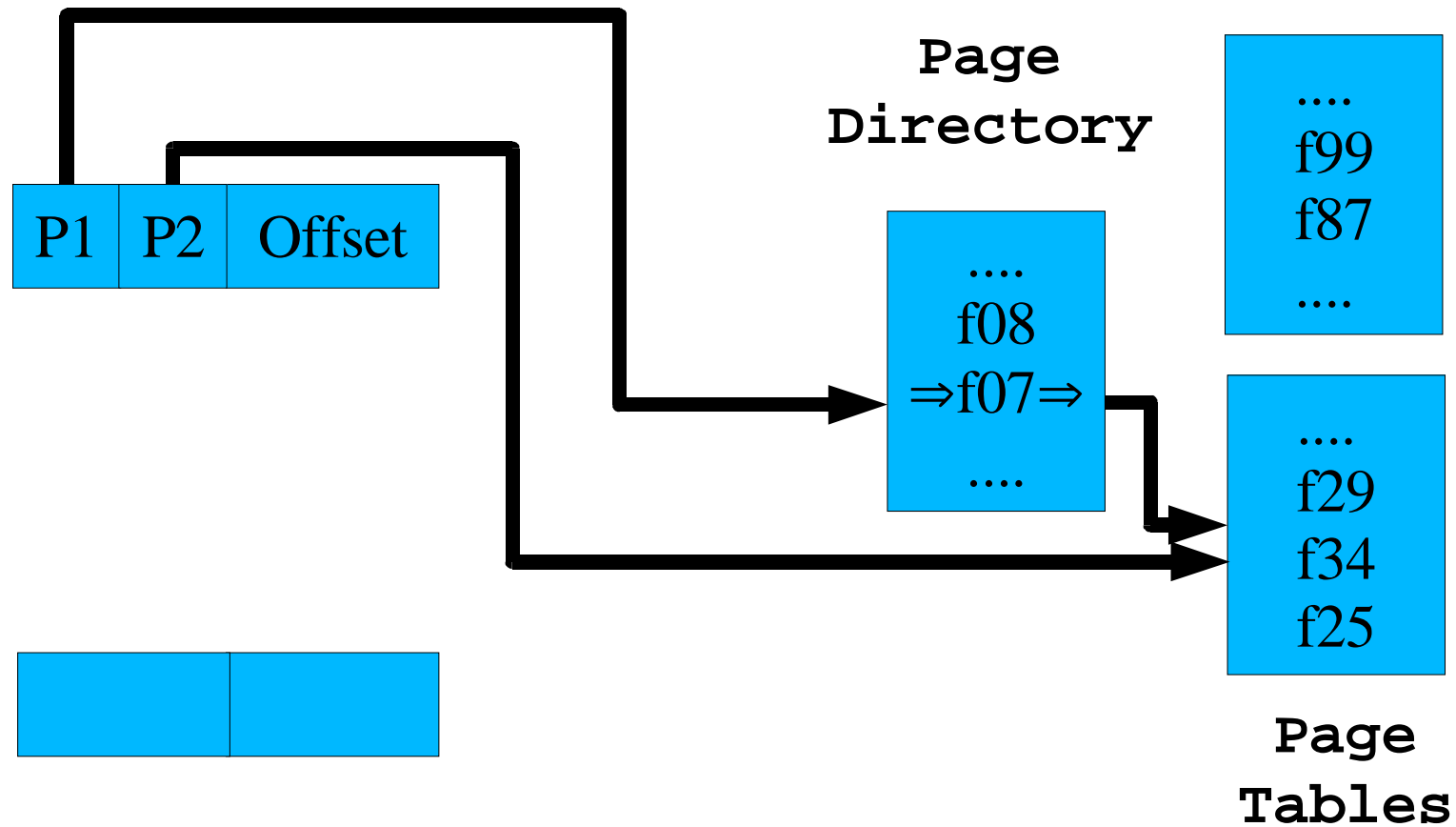

# Simplest Possible TLB

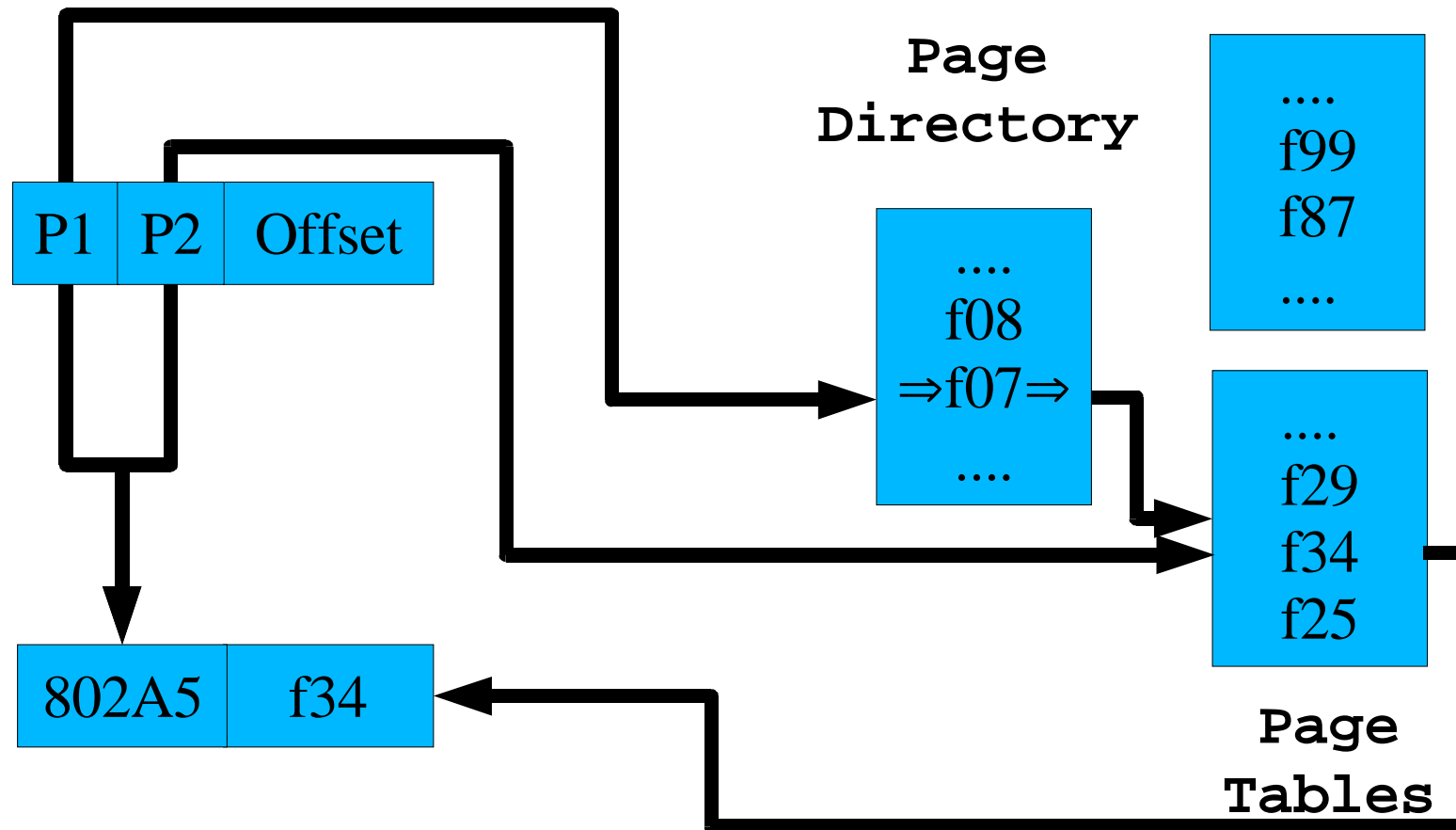

# TLB "Hit"

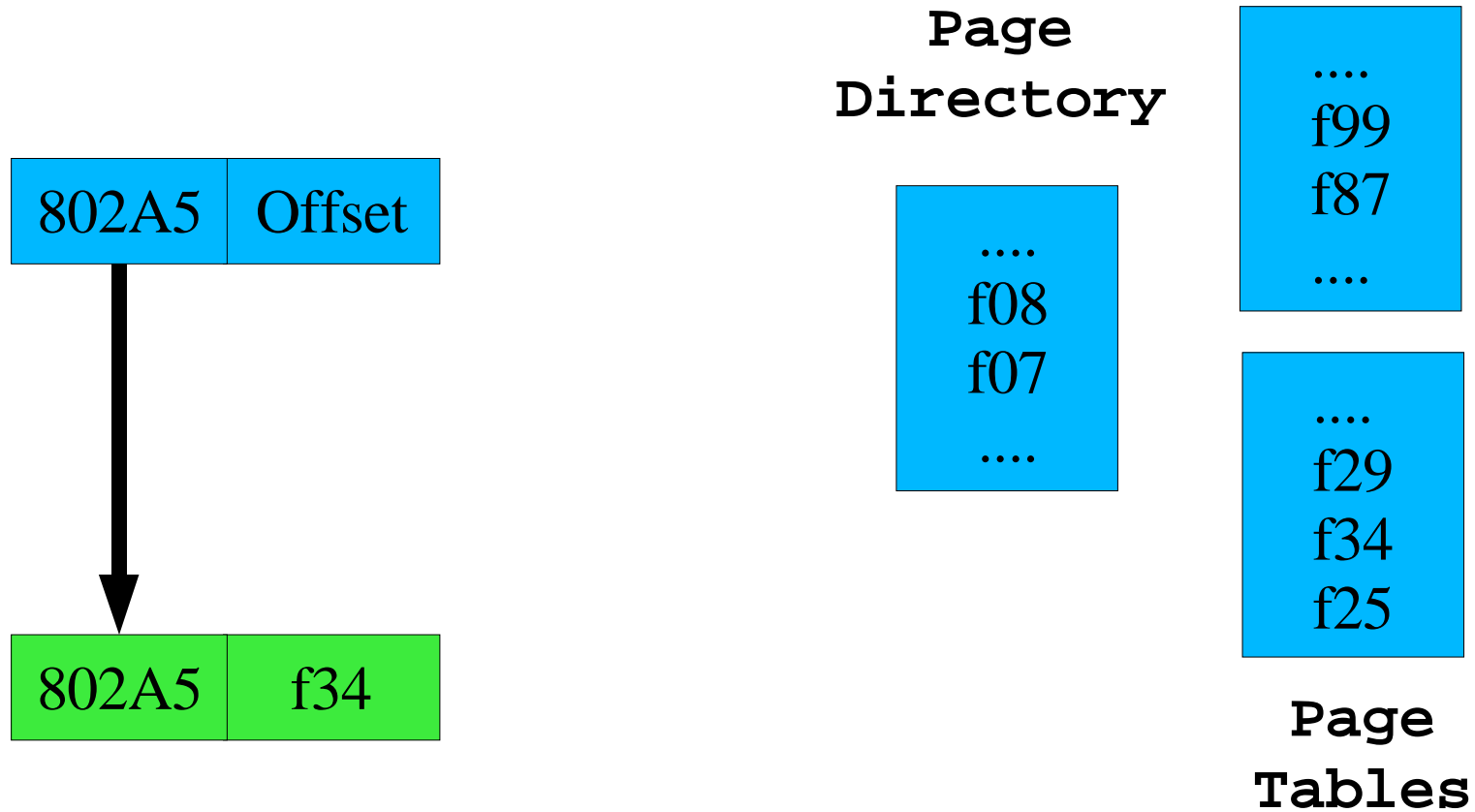

# TLB "Miss"

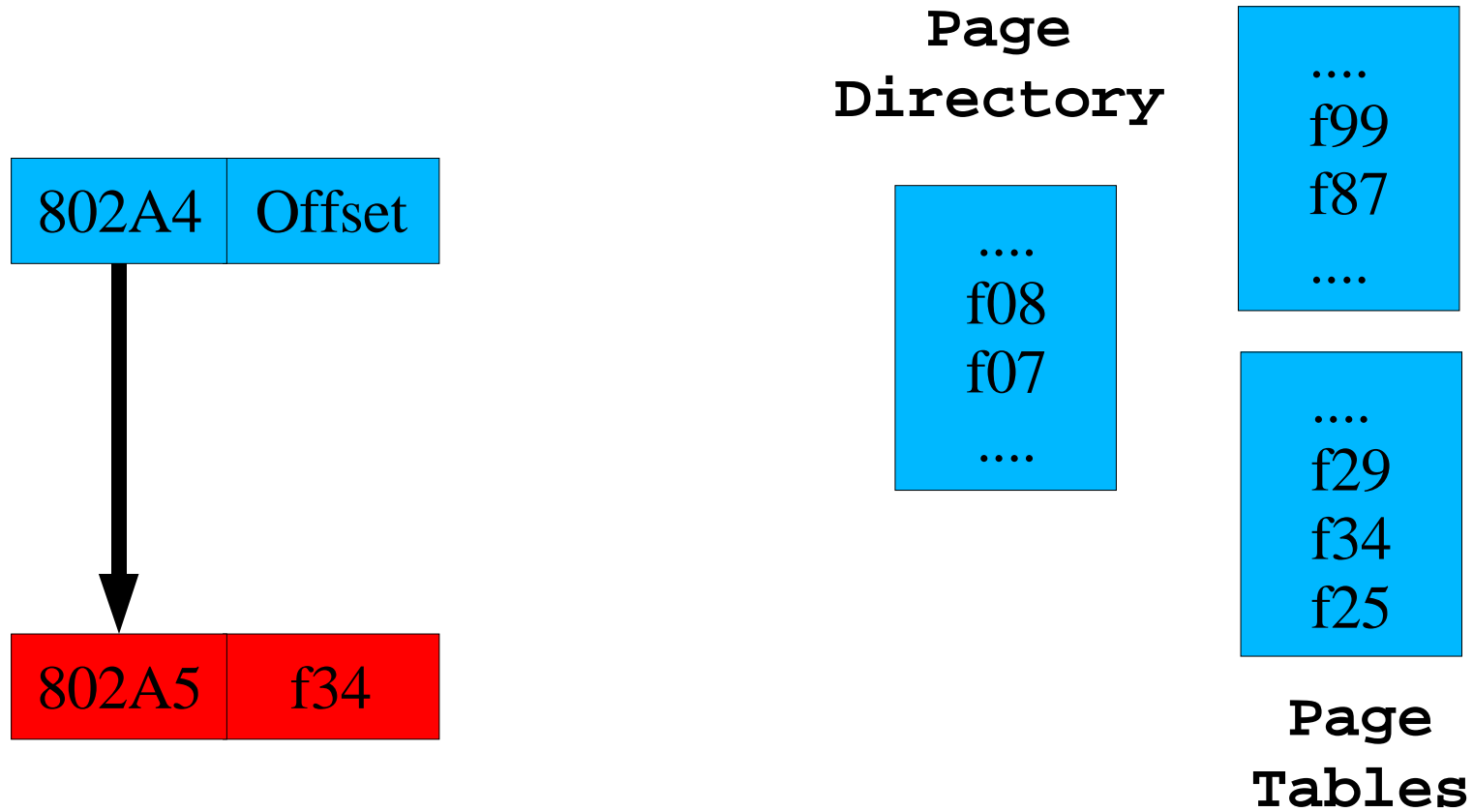

# TLB "Refill"

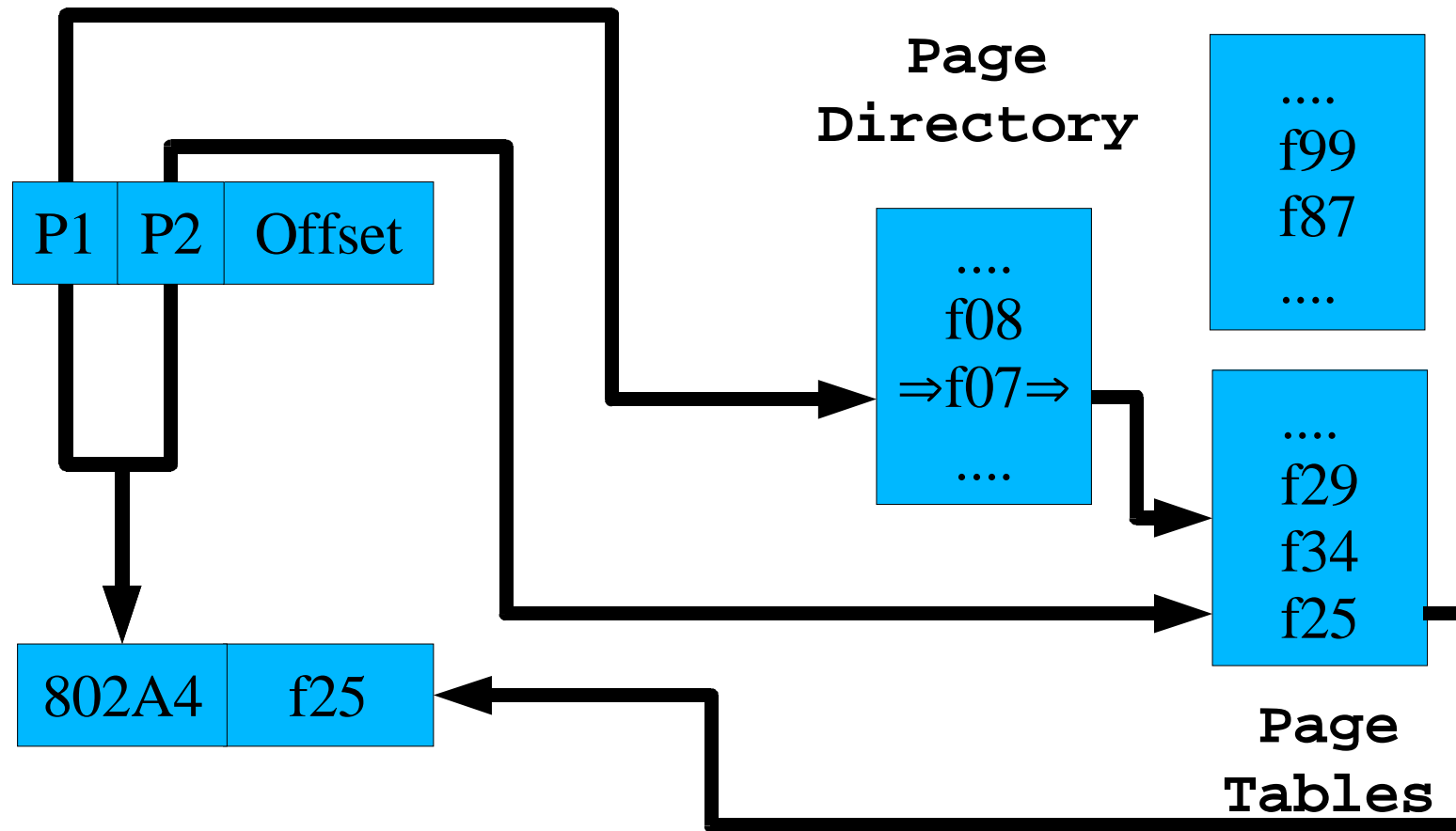

# Simplest Possible TLB

**Can you think of a “pathological” instruction?**

- **What would it take to “break” a 1-entry TLB?**

**How many TLB entries do we need, anyway?**

# TLB vs. Context Switch

## After we've been running a while...

- ...the TLB is “hot” - full of page ⇒ frame translations

## Interrupt!

- Some device is done...
- ...should switch to some other task...
- ...what are the parts of context switch, again?
  - General-purpose registers
  - ...?

# TLB vs. Context Switch

## After we've been running a while...

- ...the TLB is “hot” - full of page ⇒ frame translations

## Interrupt!

- Some device is done...
- ...should switch to some other task...
- ...what are the parts of context switch, again?
  - General-purpose registers
  - Page Table Base Register
  - ...?

# TLB vs. Context Switch

## After we've been running a while...

- ...the TLB is “hot” - full of page ⇒ frame translations

## Interrupt!

- Some device is done...
- ...should switch to some other task...
- ...what are the parts of context switch, again?
  - General-purpose registers
  - Page Table Base Register
  - *Entire contents of TLB!!*
    - » (why?)

# x86 TLB Flush

## 1. Declare new page directory (set %cr3)

- Clears every entry in TLB (whoosh!)
  - Footnote: doesn't clear “global” pages...
    - » Which pages might be “global”?

## 2. INVLPG instruction

- Invalidates TLB entry of one specific page
- Is that more efficient or less?

# x86 Type Theory –Final Version

**Instruction  $\Rightarrow$  segment selector**

- [PUSHL specifies selector in %SS]

**Process  $\Rightarrow$  (selector  $\Rightarrow$  (base,limit) )**

- [Global,Local Descriptor Tables]

**Segment base, address  $\Rightarrow$  linear address**

*TLB: linear address  $\Rightarrow$  physical address, or...*

**Process  $\Rightarrow$  (linear address high  $\Rightarrow$  page table)**

**Page Table: linear address middle  $\Rightarrow$  frame address**

**Memory: frame address, offset  $\Rightarrow$  ...**

# Is there another way?

## That seems *really complicated*

- Is that hardware monster really optimal for every OS and program mix?
- “The only way to win is not to play?”

## Is there another way?

- Could we have *no* page tables?
- How would the hardware map virtual to physical???

# Software-loaded TLBs

## Reasoning

- We *need* a TLB “for performance reasons”
- OS defines each process's memory structure
  - Which memory regions, permissions
  - *Lots* of processes share frames of /bin/bash!
- Hardware page-mapping unit imposes its own ideas
- Why impose a semantic middle-man?

## Approach

- OS knows all mappings for an address space
- TLB contains a subset of them
- TLB miss generates a special trap
- OS *quickly* fills in correct  $v \Rightarrow p$  mapping

# Software TLB features

## Mapping entries can be computed many ways

- Imagine a system with one process memory size
  - TLB miss becomes a matter of arithmetic

## Mapping entries can be “locked” in TLB

- Good idea to lock the TLB-miss handler's TLB entry...
- Great for real-time systems

## Further reading

- [http://yarchive.net/comp/software\\_tlb.html](http://yarchive.net/comp/software_tlb.html)

## Software TLBs

- PowerPC 603, 400-series (but NOT 7xx/9xx, Cell)
- MIPS, some SPARC

# TLB vs. Project 3

## x86 has a nice, automatic TLB

- Hardware page-mapper fills it for you
- Activating new page directory flushes TLB automatically
- What could be easier?

## It's not *totally* automatic

- Something “natural” in your kernel may confuse it...

## TLB debugging in Simics

- logical-to-physical (l2p) command
- `cpu0_tlb.info`, `cpu0_tlb.status`
  - More bits “trying to tell you something”
- [INVLPG issues with Simics 1. Simics 2, 3 seem ok]

# Partial Memory Residence

## Error-handling code not used by every run

- No need for it to occupy memory for entire duration...

## Tables may be allocated larger than used

```
player players[MAX_PLAYERS];
```

## Computer can run *very* large programs

- Much larger than physical memory
- As long as “active” footprint fits in RAM
- Swapping can't do this

## Programs can launch faster

- Needn't load whole program before running

# “Virtual Memory Approach”

## Use RAM frames as a cache for the set of all pages

- Some pages are fast to access (in a RAM frame)
- Some pages are slow to access (in a disk “frame”)

## Page tables indicate which pages are “resident”

- Non-resident pages are missing from the TLB
  - And have “present=0” in page table entry, if we have a hardware page-mapping unit
- Access to a non-resident page generates a *page fault*
  - Hardware invokes page-fault exception handler

## Hopefully “most” references hit in the RAM cache

# Page fault –Reasons, Responses

**Address is invalid/illegal –deliver *software exception***

- Unix –SIGSEGV
- Mach –deliver message to thread's exception port
- 15-410 –kill thread

**Process is growing stack –give it a new frame**

**“Cache misses” - fetch from disk**

- Where on disk, exactly?

# Satisfying Page Faults

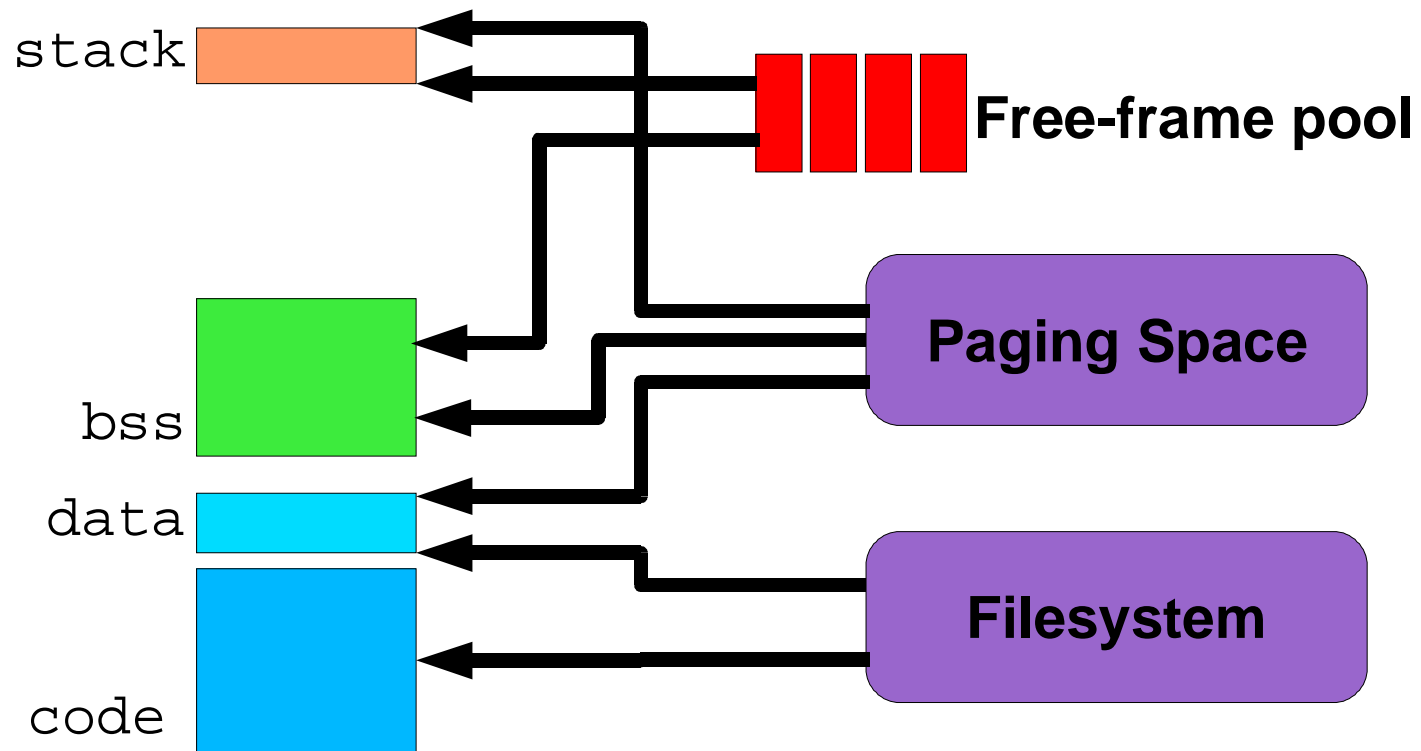

# Page fault story - 1

## Process issues memory reference

- TLB: miss
- (PT: “not present”)

## *Trap* to OS kernel!

- Processor dumps trap frame onto kernel stack (x86)
- Transfers via “page fault” interrupt descriptor table entry
- Runs trap handler

# Page fault story –2

## Classify fault address

- Illegal address ⇒ deliver an ouch, else...

## Code/rodata region of executable?

- Determine which sector of executable file
- Launch read() from file into an unused frame

## Previously resident r/w data, paged out

- “somewhere on the paging partition”
- Queue disk read into an unused frame

## First use of bss/stack page

- Allocate a frame full of zeroes, insert into PT

# Page fault story –3

## Block the process (for most cases)

- Switch to running another

## Handle I/O-complete interrupt

- Fill in PTE (present = 1)
- Mark process runnable

## Restore registers, switch page table

- Faulting instruction re-started transparently
- *Single instruction may fault more than once!*

# Memory Regions vs. Page Tables

## What's a poor page fault handler to do?

- Kill process?
- Copy page, mark read-write?
- Fetch page from file? Which? Where?

## Page table not a good data structure

- Format defined by hardware
- Per-page nature is repetitive
- Not enough bits to encode OS metadata
  - Disk sector address can be > 32 bits

# Dual-view Memory Model

## Logical

- Process memory is a list of *regions*
- “Holes” between regions are *illegal addresses*
- Per-region methods
  - `fault()`, `evict()`, `unmap()`

## Physical

- Process memory is a list of *pages*
- Faults delegated to per-region methods
- Many “invalid” pages can be made valid
  - But sometimes a region fault handler returns “error”
    - » Handle as with “hole” case above

# Page-fault story (for real)

**Examine fault address**

**Look up: address  $\Rightarrow$  region**

**`region->fault(addr, access_mode)`**

- *Quickly* fix up problem
- Or start fix, block process, run scheduler

# Summary

## The mysterious TLB

- No longer mysterious

## Process address space

- Logical: list of regions
- Hardware: list of pages

## Fault handler is *complicated*

- Demand-load from file, page in from paging area, ...