

# The Hippocampus as a Cognitive Map

Computational Models of Neural Systems  
Lecture 3.6

David S. Touretzky  
October, 2021

# Place Cells Are Found Throughout the Hippocampal System

- Place cells discovered in CA1 in rats by O'Keefe and Dostrovsky (1971)
- Continuous firing fields with gaussian falloff.
- Place fields cover the physical space, forming a “cognitive map” of the environment.

John O'Keefe  
2014 Nobel  
Laureate in  
Physiology or  
Medicine

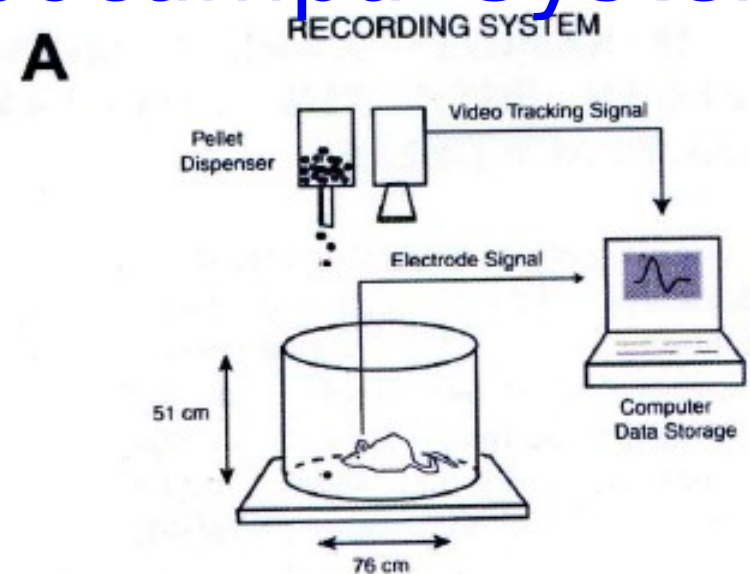

Sharp (2002)

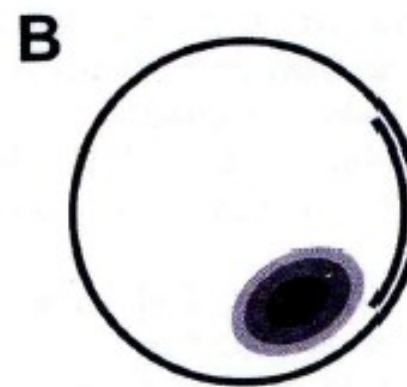

Individual Place Cell

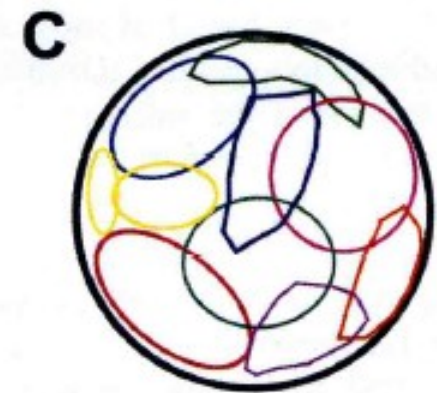

Population of Place Cells

# The Hippocampus as a Cognitive Map

- Psychologist E. C. Tolman coined the term “cognitive map” to describe an animal's mental representation of space.
  - Tolman, EC (1948) Cognitive maps in rats and men. *Psych. Review* 55(4):189-208.

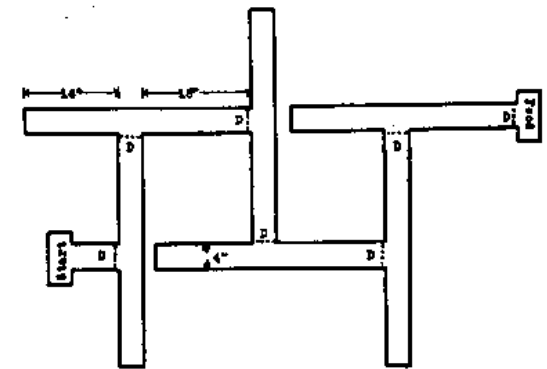

6-Unit Alley T-Maze

FIG. 4

(From H. C. Blodgett, The effect of the introduction of reward upon the maze performance of rats. *Univ. Calif. Publ. Psychol.*, 1929, 4, No. 8, p. 117.)

- O'Keefe and Nadel's book about place cells drew its title from Tolman's phrase.
  - O'Keefe, J and Nadel, L. (1978) *The Hippocampus as a Cognitive Map*. Oxford University Press.
  - Now online at <http://www.cognitivemap.net>

# Properties of Place Fields

- Appear instantly in a new environment, but take 10-20 minutes to fully develop.
- Can be controlled by distal visual cues. (Rotate the cues and the fields will rotate.)
- Persist in the dark – so not *dependent* on visual input.
  - Driven by path integration?
- Only about 1/3 of place cells have fields in a typical small environment.
- Cells have unrelated fields in different environments.

# Place Fields in a Cylindrical and Square Arena

- Roughly gaussian
- Modest peak firing rates (5-10 Hz)
- Largely unrelated fields in the two environments

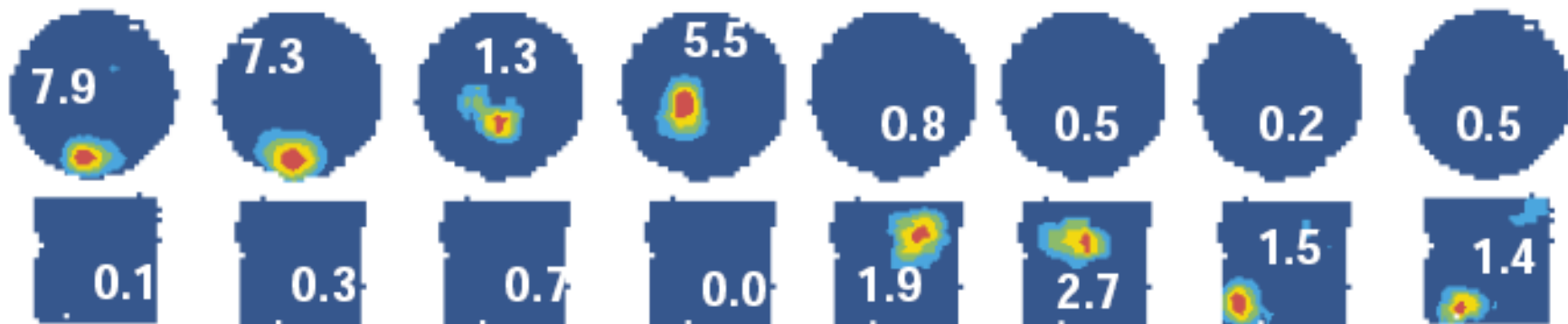

Lever et al., 2002

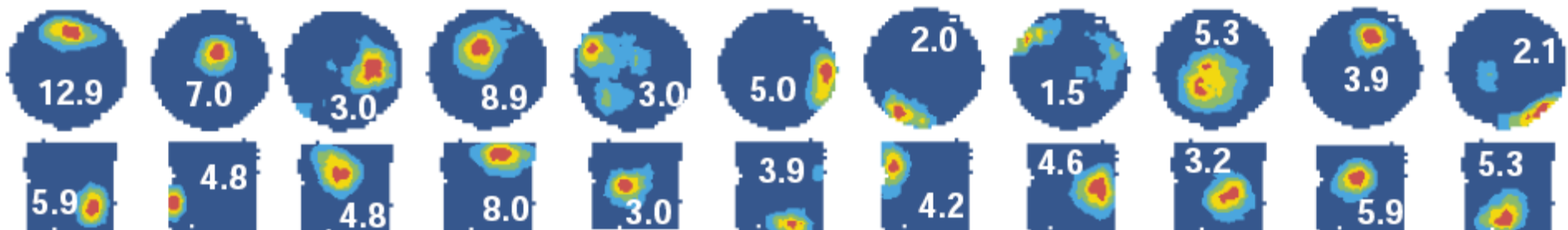

# Place Fields On A Maze

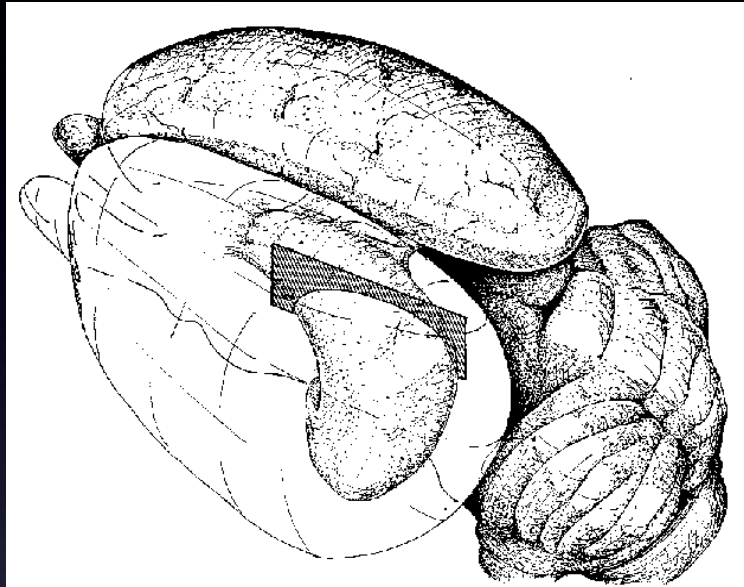

Slide courtesy of Anoopum Gupta

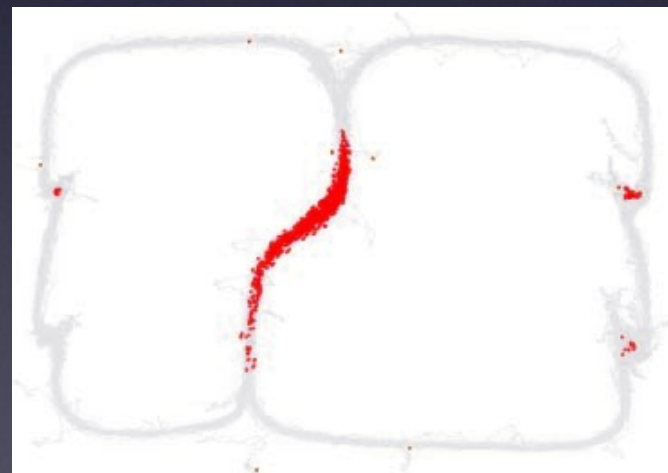
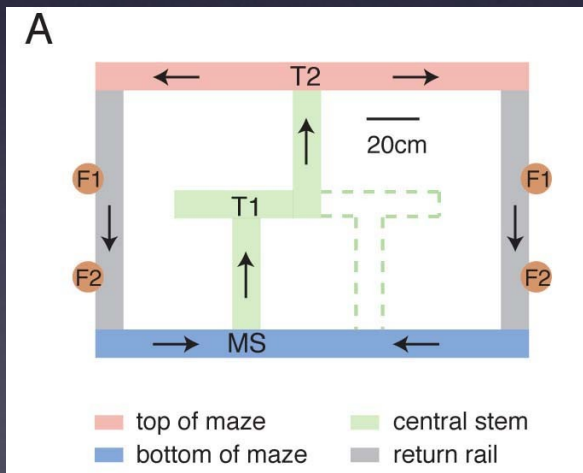

Cell 1



Cell 2

# Neural activity during behavior

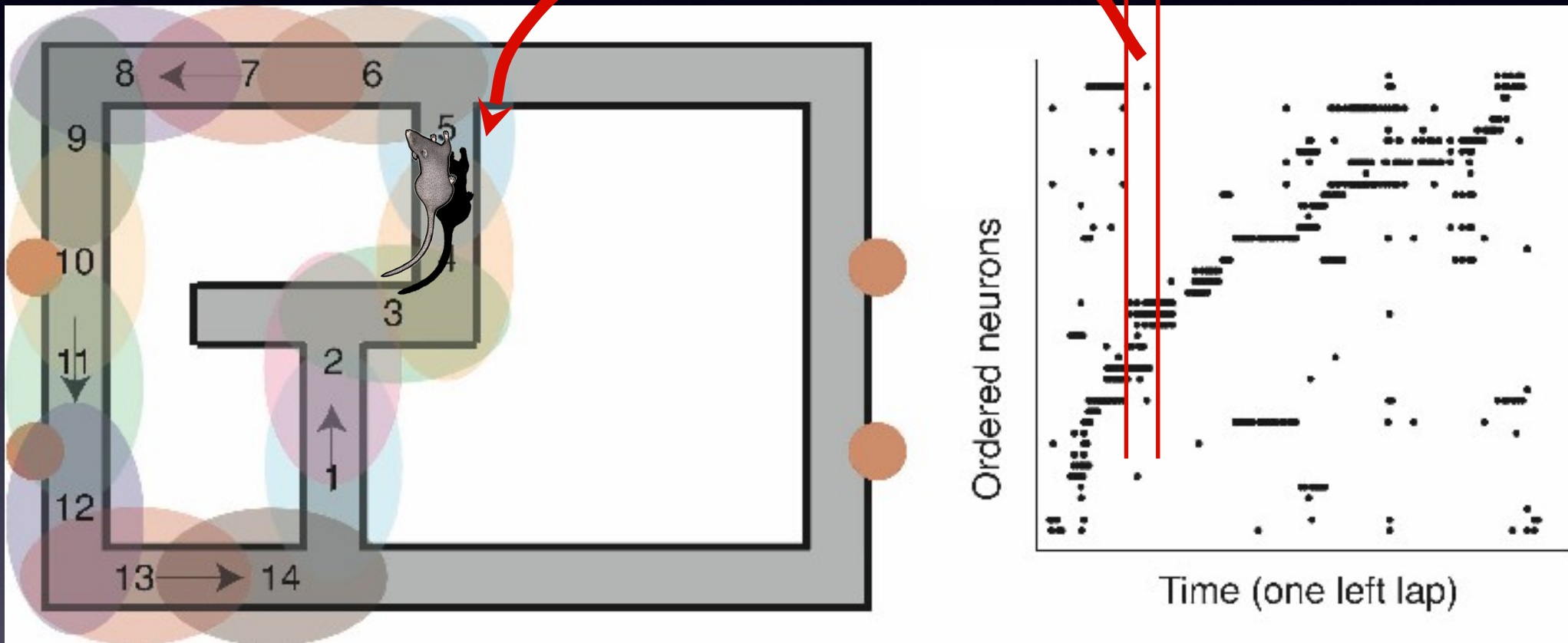



# Theta Phase Precession

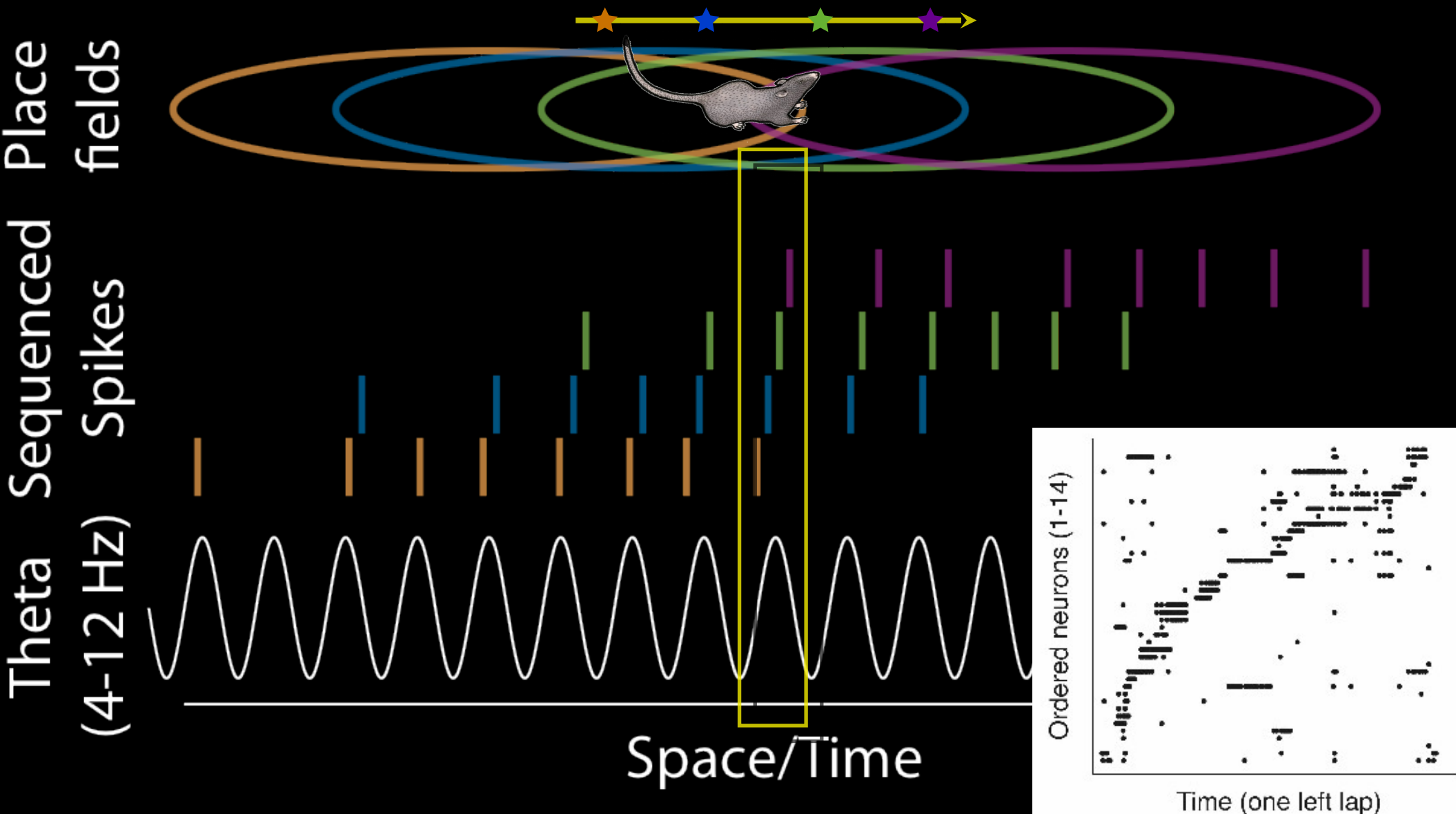

Slide courtesy of Anoopum Gupta



# Decoded Paths

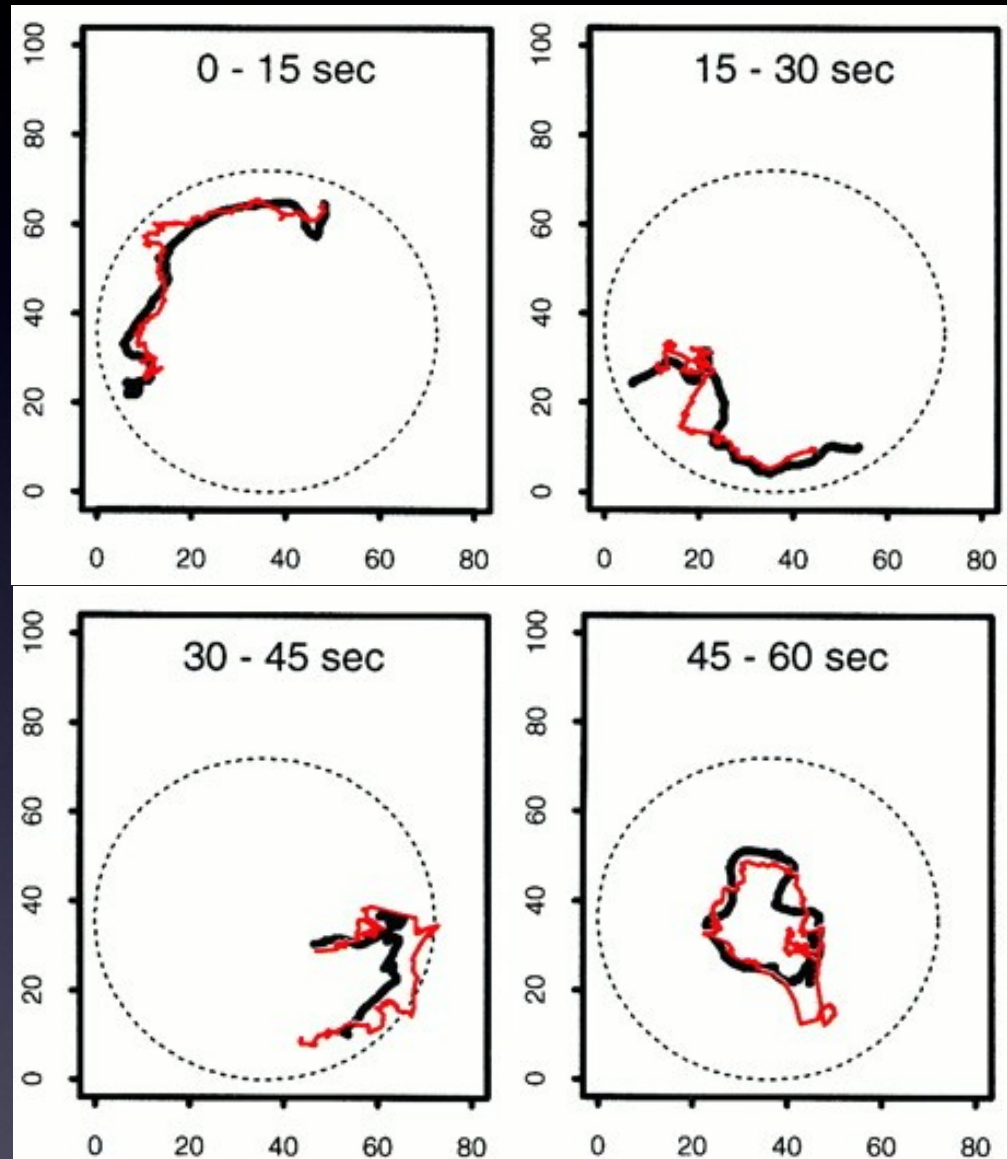

Brown et al., 1998

# Eleanor Maguire: Spatial Memory in Humans

- London cab drivers undergo 2-3 years of training to learn “The Knowledge” of London's complex streets.
- Cab drivers have larger posterior hippocampi than controls. Experienced drivers show greater enlargement than new drivers.
- When remembering complex routes, drivers show elevated activity in right posterior hippocampus; no increase when answering questions about historical landmarks.

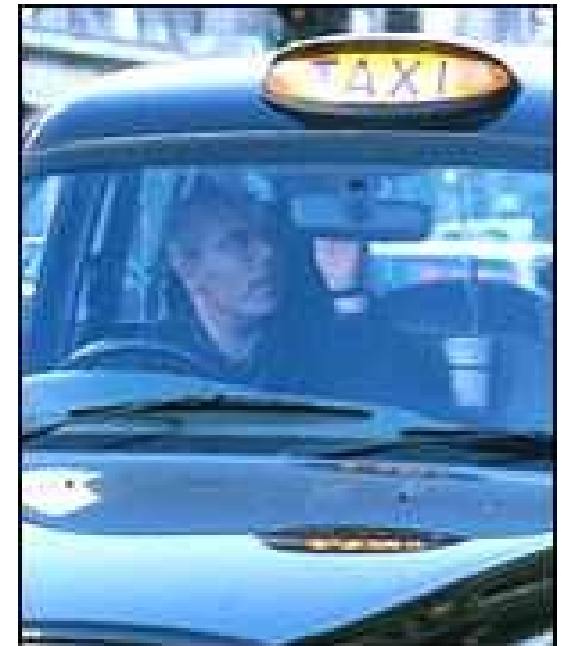

# Head Direction Cells (Ranck, 1989)

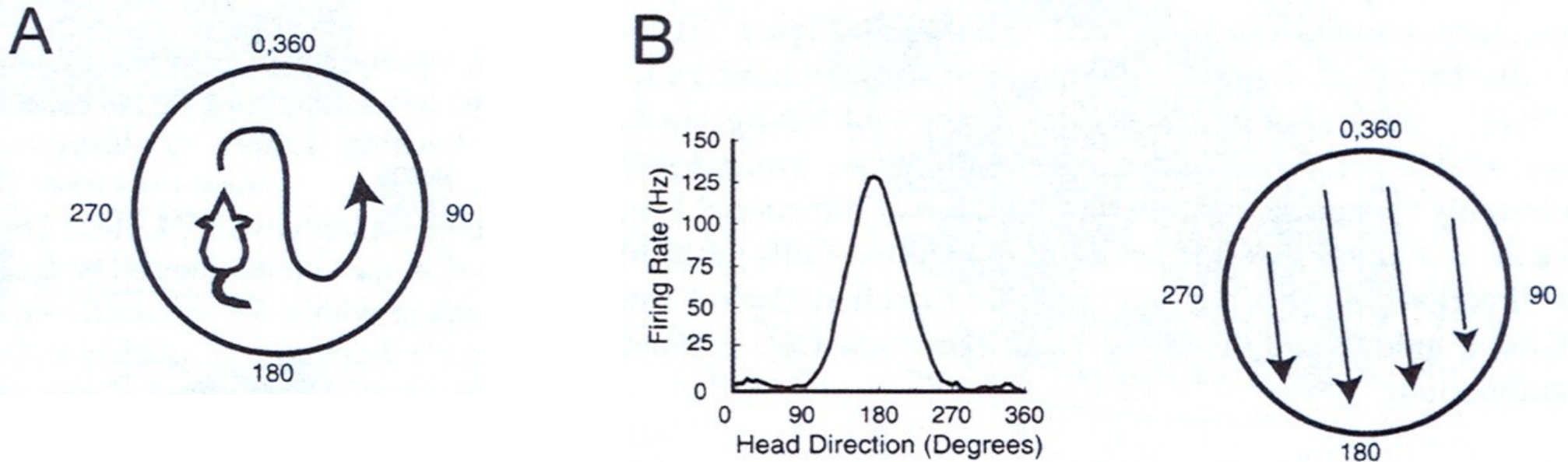

Individual Head Direction Cell

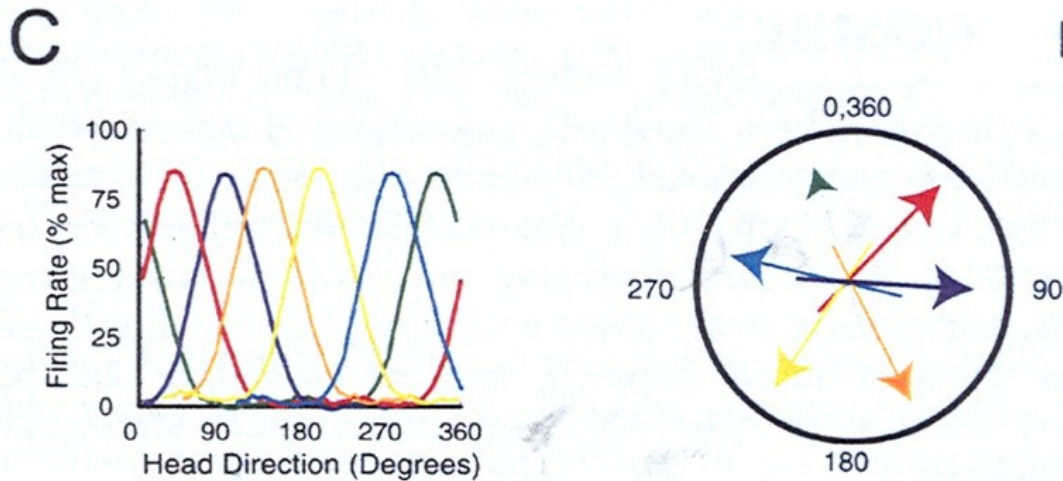

Population of Head Direction Cells

Figures from Sharp (2002)

# Place and Head Direction Systems

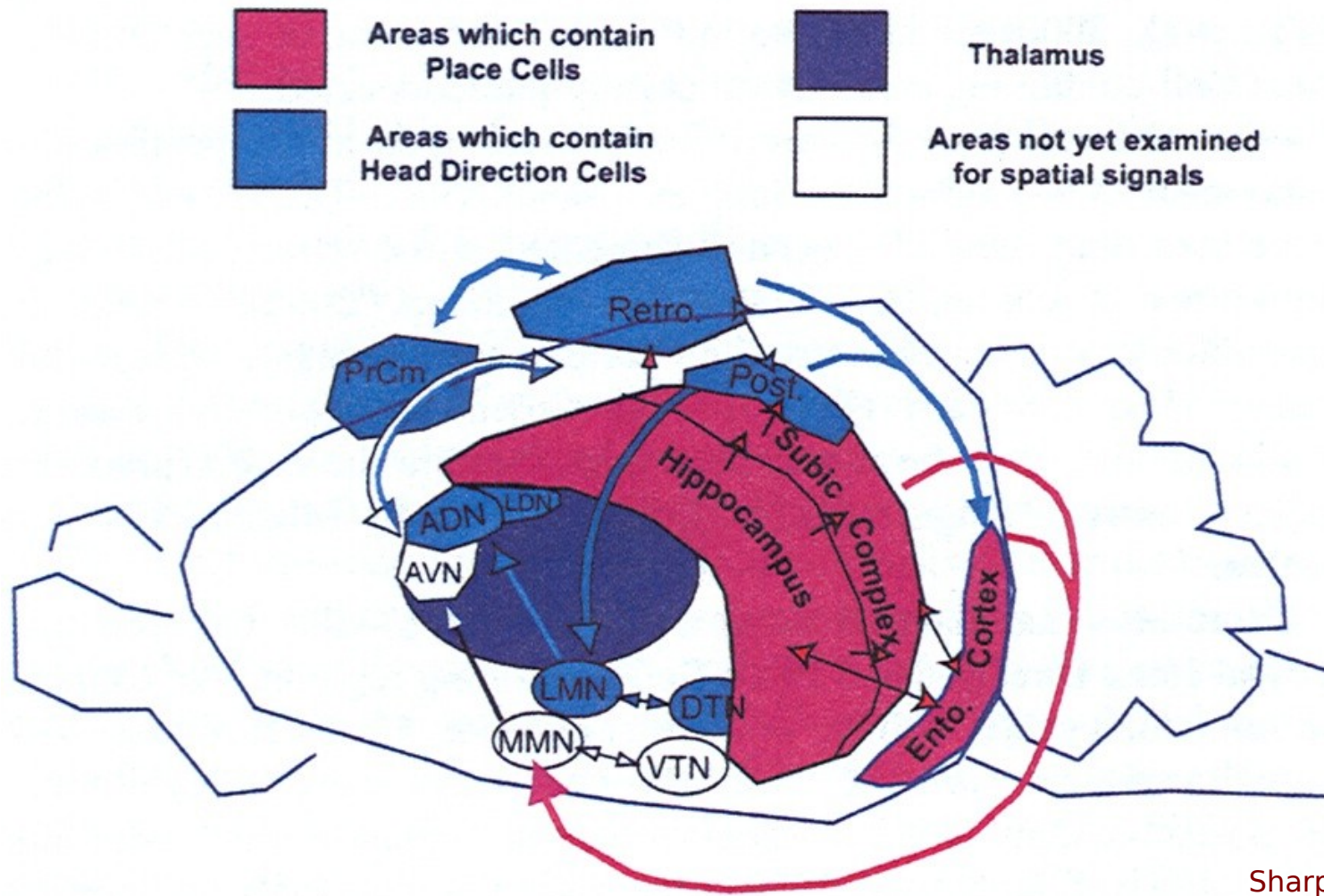



# Rodent Navigation Circuit

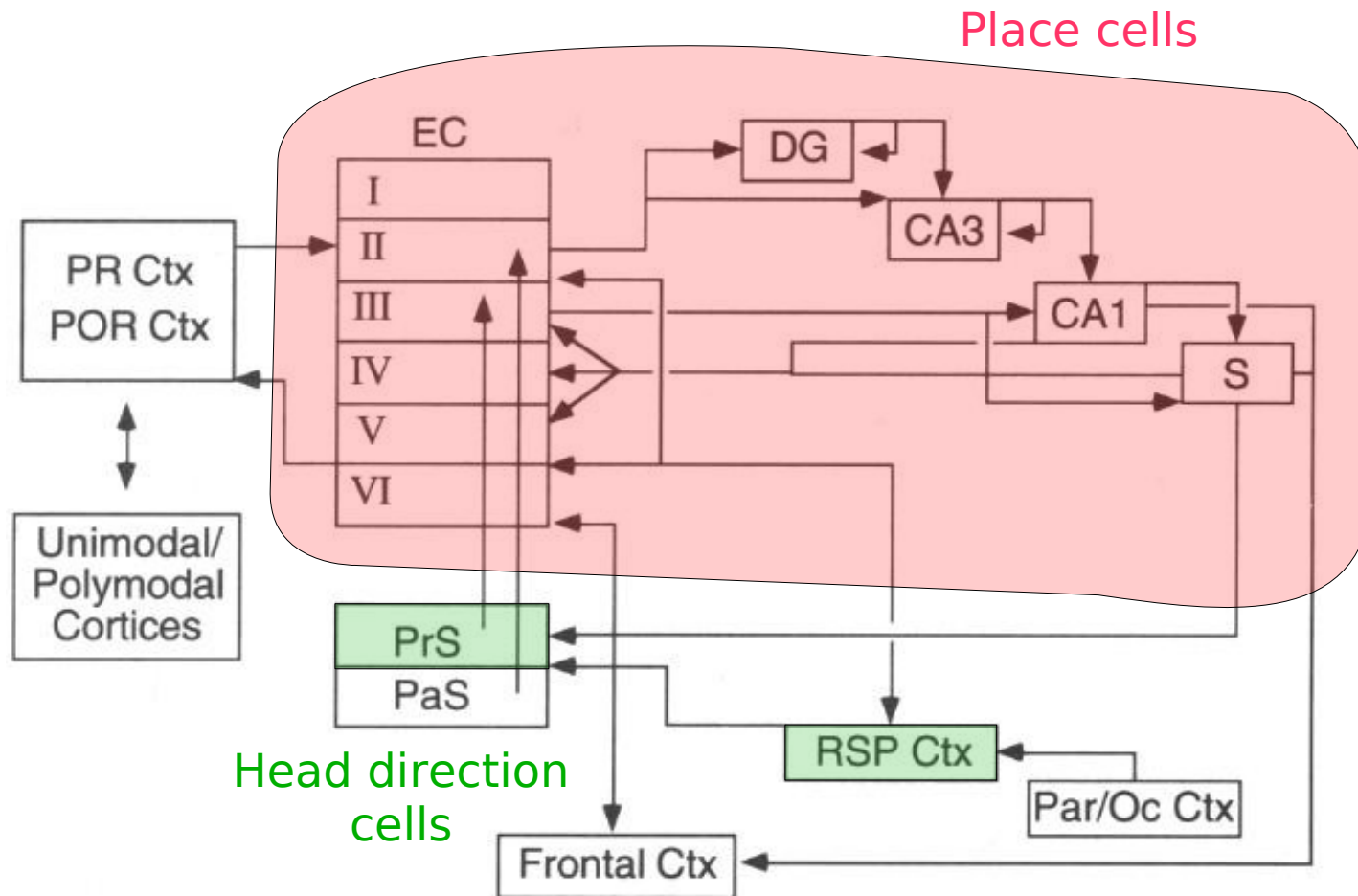

From (Johnston & Amaral, 1998)

PR: perirhinal cortex; POR: postrhinal cortex; EC: entorhinal cortex; PrS: presubiculum; PaS: parasubiculum; DG: dentate gyrus; CA: Cornu amonis; S: subiculum; RSP: retrosplenial cortex; Par/Oc: parietal/occipital cortex

# Path Integration in Rodents

Mittelstaedt & Mittelstaedt (1980): gerbil pup retrieval

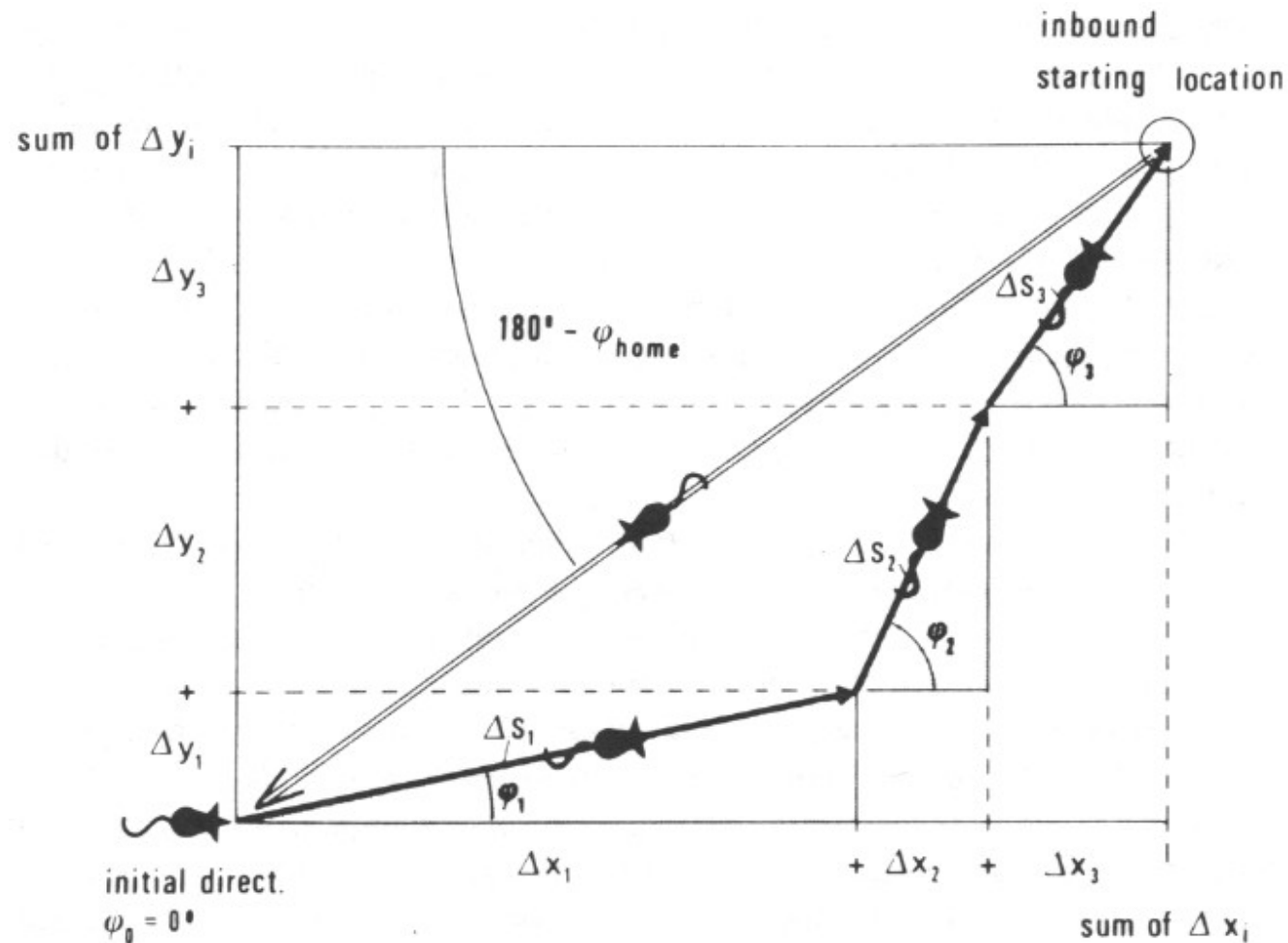

# Redish & Touretzky Model of Rodent Navigation

Place cells *learn* and *maintain* the correspondence between local view representations and path integrator coordinates.

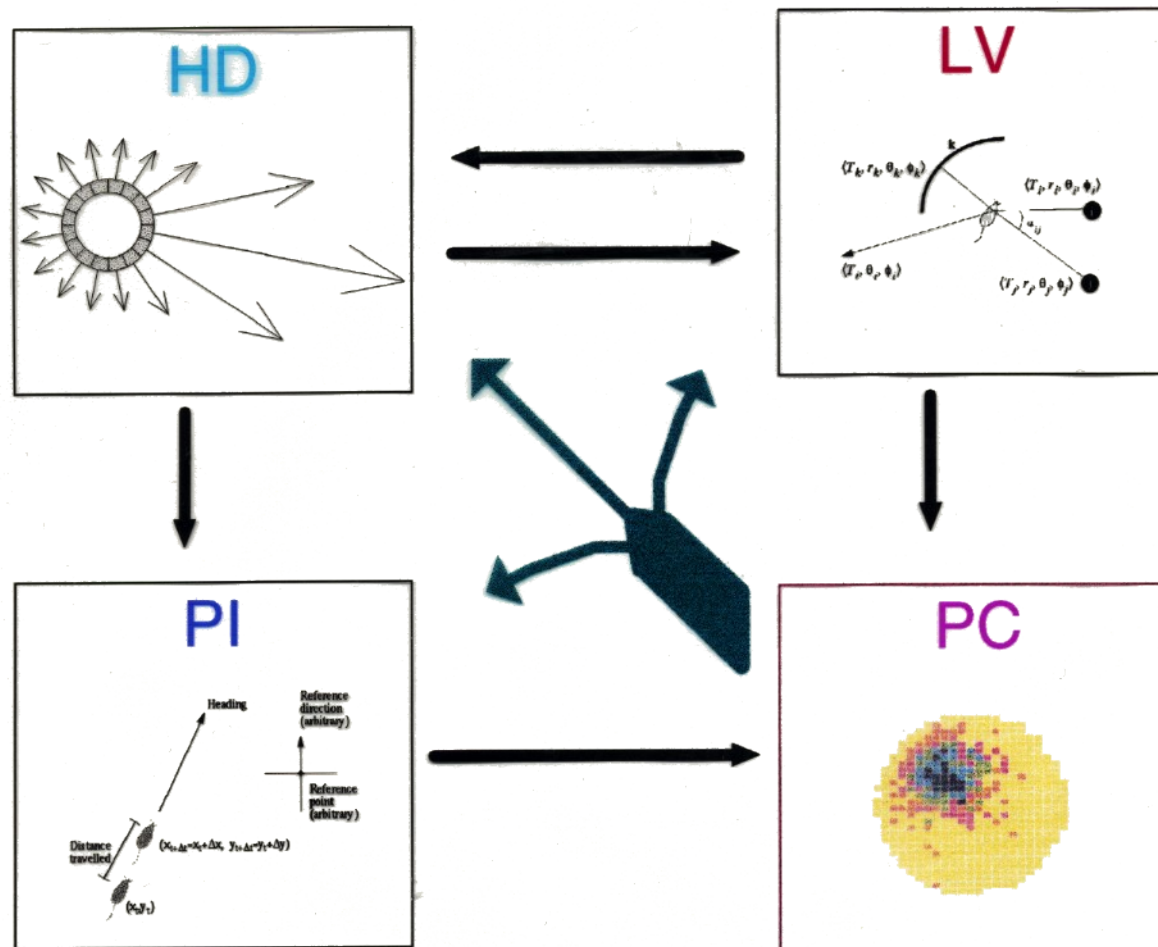

Redish (1997)



# Hippocampal State: A Moving Bump of Activity

Activity packet reconstructed  
from firing patterns of around  
100 cells recorded  
simultaneously by Wilson &  
McNaughton (1993)

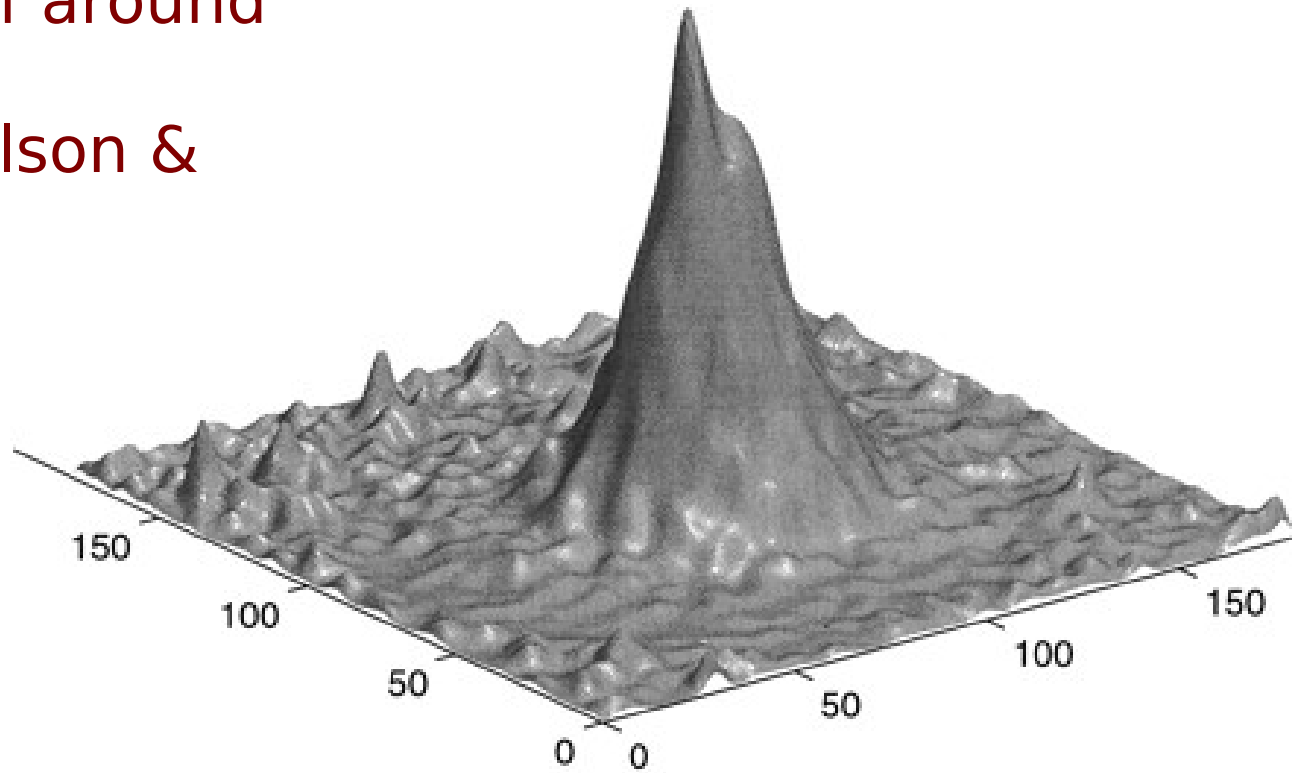

Samsonovich & McNaughton (1997)

# 2D Attractor Bump Simulation

- In 1972, Amari, and Wilson & Cowan demonstrated continuous attractor bumps in a recurrent network.
- 25 years later: Samsonovich & McNaughton (1997): 2D attractor bump model of place cells.
- Bumps are easy to simulate and visualize in MATLAB.

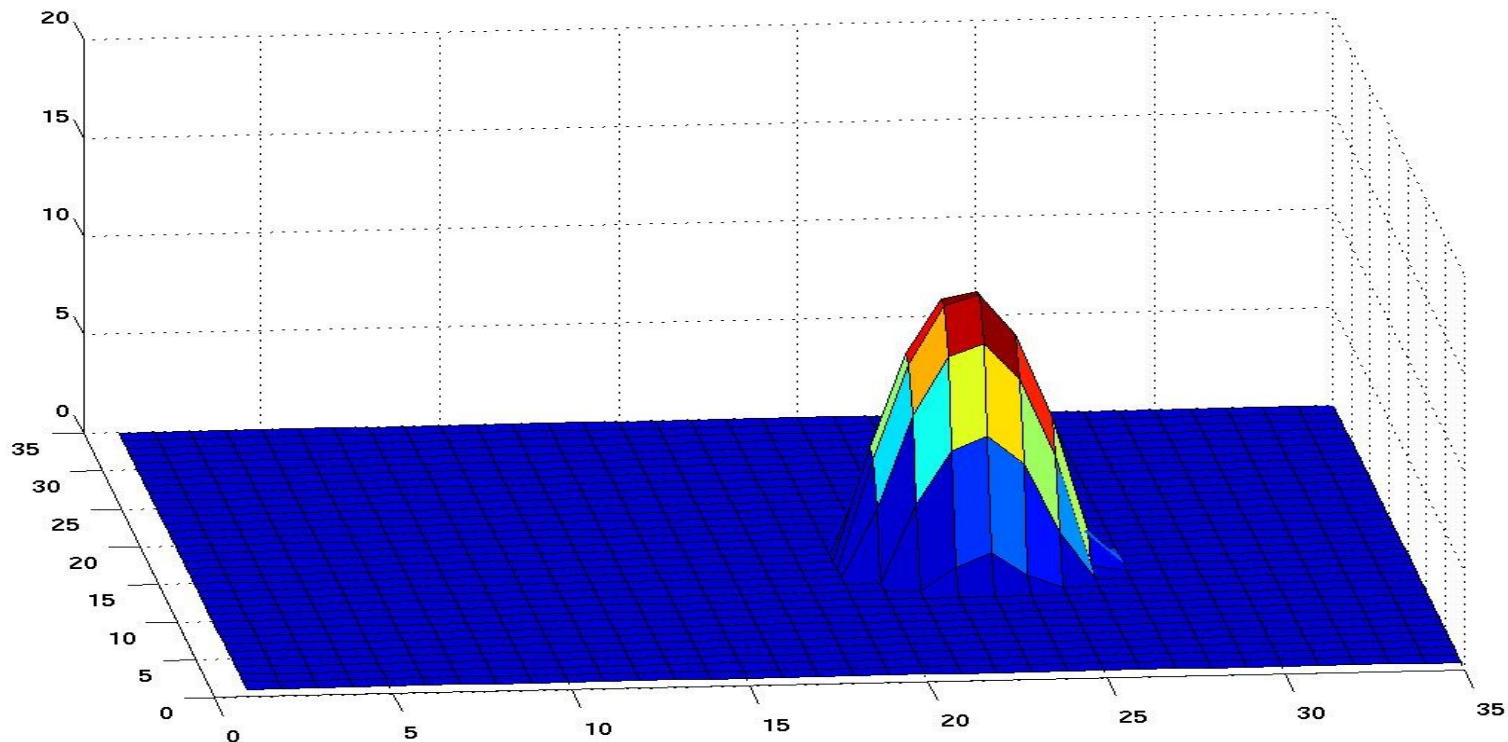

# How to make a bump (1D version)

Local excitation plus global inhibition:

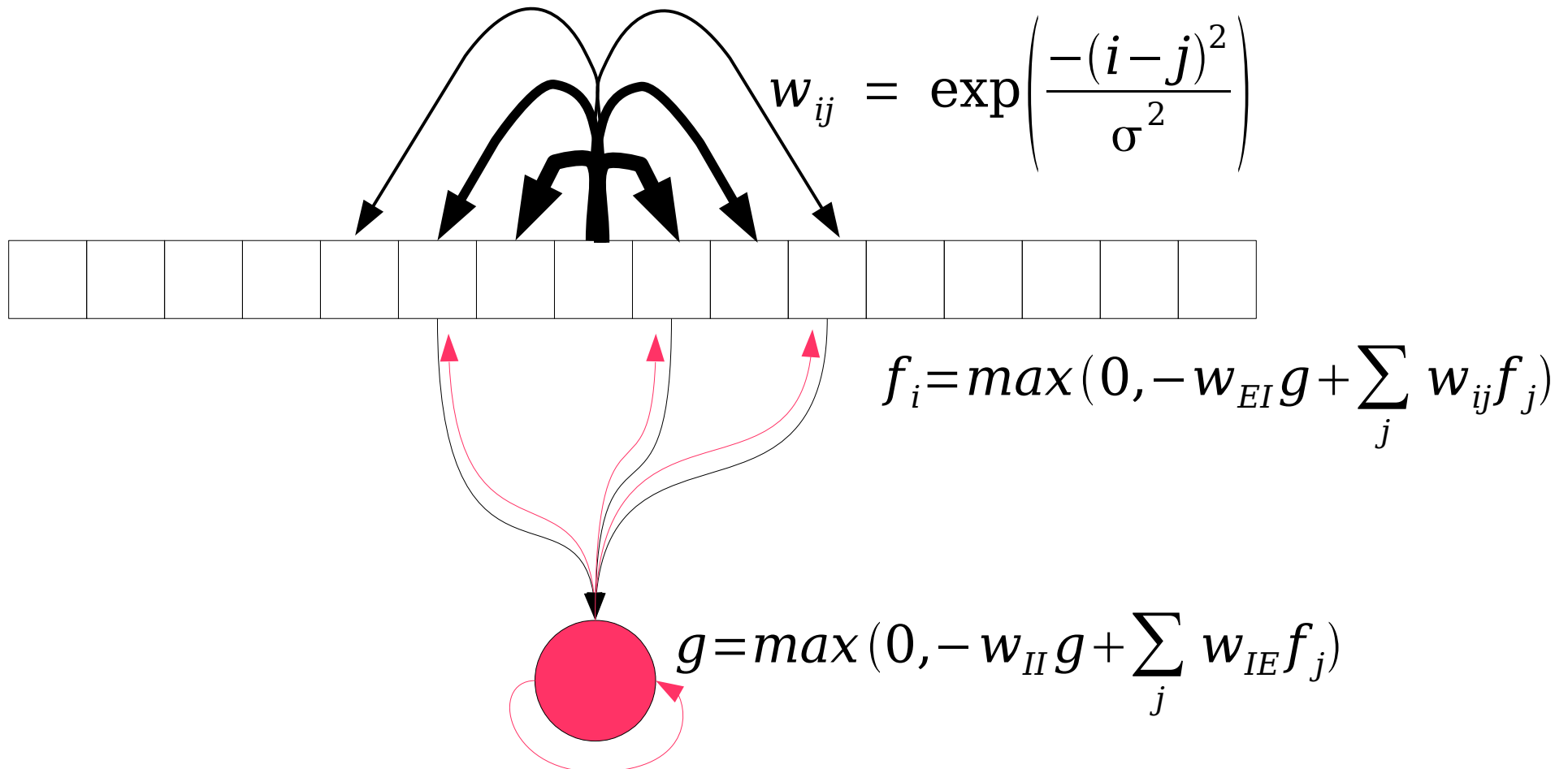

# How to make a bump (1D version)

Same weights for every unit (shifted):

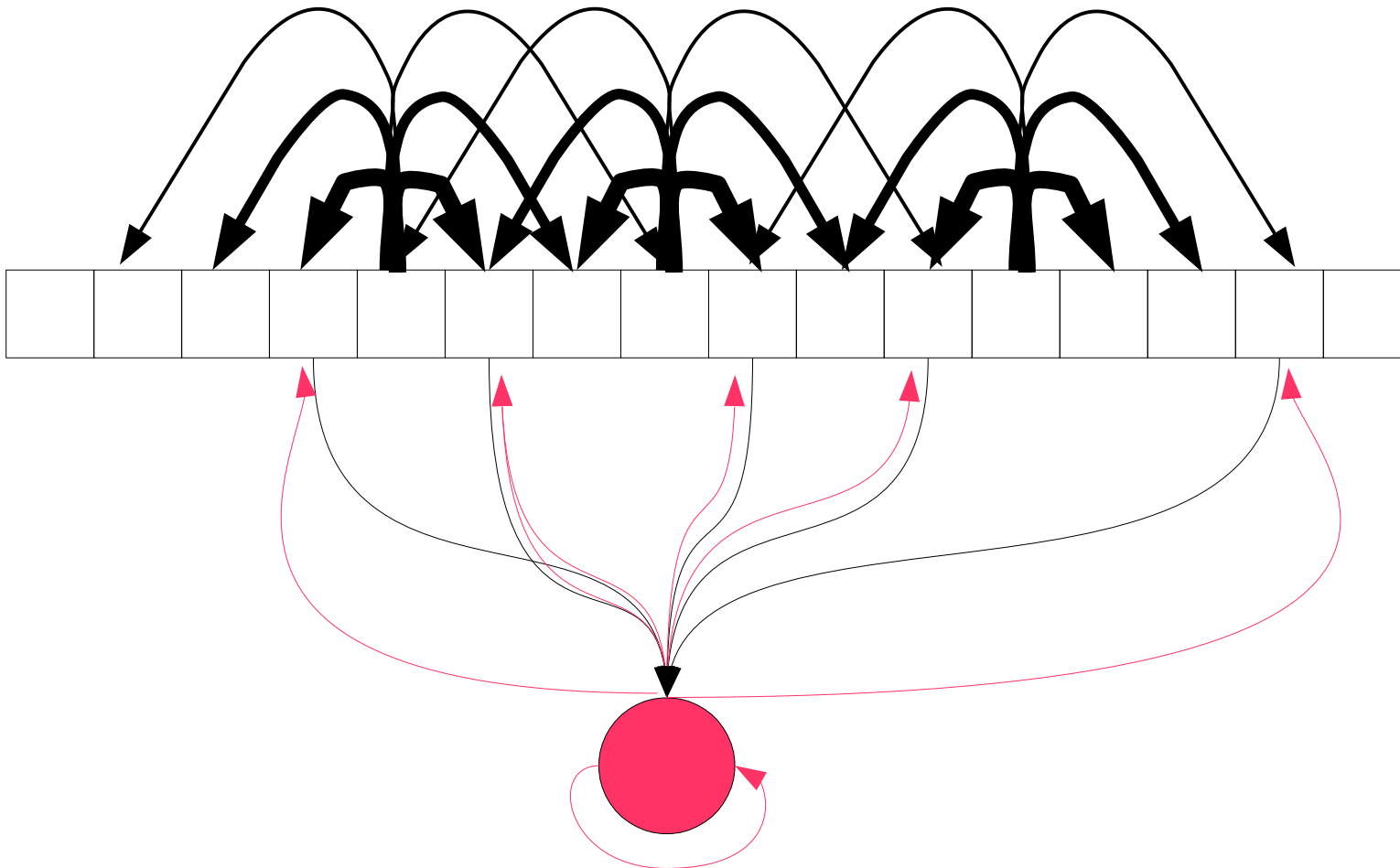

# Gothard et al. (1996): bump jumps

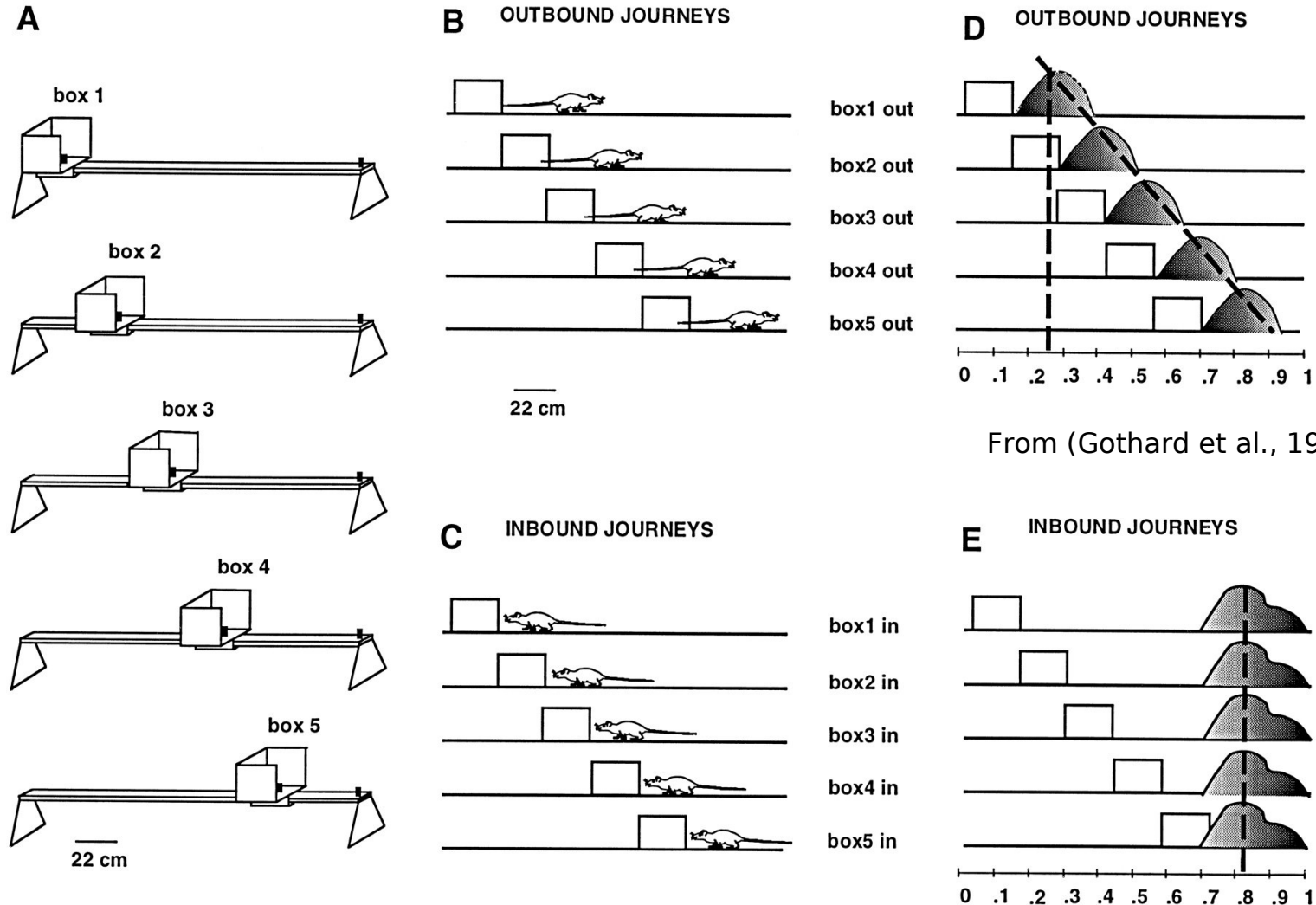

# Watch the bump jump!

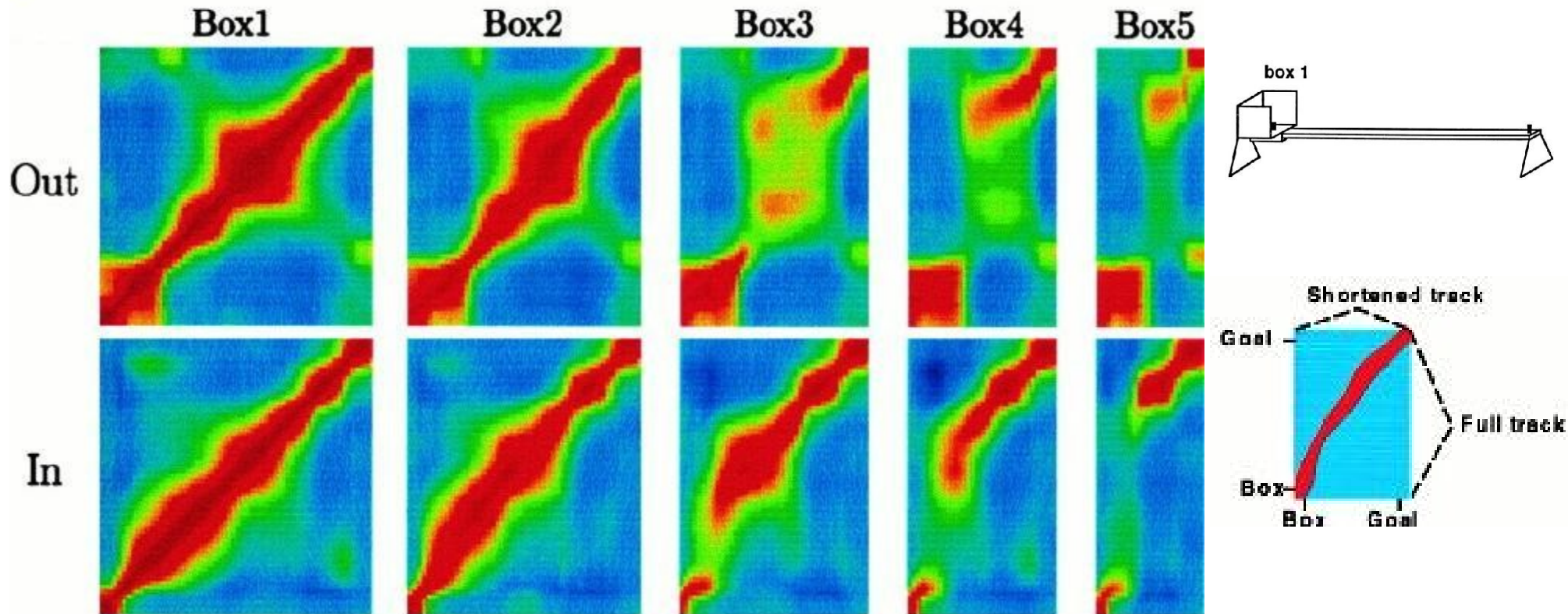

From (Gothard et al., 1996)

Cross-correlation plots of the ensemble activity patterns show a “jump” on the map as a discontinuity.

# Samsonovich & McNaughton Model

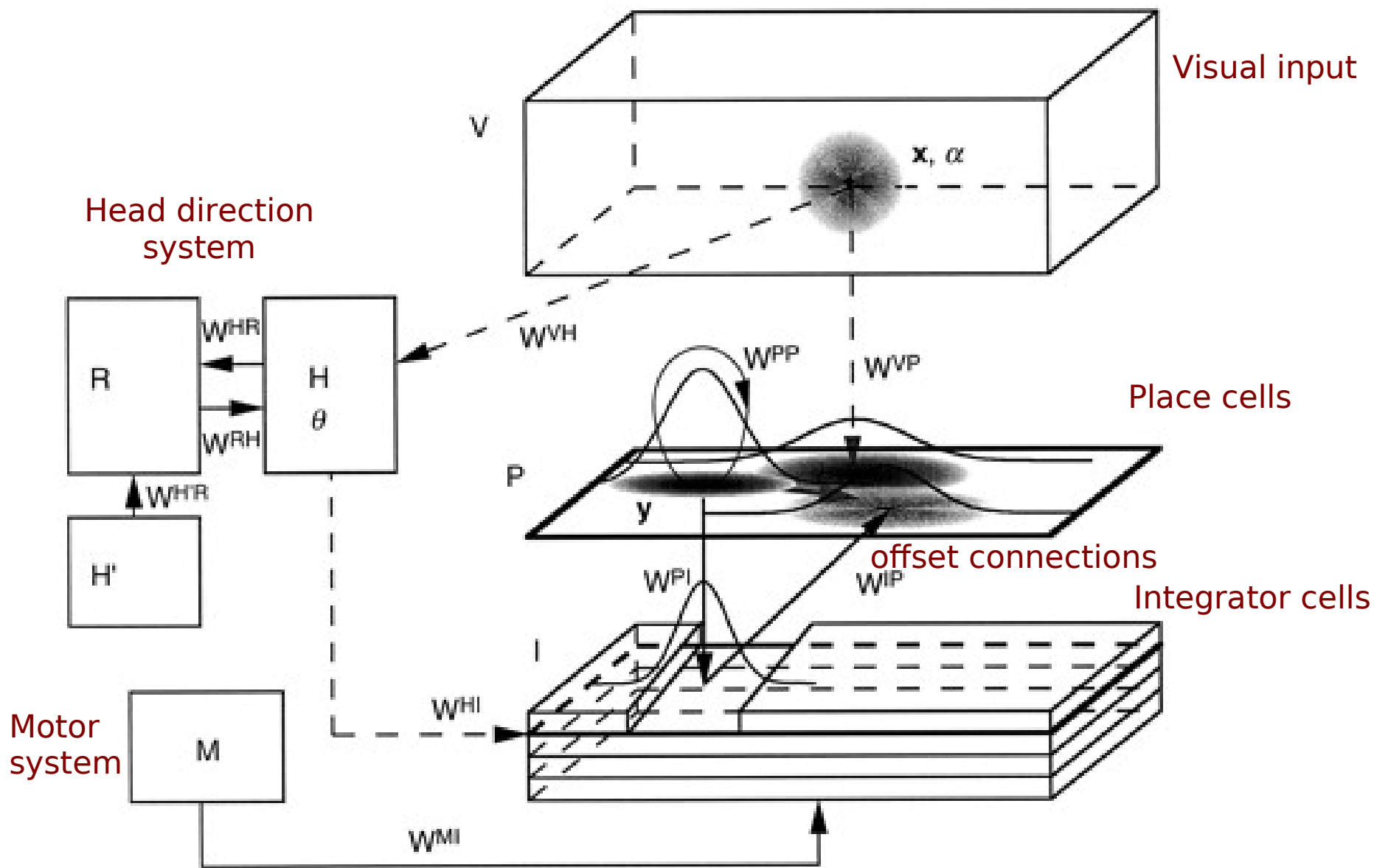



# Where is the Path Integrator?

- Early theories (McNaughton) placed it in hippocampus.
- Redish & Touretzky: it can't go there, because multiple maps make it too hard to update position.
- Fyhn et al. (Science, 2004) found the PI in medial entorhinal cortex: “grid” cells.



May-Britt and Edvard Moser,  
2014 Nobel Laureates in  
Physiology or Medicine

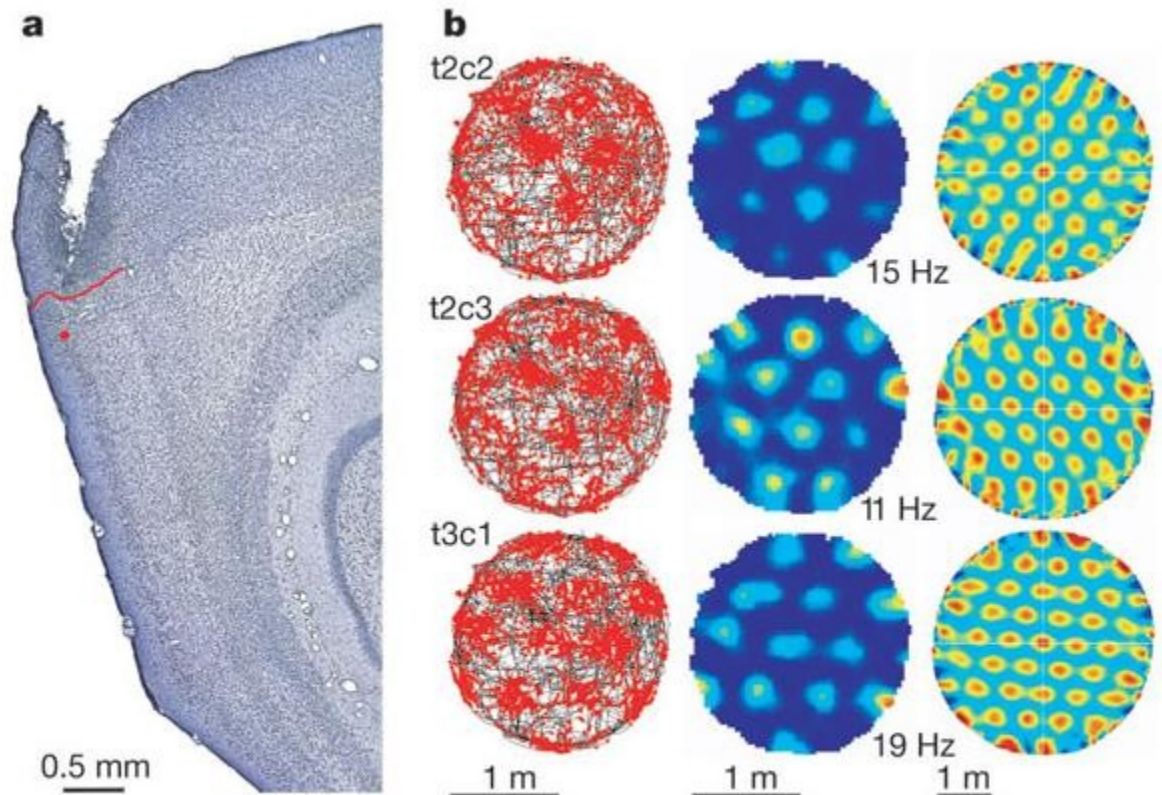

# Multiple Maps in Hippocampus

Samsonovich & McNaughton's "charts" proposal:

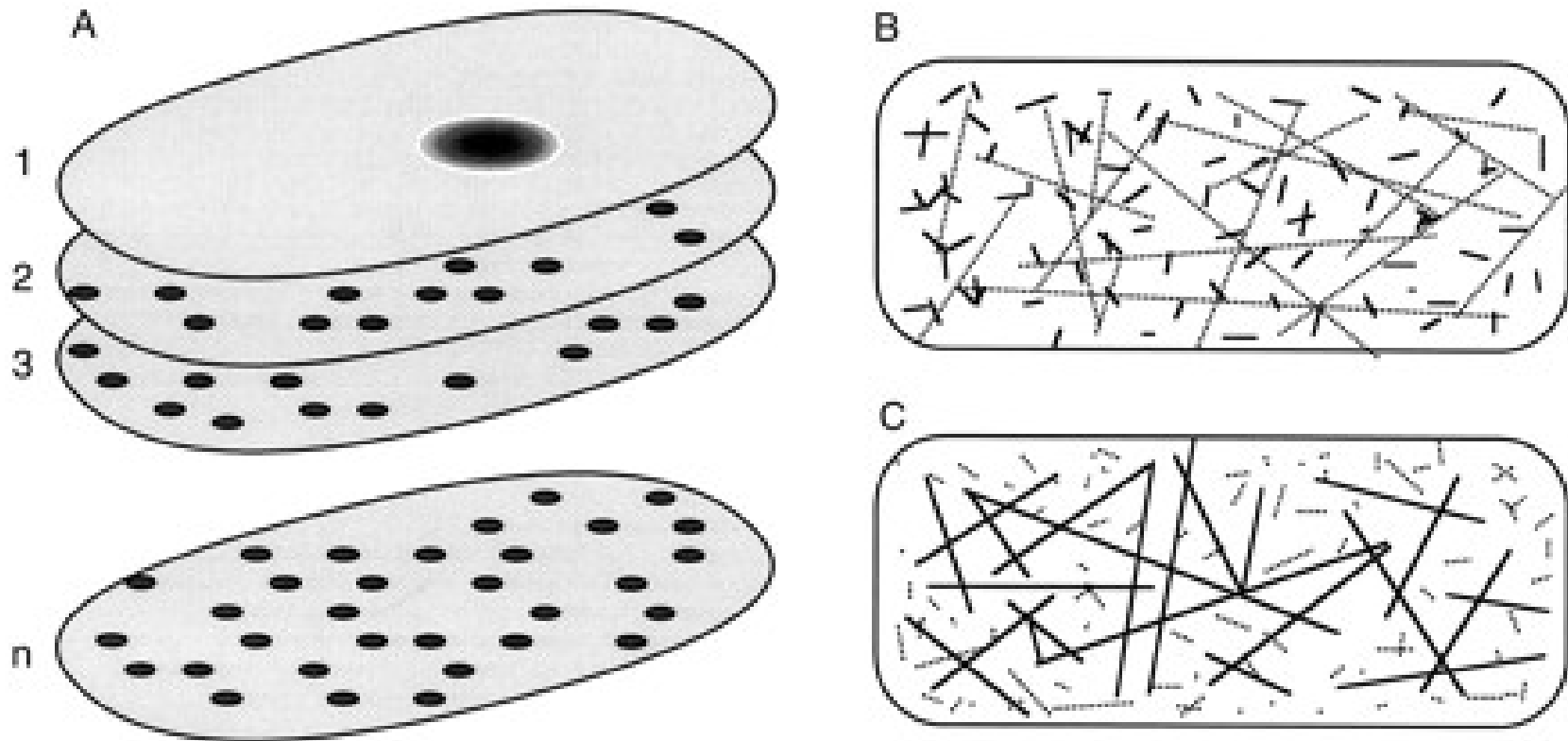

# How to make multiple maps (1D case)

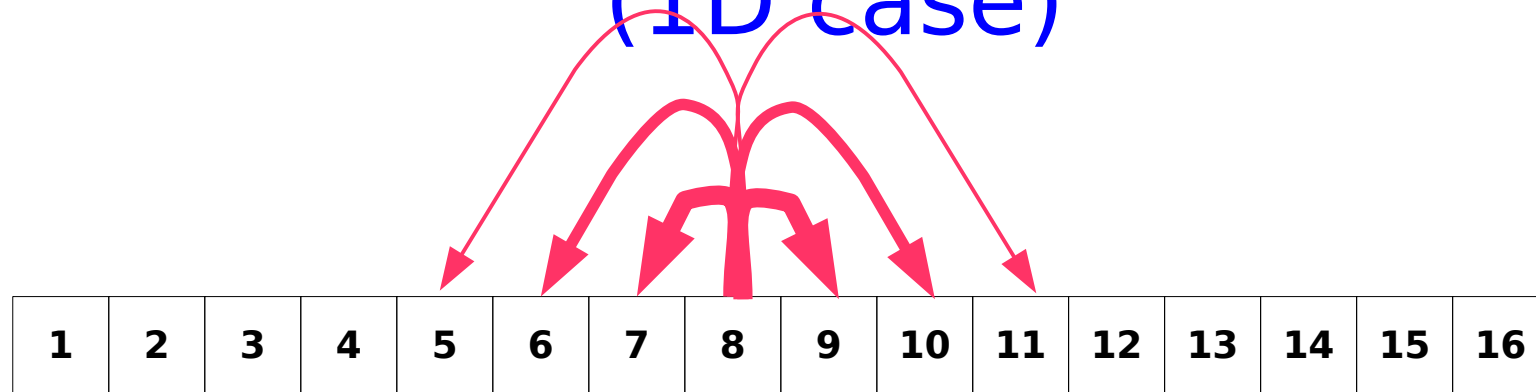

Shuffle  
the  
units

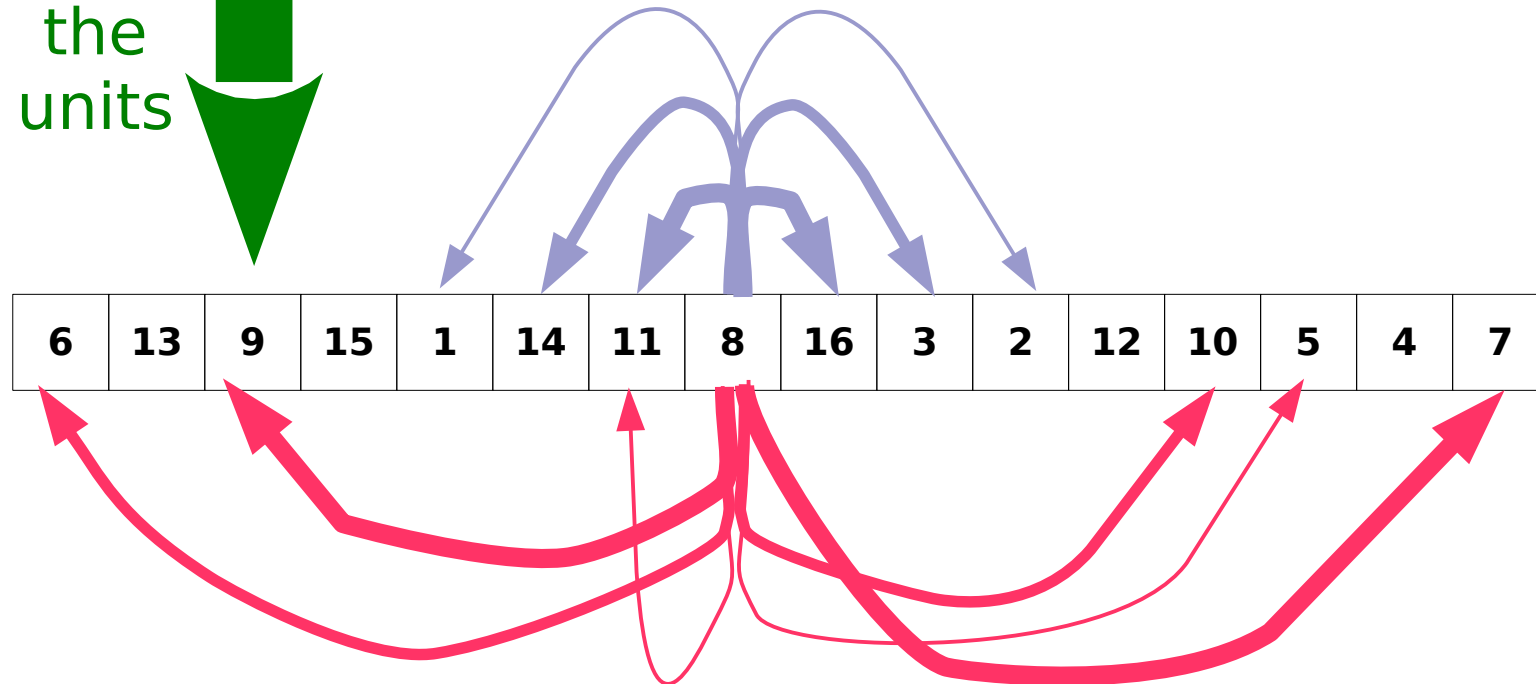

# Multiple Maps Can Co-Exist In An Attractor Network

Because activity patterns are sparse, the weight matrix is also sparse. Interference isn't too bad.

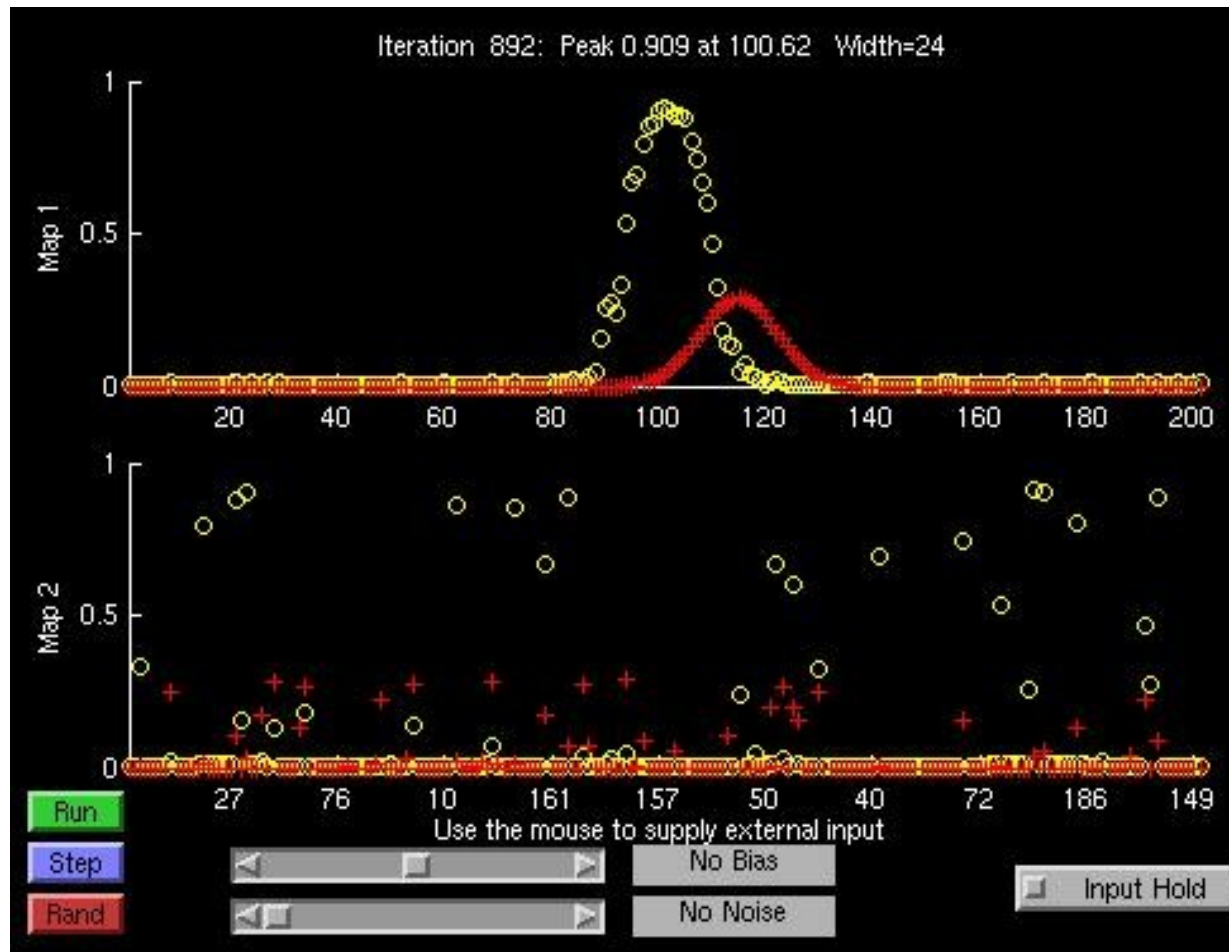

# Skaggs & McNaughton (1998): Partial Remapping in Identical Environments

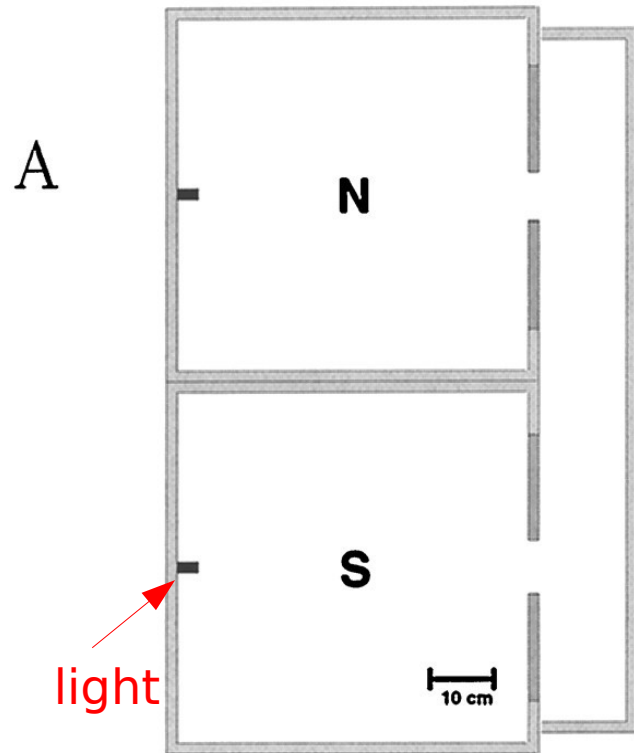

B

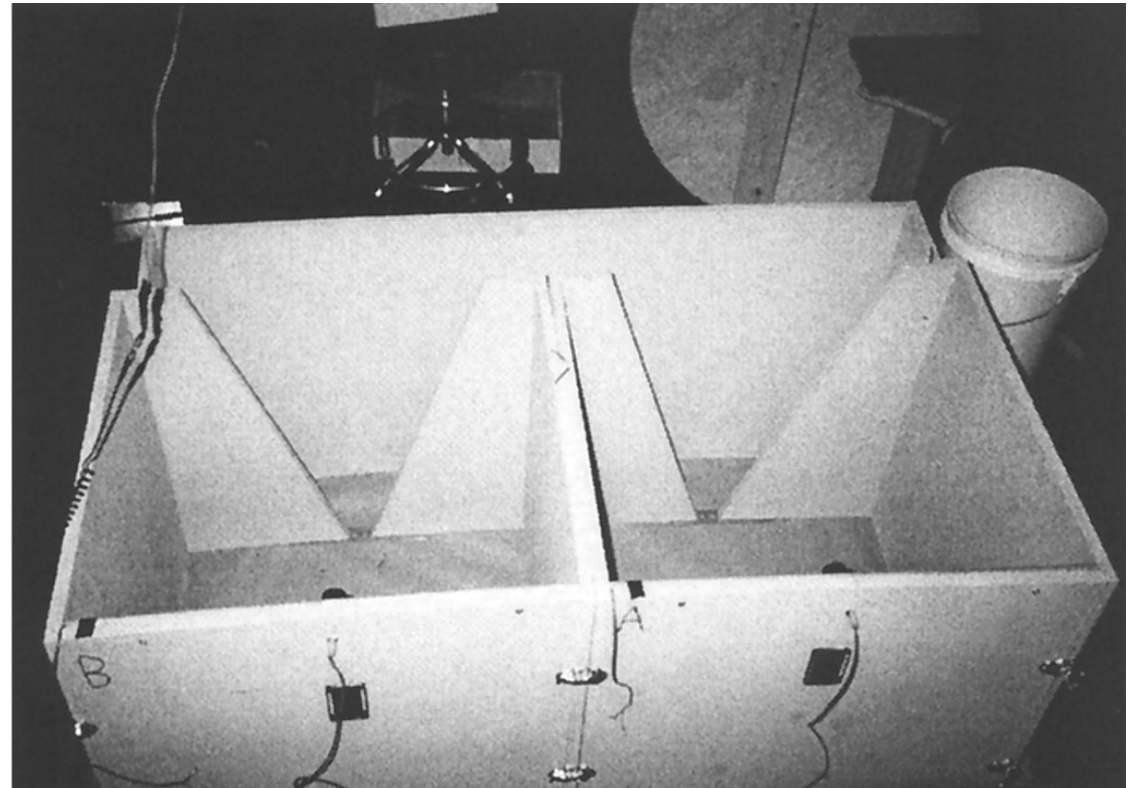

(Skaggs & McNaughton, 1998)



# Identical Environments, Similar Fields in Both Boxes

Same cell;  
two sessions

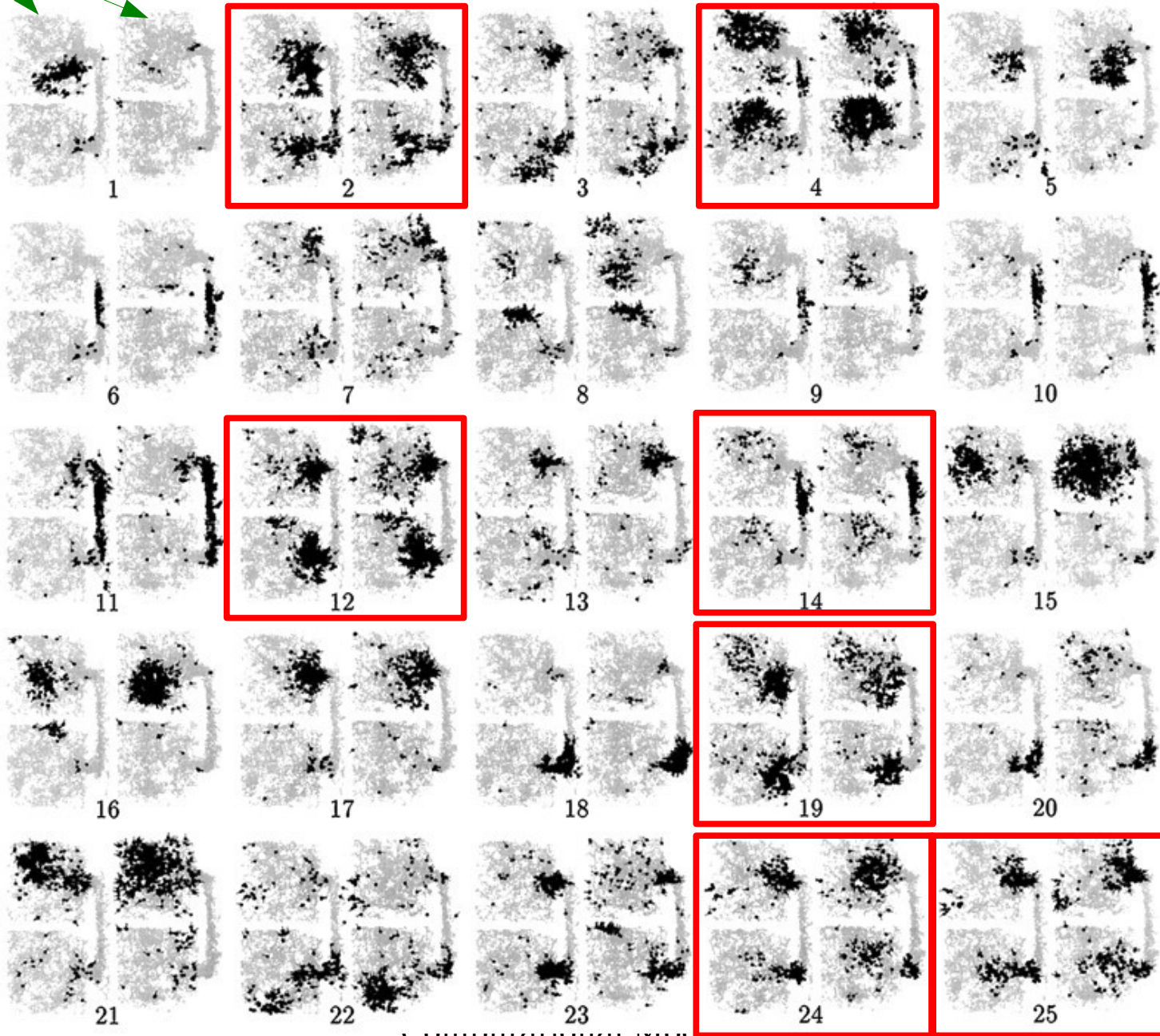

Skaggs &  
McNaughton  
(1998), Fig. 2.

# Task-Dependent Hippocampal Remapping

Oler and Markus (2000) recorded from DG, CA3, and CA1 while animals ran either on a Figure-8 or Plus maze.

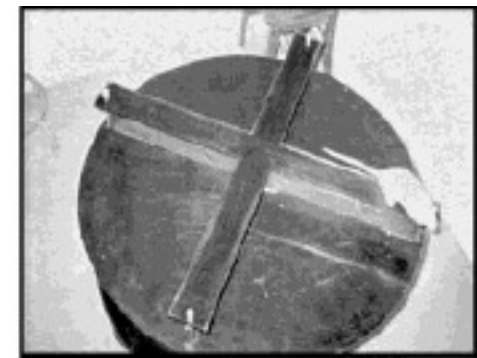
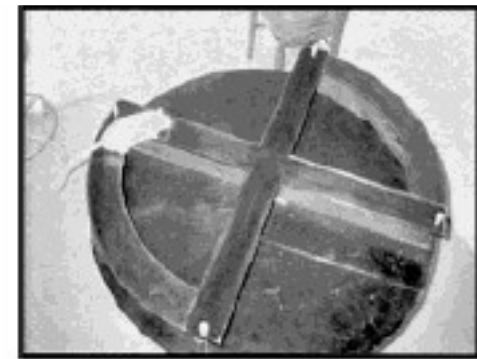
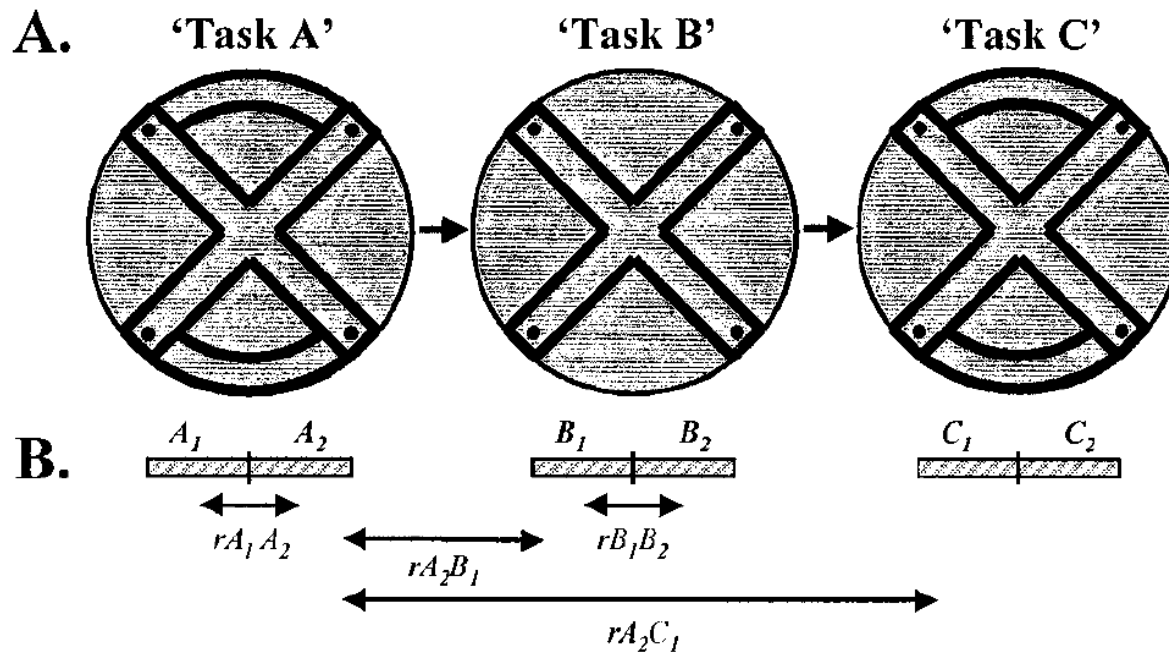



# Task-Dependent Remapping

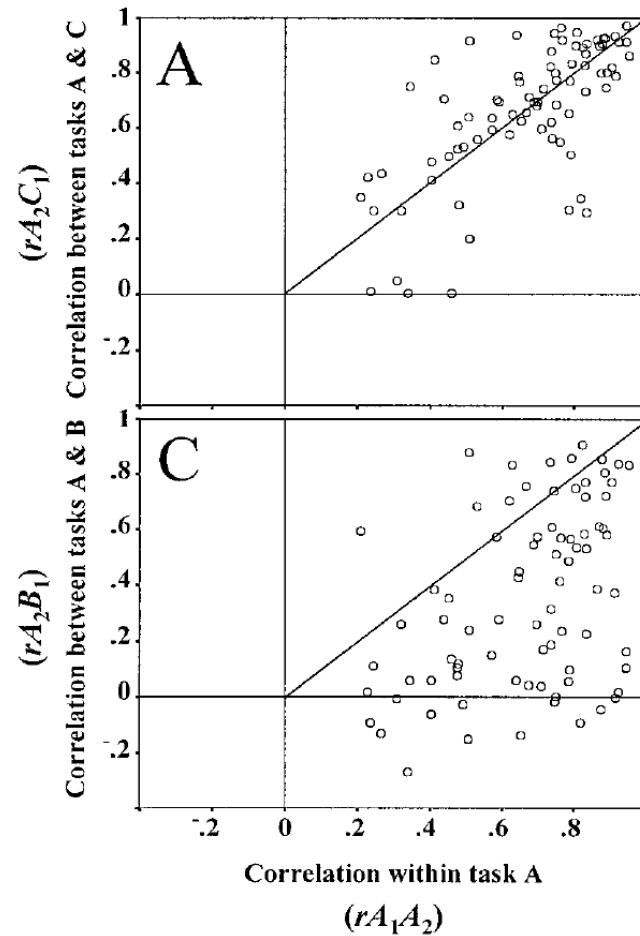
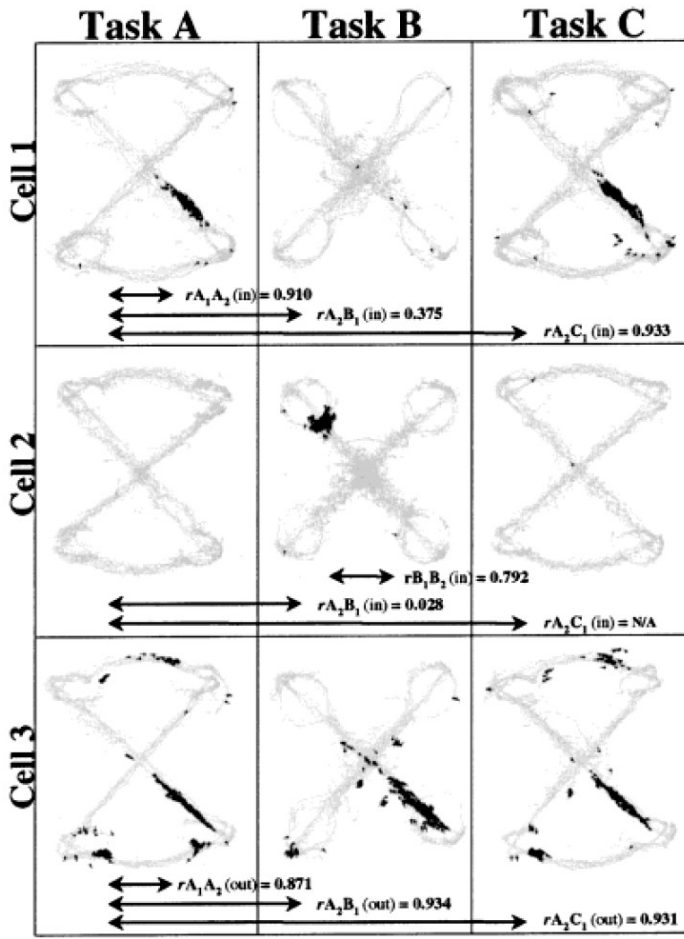

Some but not all fields remapped depending on which task was being performed

# Experience-Dependent Remapping

In some circumstances, rats don't remap right away:

- **Onset** may be delayed.
  - So cannot be direct result of a sensory change.
  - Must reflect some internal change in the rat's representation of its environment: learning.
- **Rate** may be gradual.
  - The time course of remapping tells us something about the experience-dependent learning process.
- **Extent** may be partial or complete.
- What **learning algorithm** is responsible for these experience-dependent changes?

# Bostock et al. (1991): Delayed Abrupt Complete Remapping

- Train in cylinder with white card, then alternate exposure to white and black cards.
- Most rats did not remap upon first exposure to black card.
- But once a rat remapped, it continued to do so.

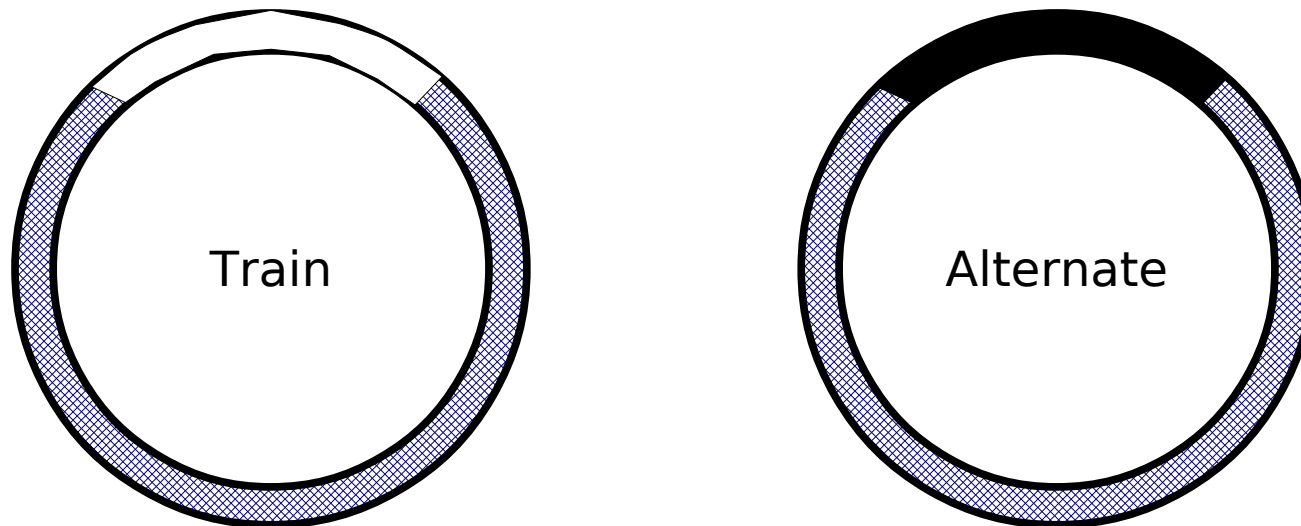

# Tanila et al. (1997): Gradual Remapping

- Discordant responses: some cells followed local cues, some followed distal, some remapped. The extent of remapping appeared to increase over several days. (Based on data summed over rats.)
- Is the rat becoming more *certain* that the two environments are reliably different?

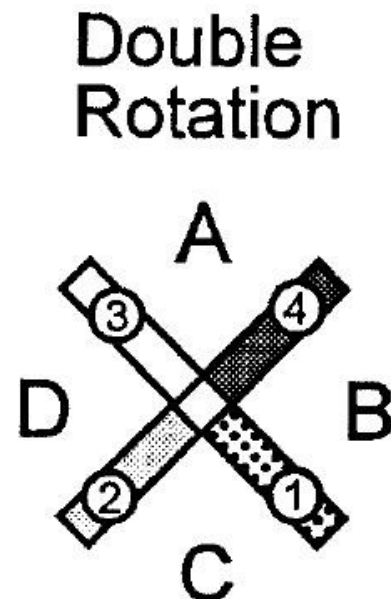
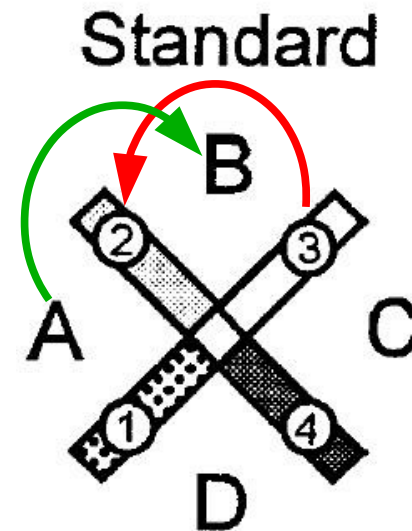
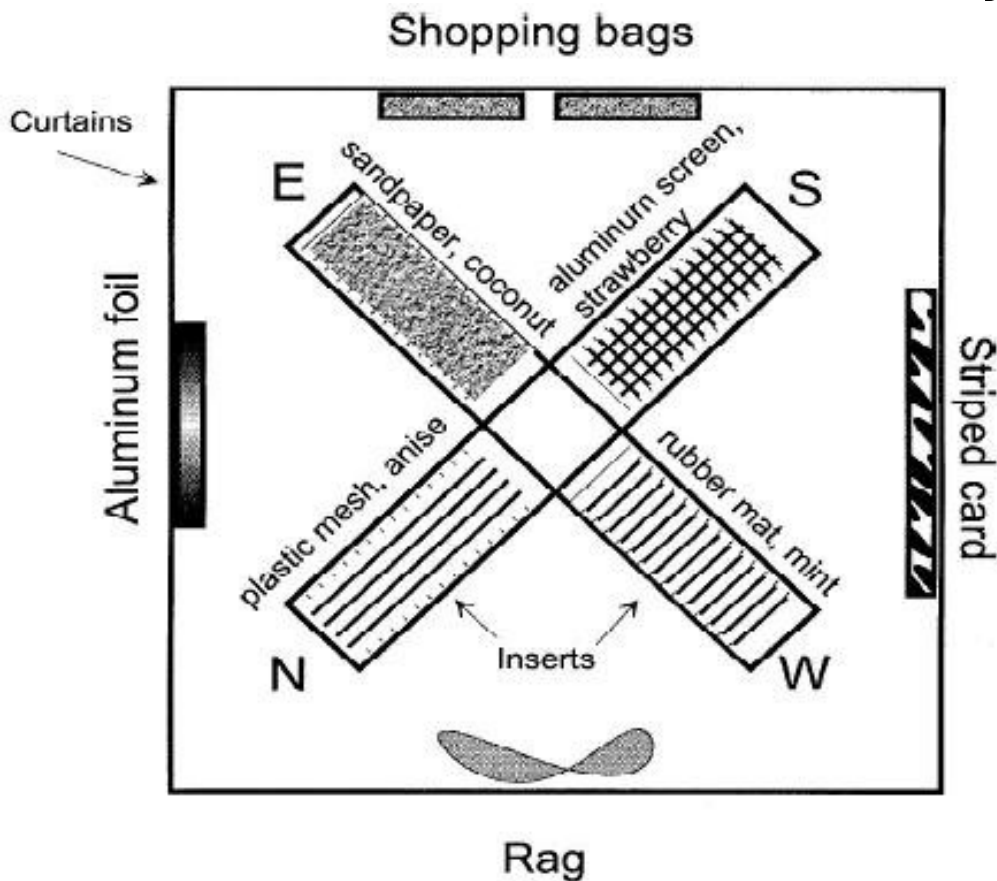

# Does Remapping Matter?

- Masters & Skaggs: remapping coincides with insight into a task:

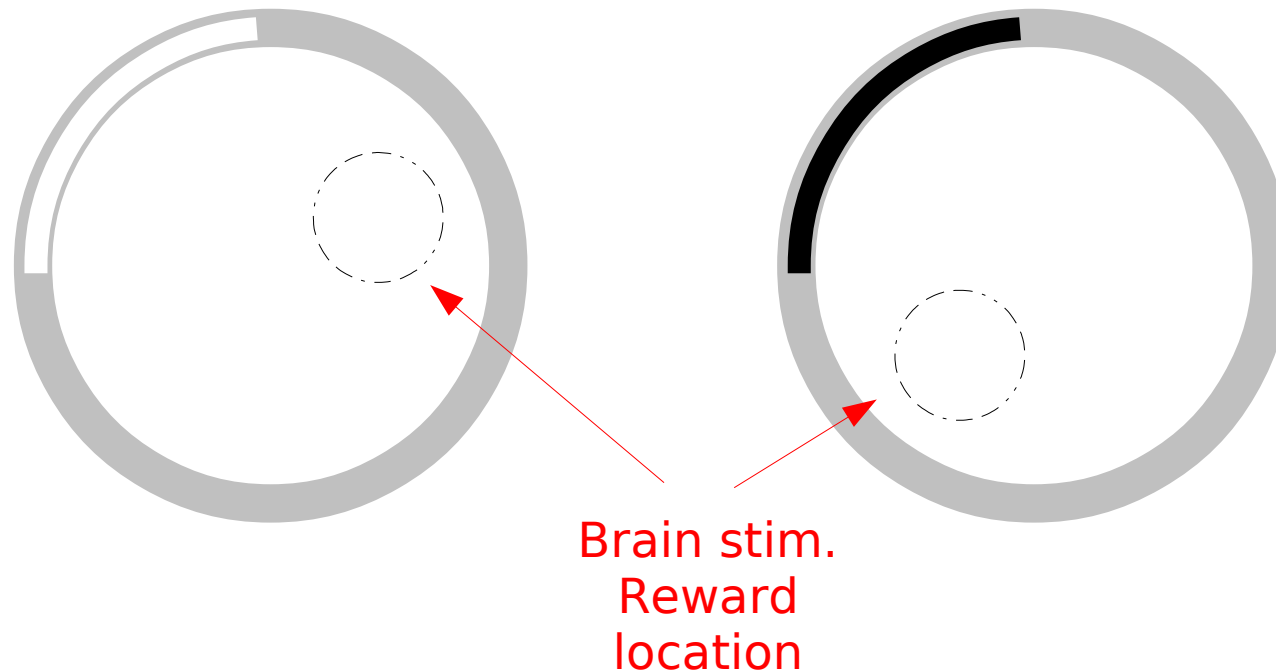

- One rat quickly remapped & learned the task; one never did. One rat didn't remap until day 11, when it suddenly “got” the task. Cause or effect?

# Theta vs Replay Sequences

## Theta

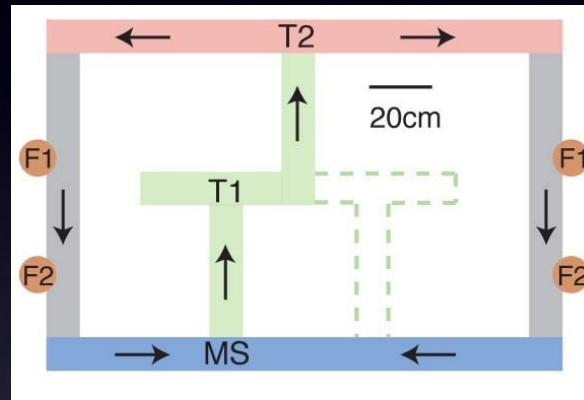
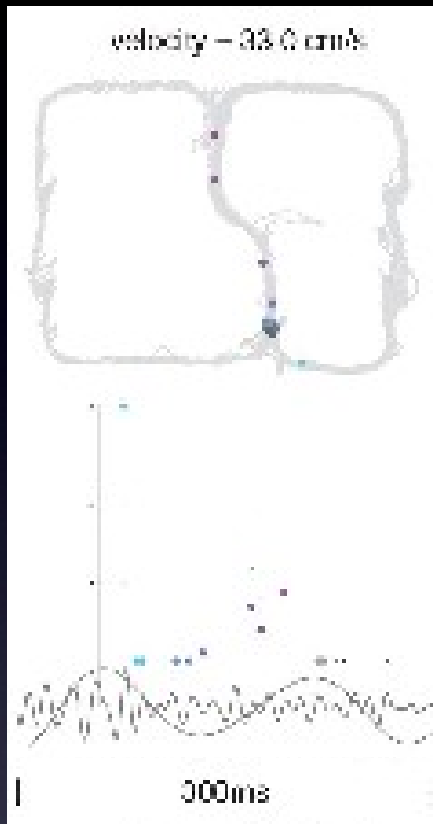

- Occur during attentive behavior
- Theta oscillation is present
- Tied to the animal's location
- Forward sequence
- Few neurons are active
- Relatively short paths represented
- Experience encoding and recall

## Replay

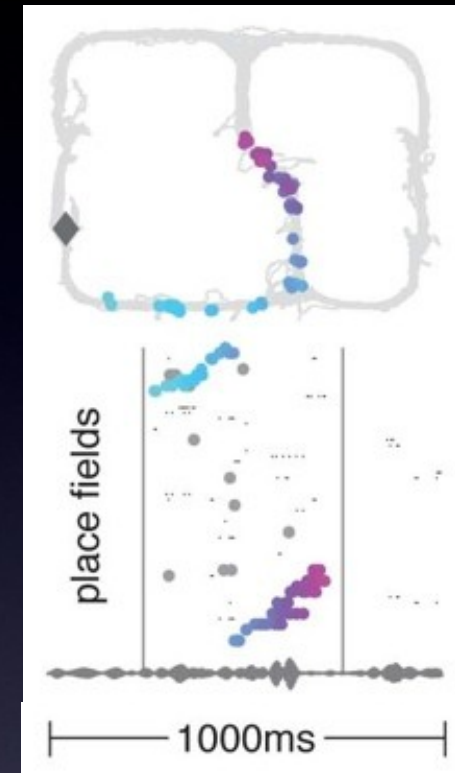

- Occur during awake rest
- Sharp wave ripples present
- Not always tied to the animal's location
- Forward or backward sequence
- Many neurons are often active
- Highly variable path lengths represented
- Memory consolidation, learning of cognitive maps

# Forward Replay

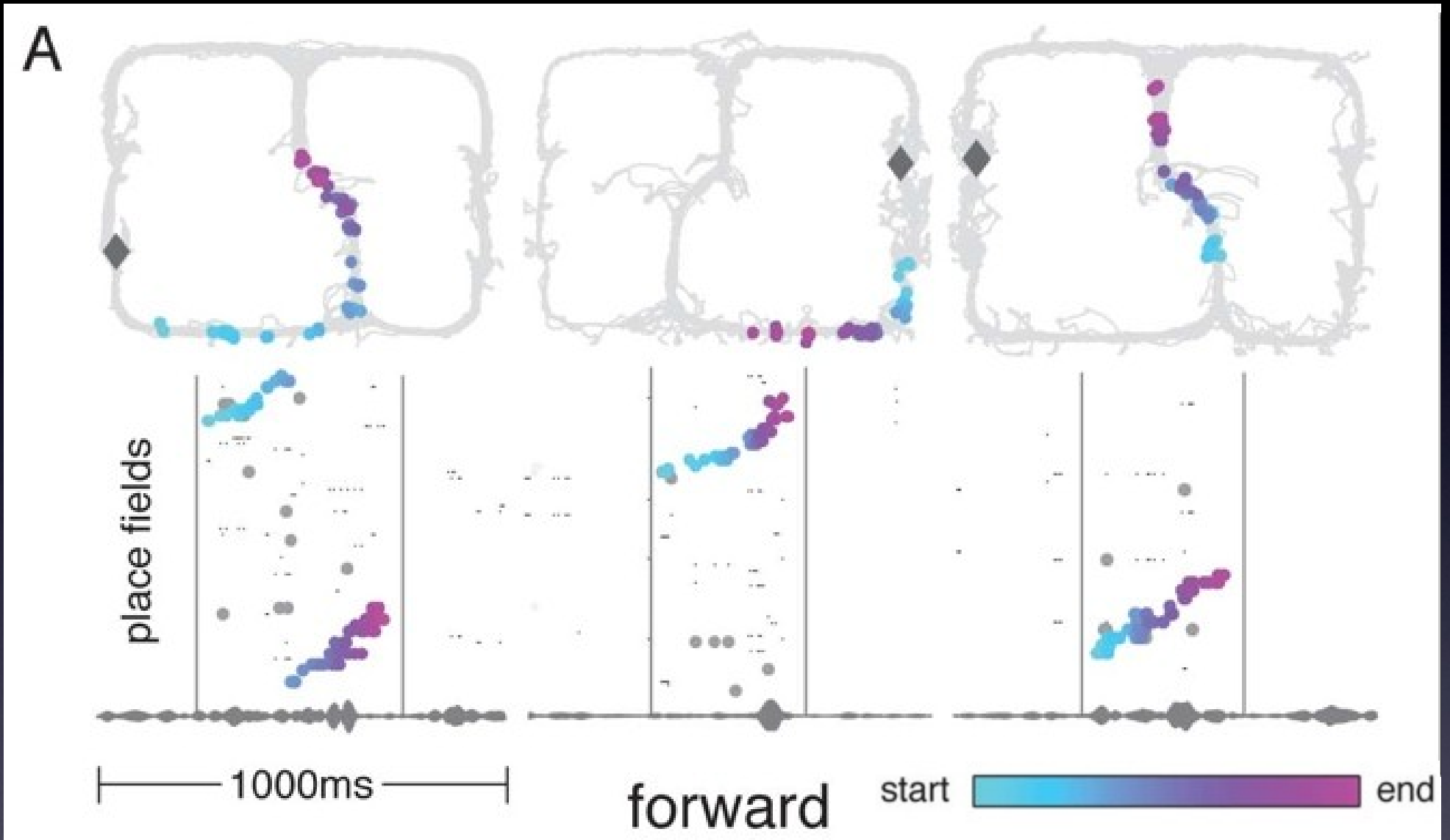

Gupta, van der Meer, Touretzky, Redish, 2010



# Backward Replay

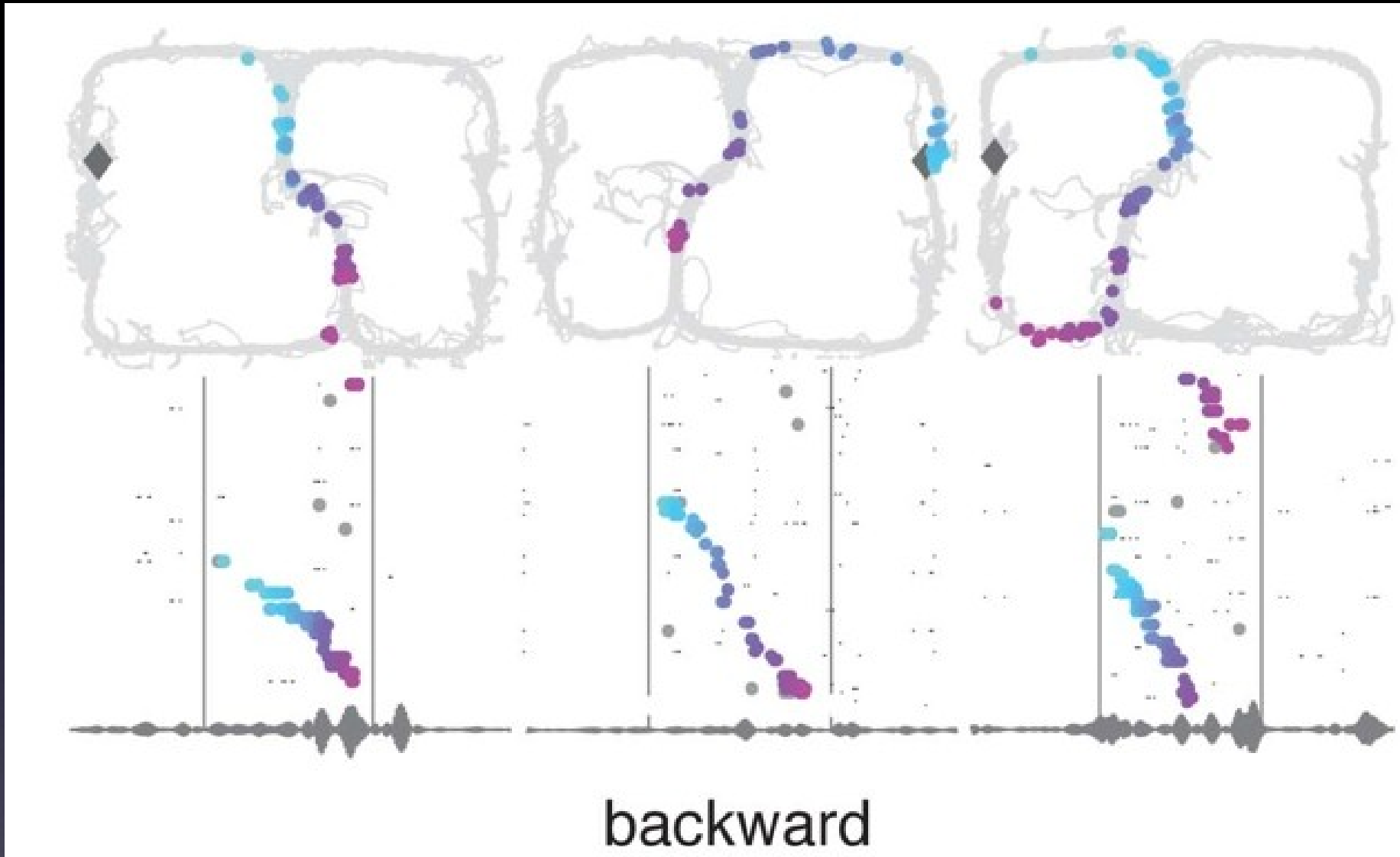

Gupta, van der Meer, Touretzky, Redish, 2010

# Configural Learning

- Sutherland and Rudy suggested that hippocampus learns complex configurations of cues.
- After lesion, animals can still do tasks that depend on only one cue at a time.
- But tasks that depend on *relationships* among cues are impaired. Examples:
  - eight-arm radial maze
  - Morris water maze

# Spatial Working Memory

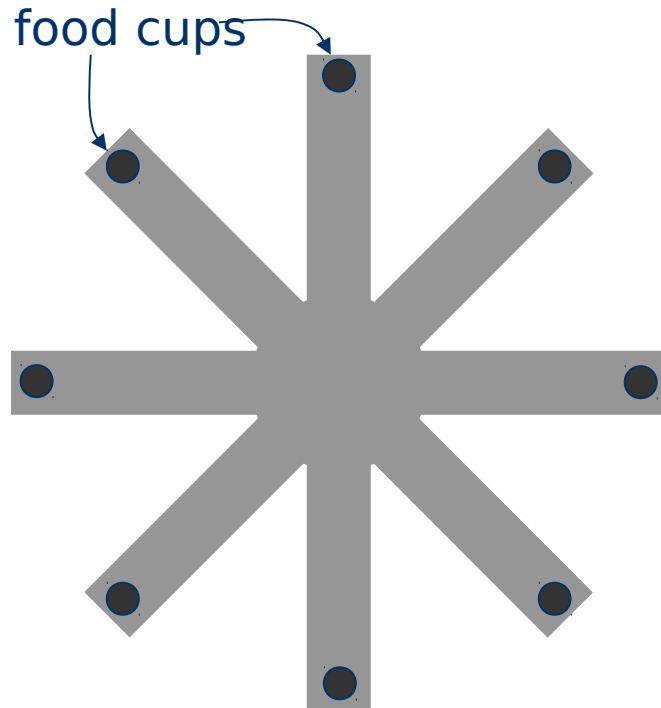

- Apparatus: 8-arm radial maze with food cups at each arm end
- All food cups are baited at the beginning of each trial
- During each trial, rats must remember which arms have already been visited. *A second arm visit provides no reward.*
- Rats with hippocampal lesions are severely impaired at this task (Neave et al., 1997)

# Morris Water Maze

- Large pool filled with milky (opaque), cold water.
- A submerged platform is located at a fixed position in the pool.
- Distal landmarks outside the pool are located around the room; they never move.
- The rat is released from a random starting position and must swim to the platform to get out of the water.

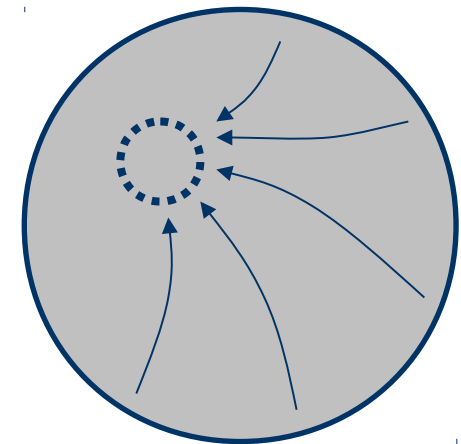
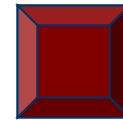

# Morris Water Maze

Sutherland and Rudy  
(1988):

- Rats with fornix lesions can still navigate to a visible platform.
- But they are impaired at learning to find the hidden platform.
- Finding the hidden platform presumably requires recognizing a *configuration* of cues.

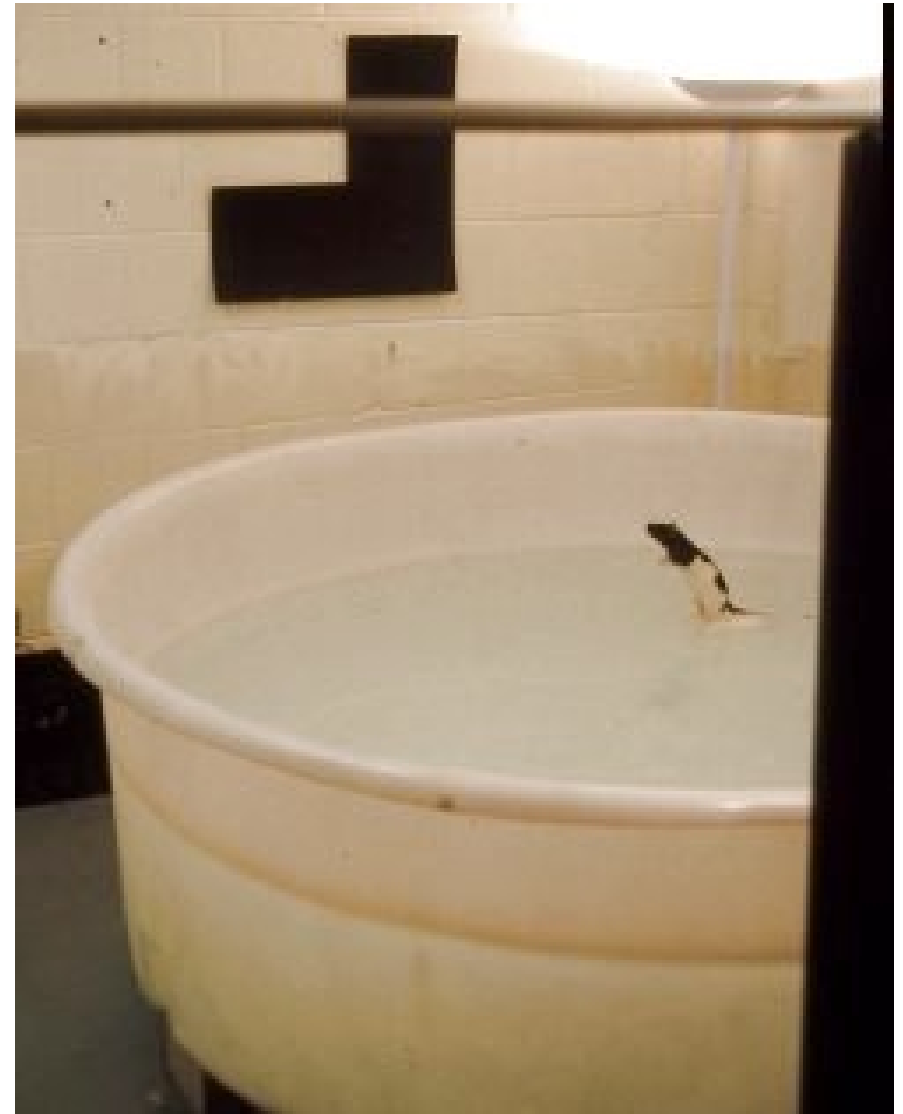



# Morris Water Maze Revisited

- Rats with 48 training trials prior to lesioning the hippocampus showed no deficit (Morris *et al.*, 1990).

## **Hippocampal lesion causes a *learning* deficit!**

- Lesioned rats can gradually learn to find a hidden platform using successively smaller platforms (Schallert *et al.*, 1996):



**Hippocampal lesions cause impairment only when learning the whole path at once!**

# Sequence Learning

## Sequence presentation

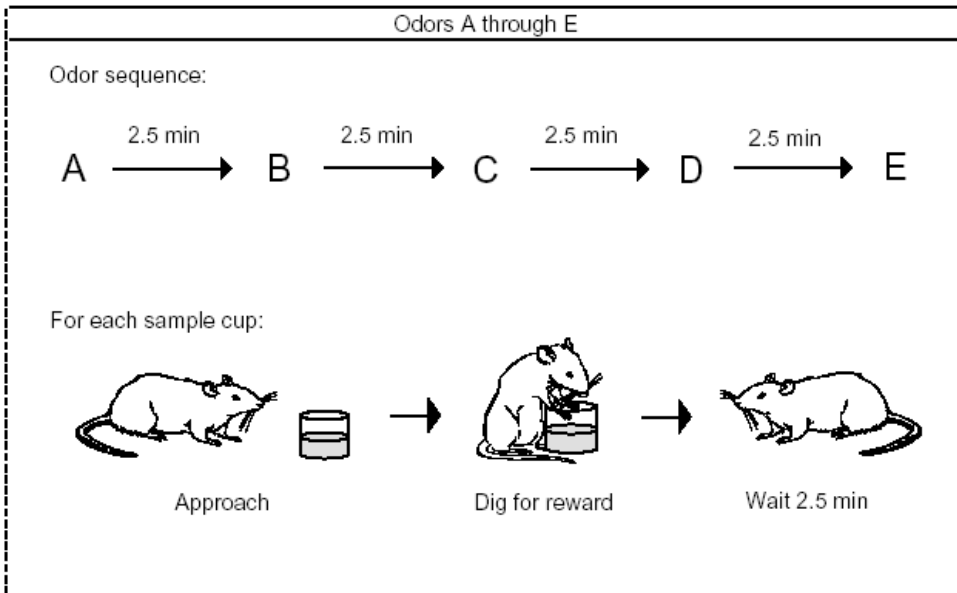

3 min

## Probe

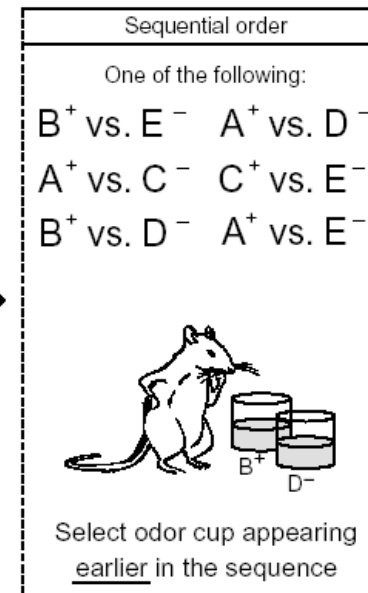

OR

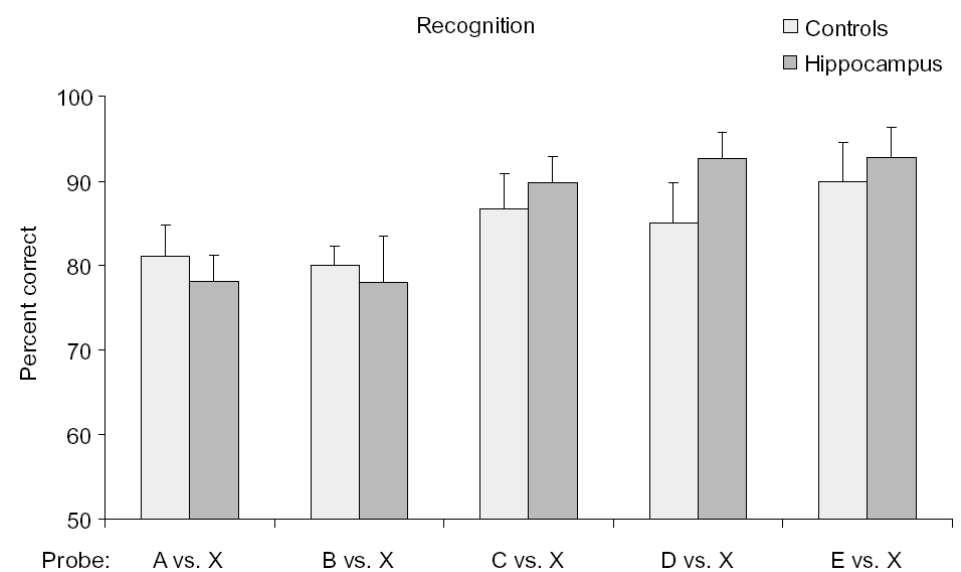
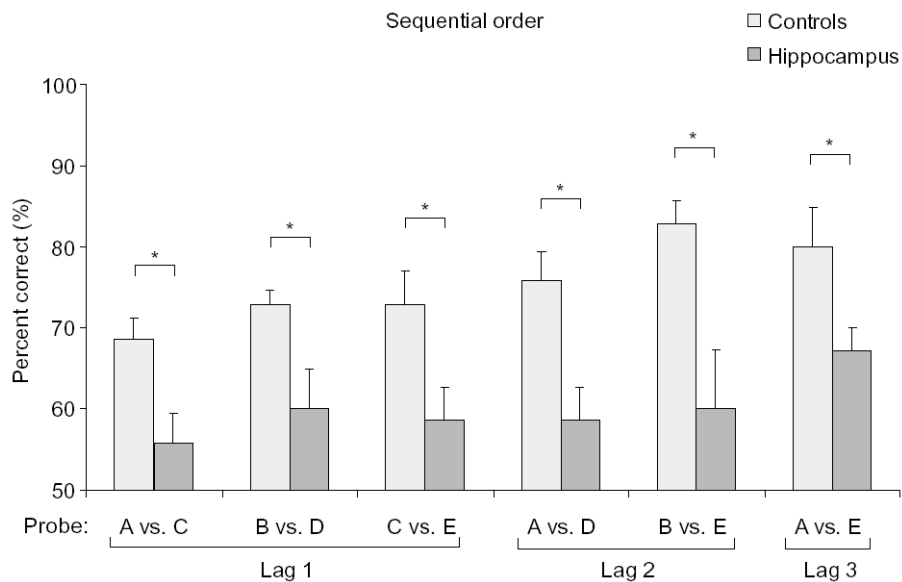
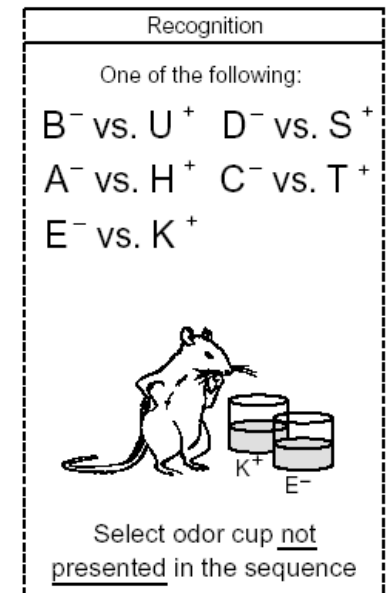

# What Does the Hippocampus Do?

- Builds sparse random representations of complex configurations of sensory and behavioral information.
- Learns spatiotemporal associations between these, within appropriate context, e.g., for:
  - Learning paths to a goal
  - Learning odor sequences
- Retains representations for later use / consolidation.
  - Replay of paths during sleep
  - Recall of task state after delay:
    - DMS and DNMS tasks
    - Trace conditioning