

# Bits, Bytes, and Integers

15-213: Introduction to Computer Systems  
2<sup>nd</sup> and 3<sup>rd</sup> Lectures, Jan 19 and Jan 24, 2012

**Instructors:**

Todd C. Mowry & Anthony Rowe

# Today: Bits, Bytes, and Integers

- **Representing information as bits**
- **Bit-level manipulations**
- **Integers**
  - Representation: unsigned and signed
  - Conversion, casting
  - Expanding, truncating
  - Addition, negation, multiplication, shifting
  - Summary
- **Representations in memory, pointers, strings**

# Binary Representations

## ■ Base 2 Number Representation

- Represent  $15213_{10}$  as  $11101101101101_2$
- Represent  $1.20_{10}$  as  $1.0011001100110011[0011]..._2$
- Represent  $1.5213 \times 10^4$  as  $1.1101101101101_2 \times 2^{13}$

## ■ Electronic Implementation

- Easy to store with bistable elements
- Reliably transmitted on noisy and inaccurate wires

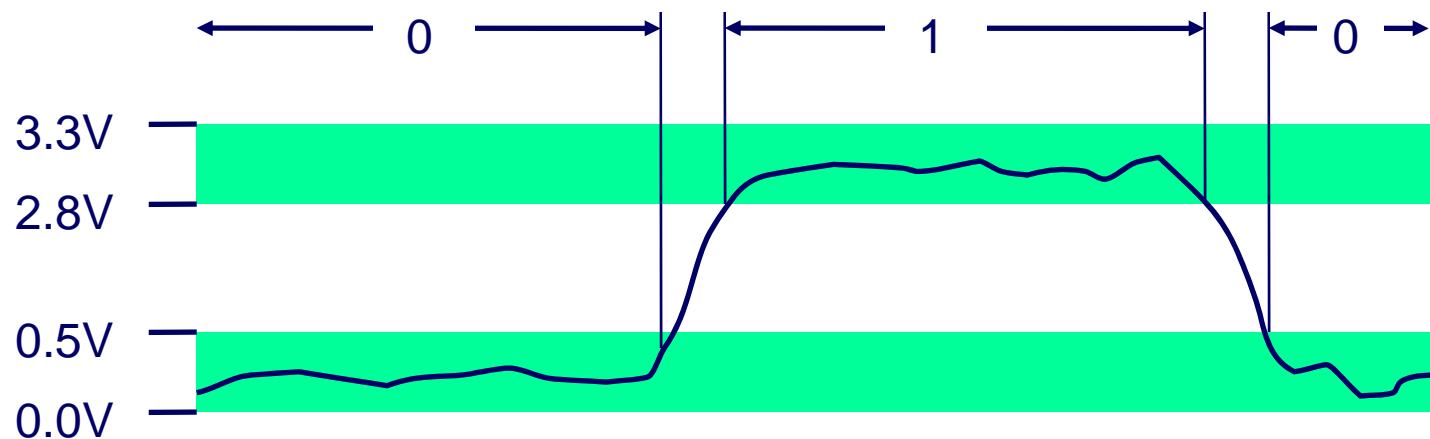

# Encoding Byte Values

## ■ Byte = 8 bits

- Binary  $00000000_2$  to  $11111111_2$
- Decimal:  $0_{10}$  to  $255_{10}$
- Hexadecimal  $00_{16}$  to  $FF_{16}$ 
  - Base 16 number representation
  - Use characters '0' to '9' and 'A' to 'F'
  - Write  $FA1D37B_{16}$  in C as
    - `0xFA1D37B`
    - `0xfa1d37b`

Hex	Decimal	Binary
0	0	0000
1	1	0001
2	2	0010
3	3	0011
4	4	0100
5	5	0101
6	6	0110
7	7	0111
8	8	1000
9	9	1001
A	10	1010
B	11	1011
C	12	1100
D	13	1101
E	14	1110
F	15	1111

# Data Representations

C Data Type	Typical 32-bit	Intel IA32	x86-64
char	1	1	1
short	2	2	2
int	4	4	4
long	4	4	8
long long	8	8	8
float	4	4	4
double	8	8	8
long double	8	10/12	10/16
pointer	4	4	8

# Today: Bits, Bytes, and Integers

- Representing information as bits
- **Bit-level manipulations**
- Integers
  - Representation: unsigned and signed
  - Conversion, casting
  - Expanding, truncating
  - Addition, negation, multiplication, shifting
  - Summary
- Representations in memory, pointers, strings

# Boolean Algebra

- **Developed by George Boole in 19th Century**

- Algebraic representation of logic
  - Encode “True” as 1 and “False” as 0

## And

- $A \& B = 1$  when both  $A=1$  and  $B=1$

$\&$	0	1
0	0	0
1	0	1

## Or

- $A | B = 1$  when either  $A=1$  or  $B=1$

	0	1
0	0	1
1	1	1

## Not

- $\sim A = 1$  when  $A=0$

$\sim$	
0	1
1	0

## Exclusive-Or (Xor)

- $A \wedge B = 1$  when either  $A=1$  or  $B=1$ , but not both

$\wedge$	0	1
0	0	1
1	1	0

# General Boolean Algebras

- Operate on Bit Vectors

- Operations applied bitwise

$$\begin{array}{cccc}
 01101001 & 01101001 & 01101001 & 01101001 \\
 \& \underline{01010101} & | \underline{01010101} & ^ \underline{01010101} & \sim \underline{01010101} \\
 01000001 & 01111101 & 00111100 & 10101010
 \end{array}$$

- All of the Properties of Boolean Algebra Apply



# Example: Representing & Manipulating Sets

## ■ Representation

- Width  $w$  bit vector represents subsets of  $\{0, \dots, w-1\}$
- $a_j = 1$  if  $j \in A$

- 01101001      { 0, 3, 5, 6 }

- 76543210

- 01010101      { 0, 2, 4, 6 }

- 76543210

## ■ Operations

- & Intersection      01000001      { 0, 6 }
- | Union      01111101      { 0, 2, 3, 4, 5, 6 }
- ^ Symmetric difference      00111100      { 2, 3, 4, 5 }
- ~ Complement      10101010      { 1, 3, 5, 7 }

# Bit-Level Operations in C

## ■ Operations $\&$ , $|$ , $\sim$ , $\wedge$ Available in C

- Apply to any “integral” data type
  - long, int, short, char, unsigned
- View arguments as bit vectors
- Arguments applied bit-wise

## ■ Examples (Char data type)

- $\sim 0x41 \rightarrow 0xBE$ 
  - $\sim 01000001_2 \rightarrow 10111110_2$
- $\sim 0x00 \rightarrow 0xFF$ 
  - $\sim 00000000_2 \rightarrow 11111111_2$
- $0x69 \& 0x55 \rightarrow 0x41$ 
  - $01101001_2 \& 01010101_2 \rightarrow 01000001_2$
- $0x69 | 0x55 \rightarrow 0x7D$ 
  - $01101001_2 | 01010101_2 \rightarrow 01111101_2$

# Contrast: Logic Operations in C

## ■ Contrast to Logical Operators

- `&&`, `||`, `!`
  - View 0 as “False”
  - Anything nonzero as “True”
  - Always return 0 or 1
  - **Early termination**

## ■ Examples (char data type)

- `!0x41` → `0x00`
- `!0x00` → `0x01`
- `!!0x41` → `0x01`
  
- `0x69 && 0x55` → `0x01`
- `0x69 || 0x55` → `0x01`
- `p && *p` (avoids null pointer access)

# Contrast: Logic Operations in C

## ■ Contrast to Logical Operators

- `&&`, `||`, `!`
  - View 0 as “False”
  - Anything nonzero as “True”
  - Always return 0 or 1
  - **Early termination**

Watch out for `&&` vs. `&` (and `||` vs. `|`)... one of the more common oopsies in C programming

## ■ Examples (char data type)

- `!0x41` → `0x00`
- `!0x00` → `0x01`
- `!!0x41` → `0x01`
  
- `0x69 && 0x55` → `0x01`
- `0x69 || 0x55` → `0x01`
- `p && *p` (avoids null pointer access)

# Shift Operations

- **Left Shift:  $x \ll y$** 
  - Shift bit-vector  $x$  left  $y$  positions
    - Throw away extra bits on left
    - Fill with 0's on right
- **Right Shift:  $x \gg y$** 
  - Shift bit-vector  $x$  right  $y$  positions
    - Throw away extra bits on right
  - Logical shift
    - Fill with 0's on left
  - Arithmetic shift
    - Replicate most significant bit on left
- **Undefined Behavior**
  - Shift amount  $< 0$  or  $\geq$  word size

<b>Argument <math>x</math></b>	01100010
$\ll 3$	00010000
<b>Log. <math>\gg 2</math></b>	00011000
<b>Arith. <math>\gg 2</math></b>	00011000

<b>Argument <math>x</math></b>	10100010
$\ll 3$	00010000
<b>Log. <math>\gg 2</math></b>	00101000
<b>Arith. <math>\gg 2</math></b>	11101000

# Today: Bits, Bytes, and Integers

- Representing information as bits
- Bit-level manipulations
- **Integers**
  - **Representation: unsigned and signed**
  - Conversion, casting
  - Expanding, truncating
  - Addition, negation, multiplication, shifting
  - Summary
- Representations in memory, pointers, strings
- Summary

# Encoding Integers

## Unsigned

$$B2U(X) = \sum_{i=0}^{w-1} x_i \cdot 2^i$$

## Two's Complement

$$B2T(X) = -x_{w-1} \cdot 2^{w-1} + \sum_{i=0}^{w-2} x_i \cdot 2^i$$

```
short int x = 15213;
short int y = -15213;
```

Sign  
Bit



## ■ C short 2 bytes long

	Decimal	Hex	Binary
<b>x</b>	15213	3B 6D	00111011 01101101
<b>y</b>	-15213	C4 93	11000100 10010011

## ■ Sign Bit

- For 2's complement, most significant bit indicates sign
  - 0 for nonnegative
  - 1 for negative

# Encoding Example (Cont.)

```

x =      15213: 00111011 01101101
y =     -15213: 11000100 10010011
  
```

Weight	15213		-15213	
1	1	1	1	1
2	0	0	1	2
4	1	4	0	0
8	1	8	0	0
16	0	0	1	16
32	1	32	0	0
64	1	64	0	0
128	0	0	1	128
256	1	256	0	0
512	1	512	0	0
1024	0	0	1	1024
2048	1	2048	0	0
4096	1	4096	0	0
8192	1	8192	0	0
16384	0	0	1	16384
-32768	0	0	1	-32768
<b>Sum</b>	<b>15213</b>		<b>-15213</b>	



# Numeric Ranges

## ■ Unsigned Values

- $UMin = 0$   
000...0
- $UMax = 2^w - 1$   
111...1

## ■ Two's Complement Values

- $TMin = -2^{w-1}$   
100...0
- $TMax = 2^{w-1} - 1$   
011...1

## ■ Other Values

- Minus 1  
111...1

### Values for $W = 16$

	Decimal	Hex	Binary
<b>UMax</b>	<b>65535</b>	<b>FF FF</b>	<b>11111111 11111111</b>
<b>TMax</b>	<b>32767</b>	<b>7F FF</b>	<b>01111111 11111111</b>
<b>TMin</b>	<b>-32768</b>	<b>80 00</b>	<b>10000000 00000000</b>
<b>-1</b>	<b>-1</b>	<b>FF FF</b>	<b>11111111 11111111</b>
<b>0</b>	<b>0</b>	<b>00 00</b>	<b>00000000 00000000</b>

# Values for Different Word Sizes

	W			
	8	16	32	64
<b>UMax</b>	255	65,535	4,294,967,295	18,446,744,073,709,551,615
<b>TMax</b>	127	32,767	2,147,483,647	9,223,372,036,854,775,807
<b>TMin</b>	-128	-32,768	-2,147,483,648	-9,223,372,036,854,775,808

## ■ Observations

- $|TMin| = TMax + 1$ 
  - Asymmetric range
- $UMax = 2 * TMax + 1$

## ■ C Programming

- `#include <limits.h>`
- Declares constants, e.g.,
  - `ULONG_MAX`
  - `LONG_MAX`
  - `LONG_MIN`
- Values platform specific

# Unsigned & Signed Numeric Values

$X$	$B2U(X)$	$B2T(X)$
0000	0	0
0001	1	1
0010	2	2
0011	3	3
0100	4	4
0101	5	5
0110	6	6
0111	7	7
1000	8	-8
1001	9	-7
1010	10	-6
1011	11	-5
1100	12	-4
1101	13	-3
1110	14	-2
1111	15	-1

## ■ Equivalence

- Same encodings for nonnegative values

## ■ Uniqueness

- Every bit pattern represents unique integer value
- Each representable integer has unique bit encoding

## ■ $\Rightarrow$ Can Invert Mappings

- $U2B(x) = B2U^{-1}(x)$ 
  - Bit pattern for unsigned integer
- $T2B(x) = B2T^{-1}(x)$ 
  - Bit pattern for two's comp integer

# Today: Bits, Bytes, and Integers

- Representing information as bits
- Bit-level manipulations
- **Integers**
  - Representation: unsigned and signed
  - **Conversion, casting**
  - Expanding, truncating
  - Addition, negation, multiplication, shifting
  - Summary
- Representations in memory, pointers, strings

# Mapping Between Signed & Unsigned

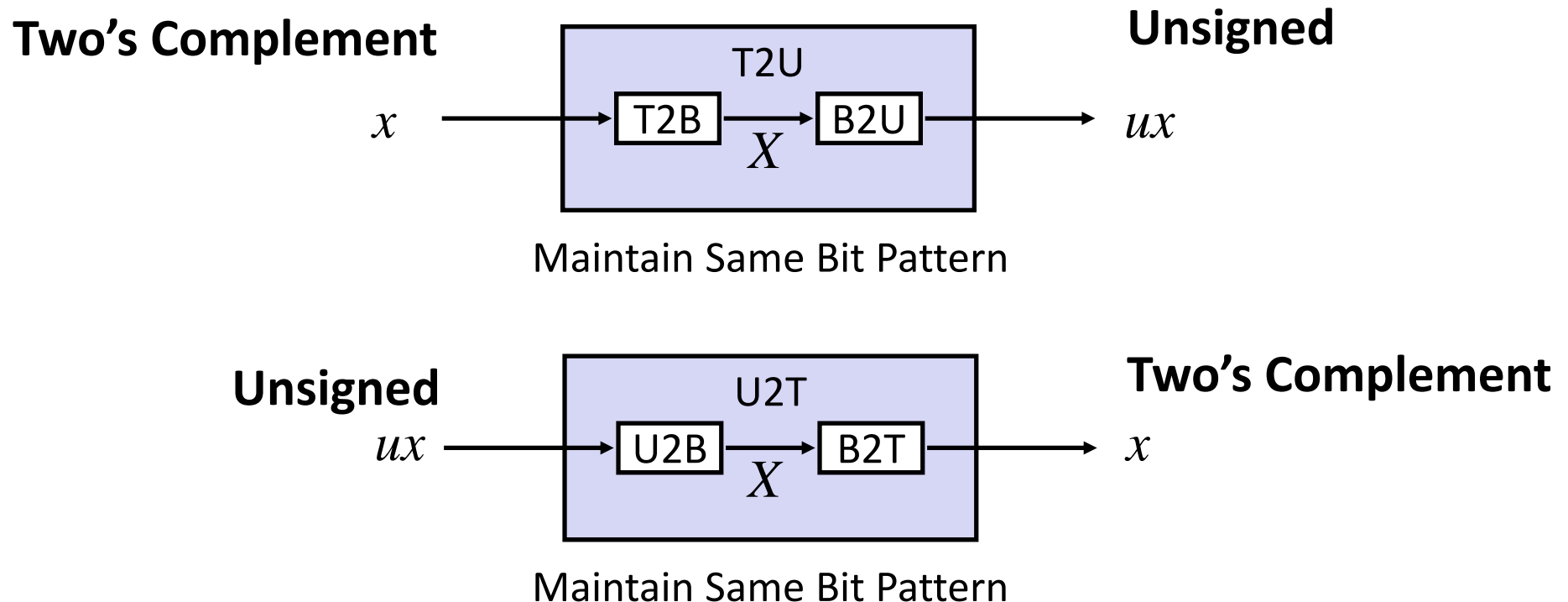

- Mappings between unsigned and two's complement numbers:  
**keep bit representations and reinterpret**

# Mapping Signed $\leftrightarrow$ Unsigned

Bits	Signed		Unsigned
0000	0		0
0001	1		1
0010	2		2
0011	3		3
0100	4		4
0101	5		5
0110	6		6
0111	7		7
1000	-8	→ T2U →	8
1001	-7		9
1010	-6		10
1011	-5		11
1100	-4		12
1101	-3		13
1110	-2		14
1111	-1	← U2T ←	15

# Mapping Signed $\leftrightarrow$ Unsigned

Bits	Signed	Unsigned
0000	0	0
0001	1	1
0010	2	2
0011	3	3
0100	4	4
0101	5	5
0110	6	6
0111	7	7
1000	-8	8
1001	-7	9
1010	-6	10
1011	-5	11
1100	-4	12
1101	-3	13
1110	-2	14
1111	-1	15

← = →

← +/- 16 →

# Relation between Signed & Unsigned

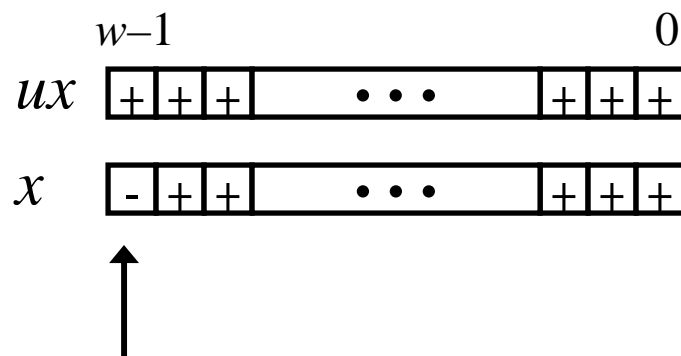
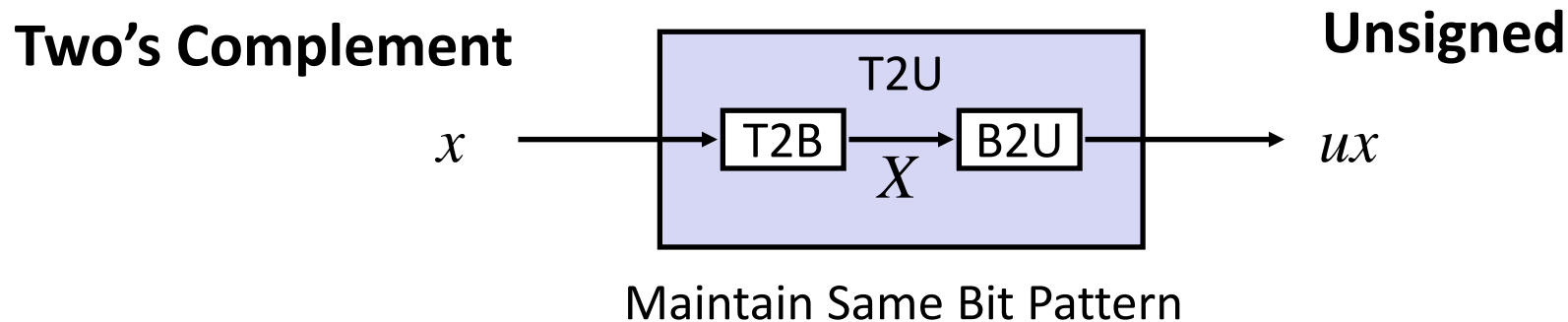

**Large negative weight**  
*becomes*  
**Large positive weight**



# Conversion Visualized

## ■ 2's Comp. → Unsigned

- Ordering Inversion
- Negative → Big Positive

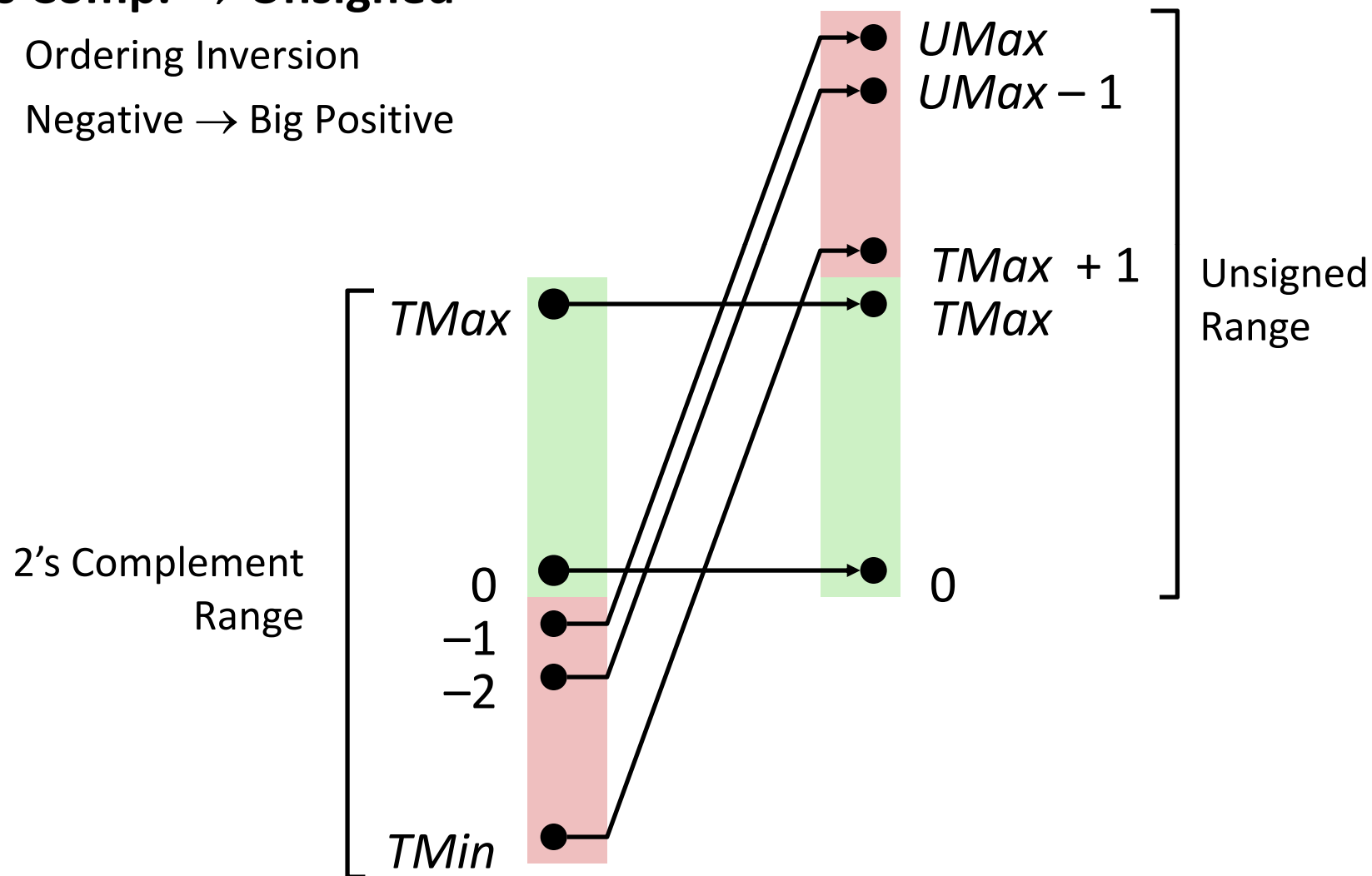

# Signed vs. Unsigned in C

## ■ Constants

- By default are considered to be signed integers
- Unsigned if have “U” as suffix

`0U, 4294967259U`

## ■ Casting

- Explicit casting between signed & unsigned same as U2T and T2U

```
int tx, ty;
unsigned ux, uy;
tx = (int) ux;
uy = (unsigned) ty;
```

- Implicit casting also occurs via assignments and procedure calls

```
tx = ux;
uy = ty;
```

# Casting Surprises

## ■ Expression Evaluation

- If there is a mix of unsigned and signed in single expression, *signed values implicitly cast to unsigned*
- Including comparison operations  $<$ ,  $>$ ,  $==$ ,  $<=$ ,  $>=$
- Examples for  $W = 32$ : **TMIN = -2,147,483,648**, **TMAX = 2,147,483,647**

■ Constant <sub>1</sub>	Constant <sub>2</sub>	Relation	Evaluation
0	0U	==	unsigned
-1	0	<	signed
-1	0U	>	unsigned
2147483647	-2147483647-1	>	signed
2147483647U	-2147483647-1	<	unsigned
-1	-2	>	signed
(unsigned)-1	-2	>	unsigned
2147483647	2147483648U	<	unsigned
2147483647	(int) 2147483648U	>	signed

# Summary

## Casting Signed $\leftrightarrow$ Unsigned: Basic Rules

- Bit pattern is maintained
- But reinterpreted
- Can have unexpected effects: adding or subtracting  $2^w$
- Expression containing signed and unsigned int
  - `int` is cast to `unsigned`!!

# Today: Bits, Bytes, and Integers

- Representing information as bits
- Bit-level manipulations
- **Integers**
  - Representation: unsigned and signed
  - Conversion, casting
  - **Expanding, truncating**
  - Addition, negation, multiplication, shifting
  - Summary
- Representations in memory, pointers, strings

# Sign Extension

## ■ Task:

- Given  $w$ -bit signed integer  $x$
- Convert it to  $w+k$ -bit integer with same value

## ■ Rule:

- Make  $k$  copies of sign bit:
- $X' = \underbrace{x_{w-1}, \dots, x_{w-1}}_{k \text{ copies of MSB}}, x_{w-1}, x_{w-2}, \dots, x_0$

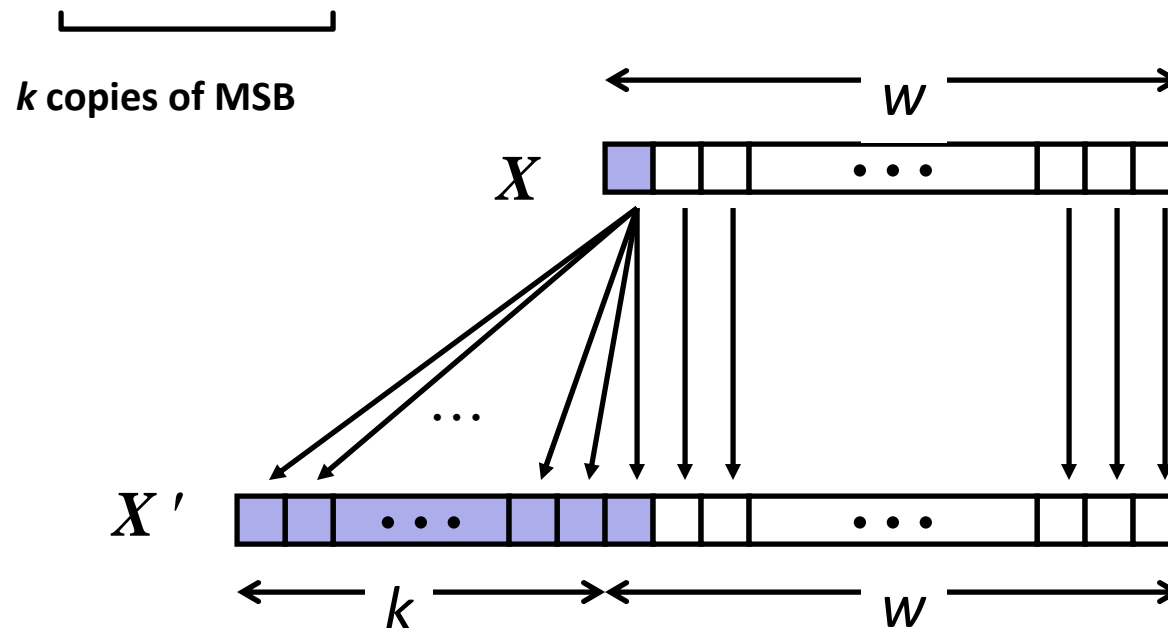

# Sign Extension Example

```
short int x = 15213;
int      ix = (int) x;
short int y = -15213;
int      iy = (int) y;
```

	Decimal	Hex	Binary
<b>x</b>	15213	3B 6D	00111011 01101101
<b>ix</b>	15213	00 00 3B 6D	00000000 00000000 00111011 01101101
<b>y</b>	-15213	C4 93	11000100 10010011
<b>iy</b>	-15213	FF FF C4 93	11111111 11111111 11000100 10010011

- Converting from smaller to larger integer data type
- C automatically performs sign extension

# Summary:

## Expanding, Truncating: Basic Rules

- **Expanding (e.g., short int to int)**
  - Unsigned: zeros added
  - Signed: sign extension
  - Both yield expected result
  
- **Truncating (e.g., unsigned to unsigned short)**
  - Unsigned/signed: bits are truncated
  - Result reinterpreted
  - Unsigned: mod operation
  - Signed: similar to mod
  - For small numbers yields expected behaviour



# Today: Bits, Bytes, and Integers

- Representing information as bits
- Bit-level manipulations
- **Integers**
  - Representation: unsigned and signed
  - Conversion, casting
  - Expanding, truncating
  - **Addition, negation, multiplication, shifting**
- Representations in memory, pointers, strings
- Summary

# Unsigned Addition

Operands:  $w$  bits



True Sum:  $w+1$  bits

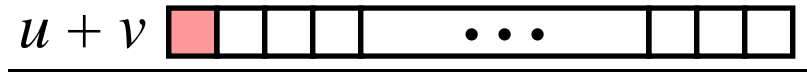

Discard Carry:  $w$  bits



## ■ Standard Addition Function

- Ignores carry output

## ■ Implements Modular Arithmetic

$$s = \text{UAdd}_w(u, v) = u + v \bmod 2^w$$

# Visualizing (Mathematical) Integer Addition

## ■ Integer Addition

- 4-bit integers  $u, v$
- Compute true sum  $\text{Add}_4(u, v)$
- Values increase linearly with  $u$  and  $v$
- Forms planar surface

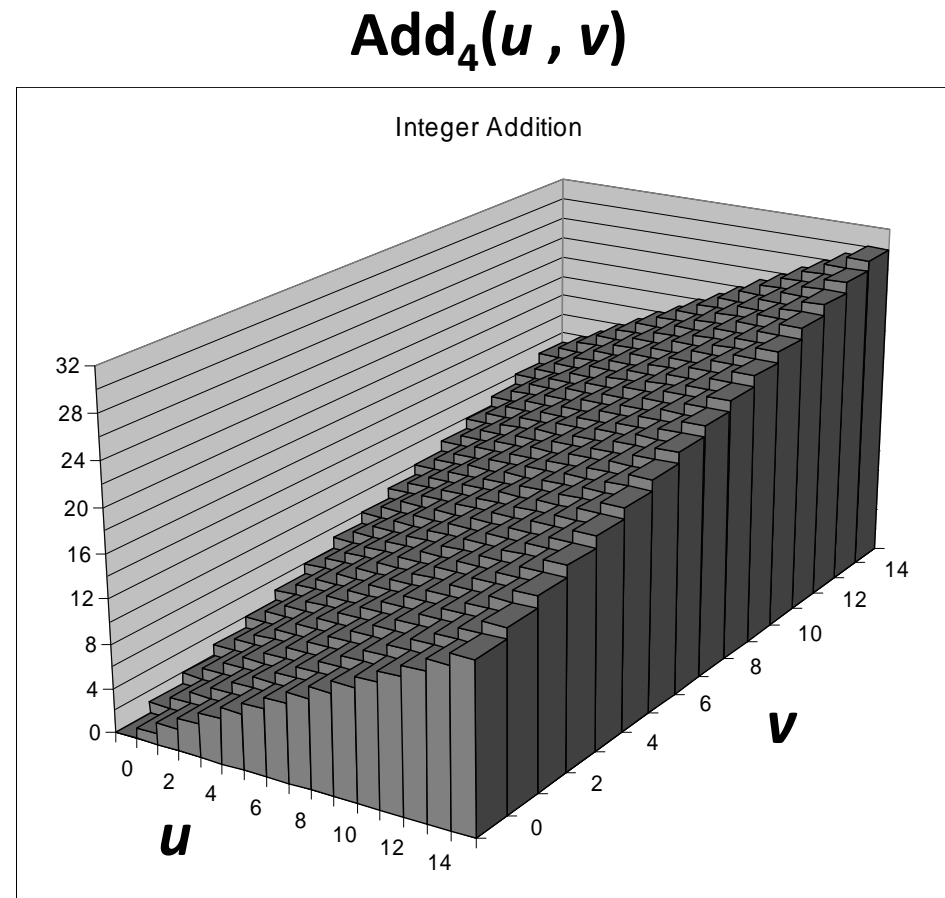

# Visualizing Unsigned Addition

## ■ Wraps Around

- If true sum  $\geq 2^w$
- At most once

True Sum

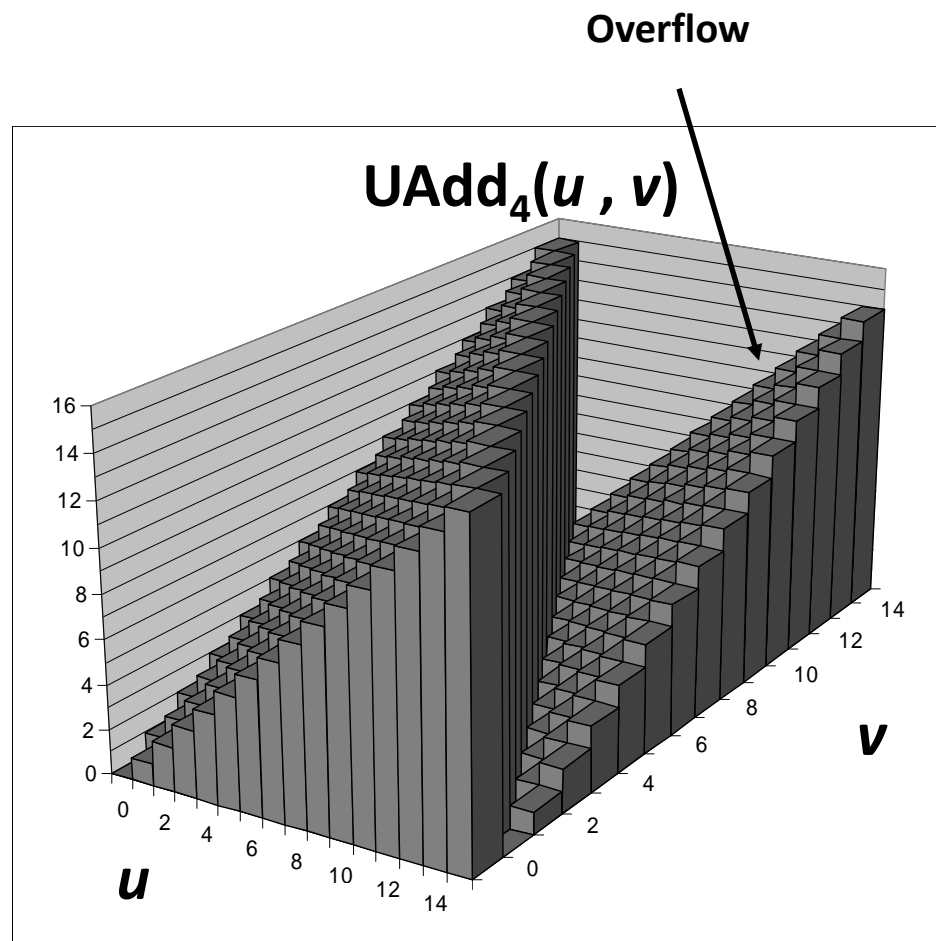
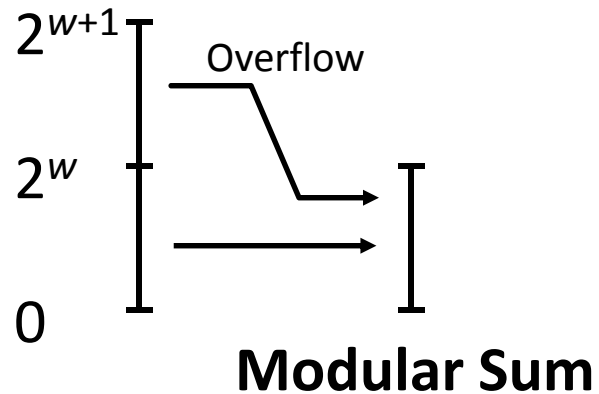

# Two's Complement Addition

Operands:  $w$  bits



True Sum:  $w+1$  bits



Discard Carry:  $w$  bits



## ■ TAdd and UAdd have Identical Bit-Level Behavior

- Signed vs. unsigned addition in C:

```
int s, t, u, v;
```

```
s = (int) ((unsigned) u + (unsigned) v);
```

```
t = u + v
```

- Will give `s == t`

# TAdd Overflow

## ■ Functionality

- True sum requires  $w+1$  bits
- Drop off MSB
- Treat remaining bits as 2's comp. integer

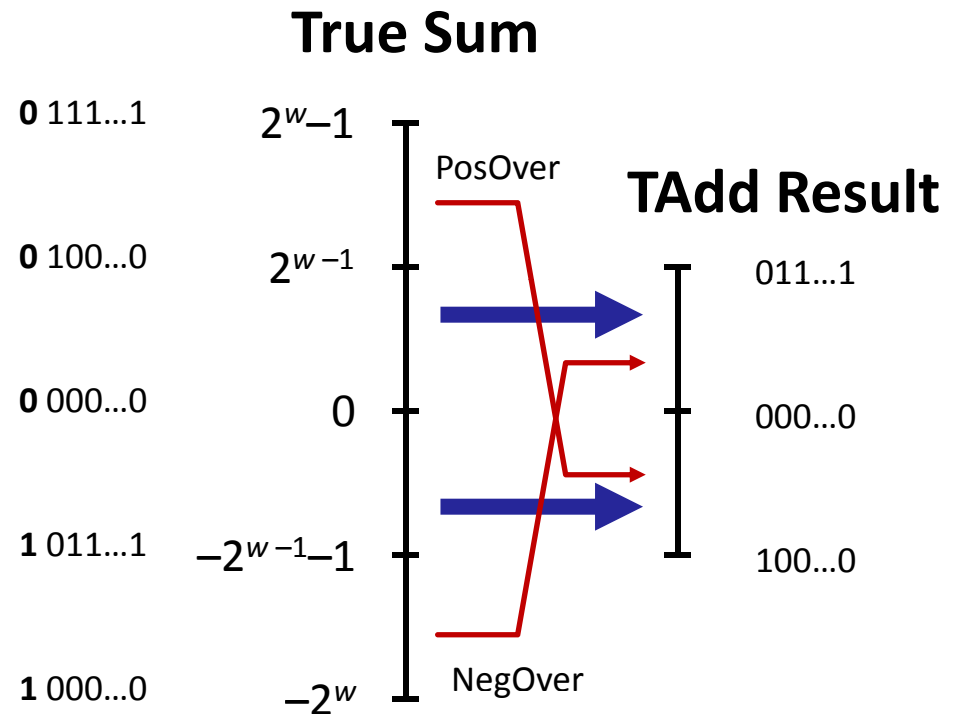

# Visualizing 2's Complement Addition

## ■ Values

- 4-bit two's comp.
- Range from -8 to +7

## ■ Wraps Around

- If  $\text{sum} \geq 2^{w-1}$ 
  - Becomes negative
  - At most once
- If  $\text{sum} < -2^{w-1}$ 
  - Becomes positive
  - At most once

NegOver

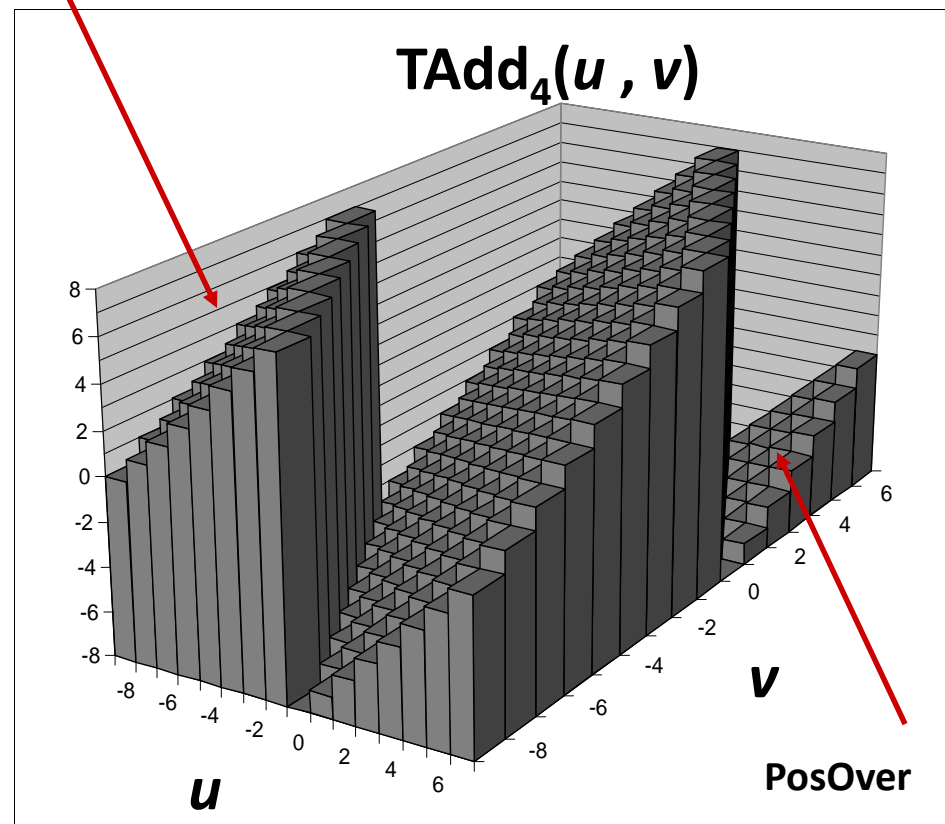

# Multiplication

- **Goal: Computing Product of  $w$ -bit numbers  $x, y$** 
  - Either signed or unsigned
- **But, exact results can be bigger than  $w$  bits**
  - Unsigned: up to  $2w$  bits
    - Result range:  $0 \leq x * y \leq (2^w - 1)^2 = 2^{2w} - 2^{w+1} + 1$
  - Two's complement min (negative): Up to  $2w-1$  bits
    - Result range:  $x * y \geq (-2^{w-1}) * (2^{w-1} - 1) = -2^{2w-2} + 2^{w-1}$
  - Two's complement max (positive): Up to  $2w$  bits, but only for  $(TMin_w)^2$ 
    - Result range:  $x * y \leq (-2^{w-1})^2 = 2^{2w-2}$
- **So, maintaining exact results...**
  - would need to keep expanding word size with each product computed
  - is done in software, if needed
    - e.g., by “arbitrary precision” arithmetic packages



# Unsigned Multiplication in C

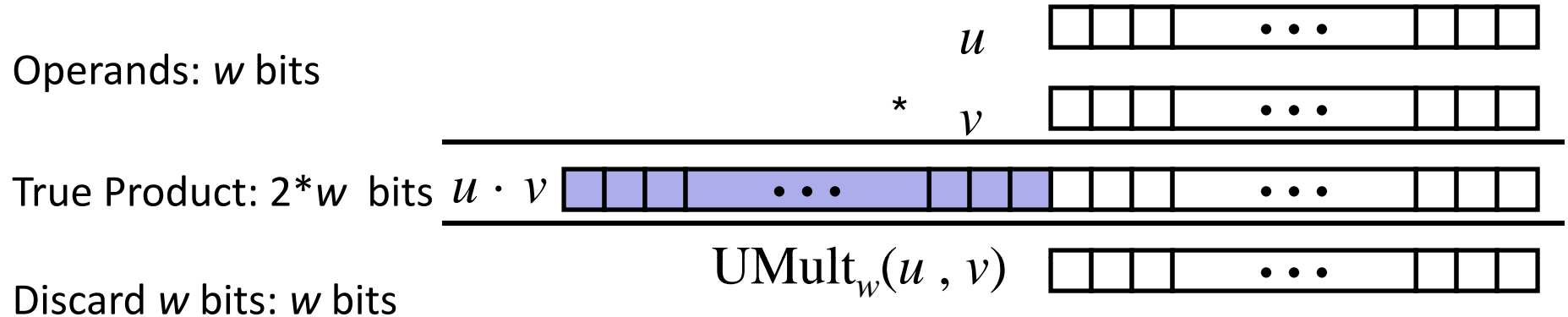

## ■ Standard Multiplication Function

- Ignores high order  $w$  bits

## ■ Implements Modular Arithmetic

$$\text{UMult}_w(u, v) = u \cdot v \bmod 2^w$$

# Signed Multiplication in C

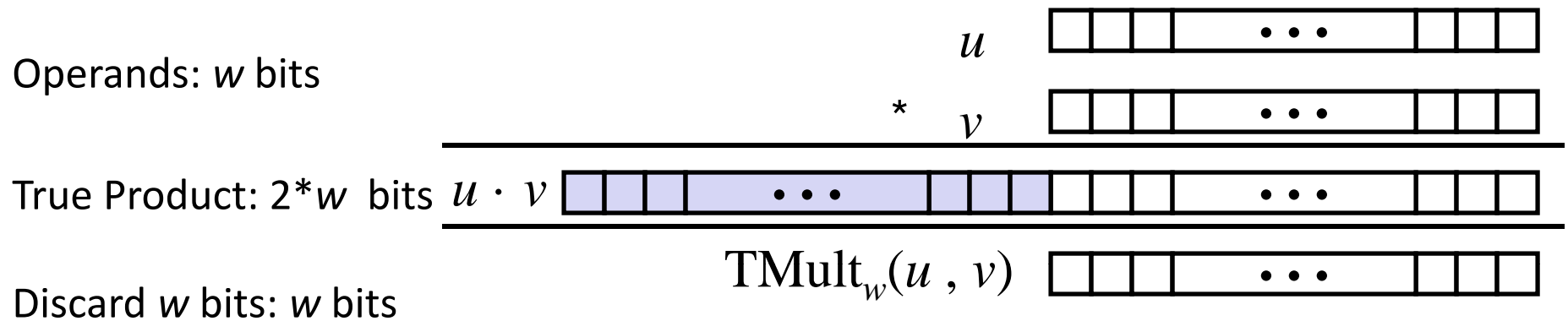

## ■ Standard Multiplication Function

- Ignores high order  $w$  bits
- Some of which are different for signed vs. unsigned multiplication
- Lower bits are the same

# Power-of-2 Multiply with Shift

## ■ Operation

- $u \ll k$  gives  $u * 2^k$
- Both signed and unsigned

Operands:  $w$  bits

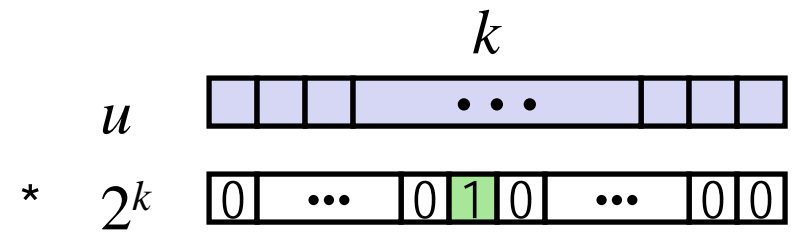

True Product:  $w+k$  bits



Discard  $k$  bits:  $w$  bits

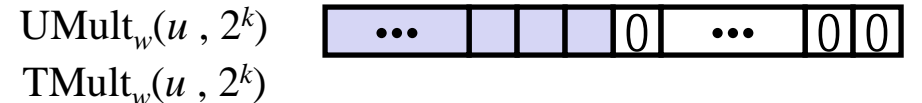

## ■ Examples

- $u \ll 3 \quad == \quad u * 8$
- $u \ll 5 - u \ll 3 \quad == \quad u * 24$
- Most machines shift and add faster than multiply
  - Compiler generates this code automatically

# Unsigned Power-of-2 Divide with Shift

## ■ Quotient of Unsigned by Power of 2

- $u \gg k$  gives  $\lfloor u / 2^k \rfloor$
- Uses logical shift

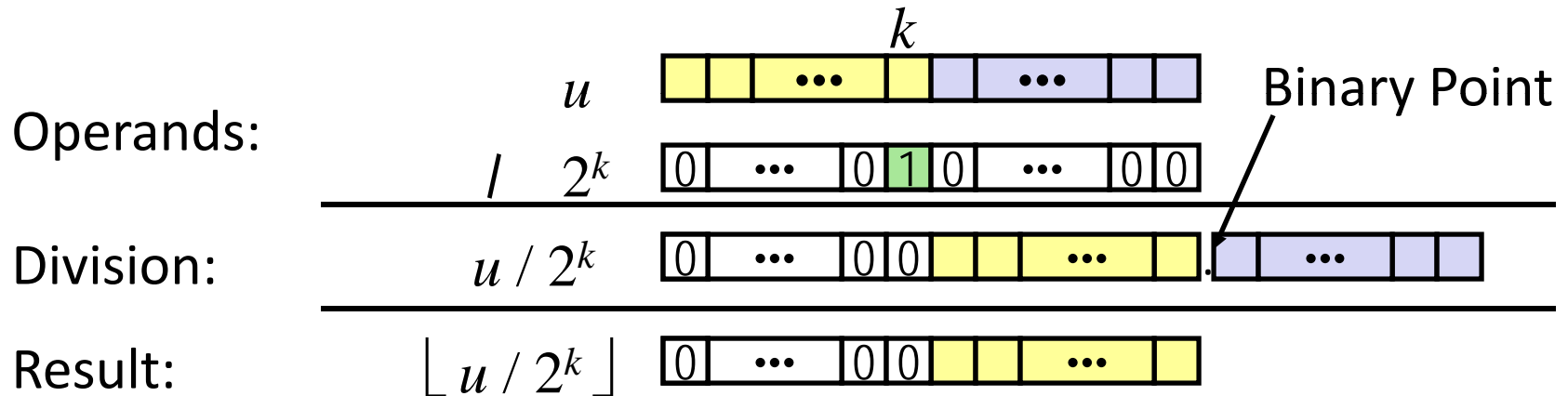

	Division	Computed	Hex	Binary
<b>x</b>	<b>15213</b>	<b>15213</b>	<b>3B 6D</b>	<b>00111011 01101101</b>
<b>x &gt;&gt; 1</b>	<b>7606.5</b>	<b>7606</b>	<b>1D B6</b>	<b>00011101 10110110</b>
<b>x &gt;&gt; 4</b>	<b>950.8125</b>	<b>950</b>	<b>03 B6</b>	<b>00000011 10110110</b>
<b>x &gt;&gt; 8</b>	<b>59.4257813</b>	<b>59</b>	<b>00 3B</b>	<b>00000000 00111011</b>

# Signed Power-of-2 Divide with Shift

## ■ Quotient of Signed by Power of 2

- $x \gg k$  gives  $\lfloor x / 2^k \rfloor$
- Uses arithmetic shift
- Rounds wrong direction when  $u < 0$

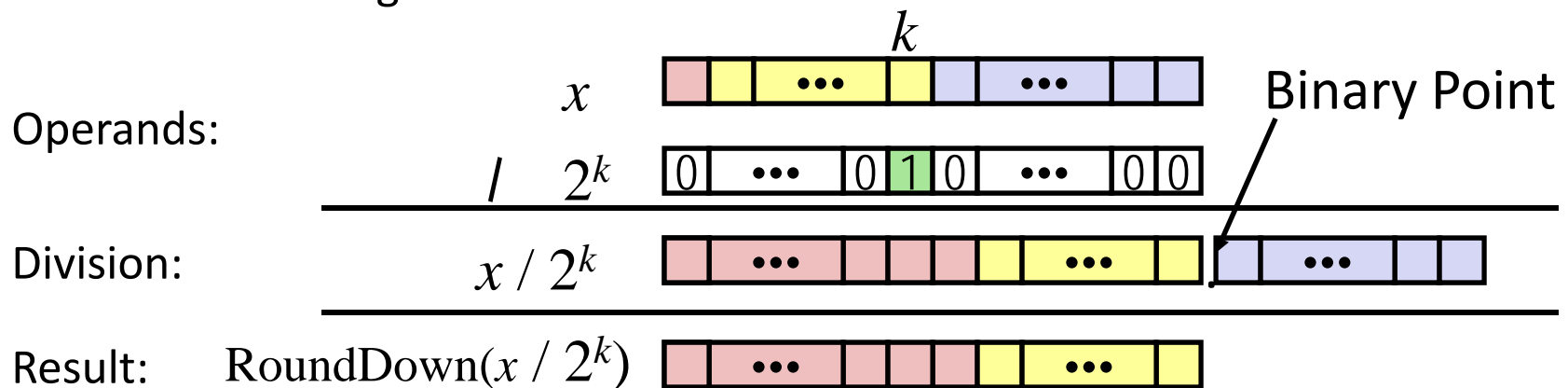

	Division	Computed	Hex	Binary
$y$	-15213	-15213	C4 93	11000100 10010011
$y \gg 1$	-7606.5	-7607	E2 49	11100010 01001001
$y \gg 4$	-950.8125	-951	FC 49	11111100 01001001
$y \gg 8$	-59.4257813	-60	FF C4	11111111 11000100

# Correct Power-of-2 Divide

## ■ Quotient of Negative Number by Power of 2

- Want  $\lceil x / 2^k \rceil$  (Round Toward 0)
- Compute as  $\lfloor (x+2^k-1) / 2^k \rfloor$ 
  - In C:  $(x + (1 \ll k) - 1) \gg k$
  - Biases dividend toward 0

### Case 1: No rounding

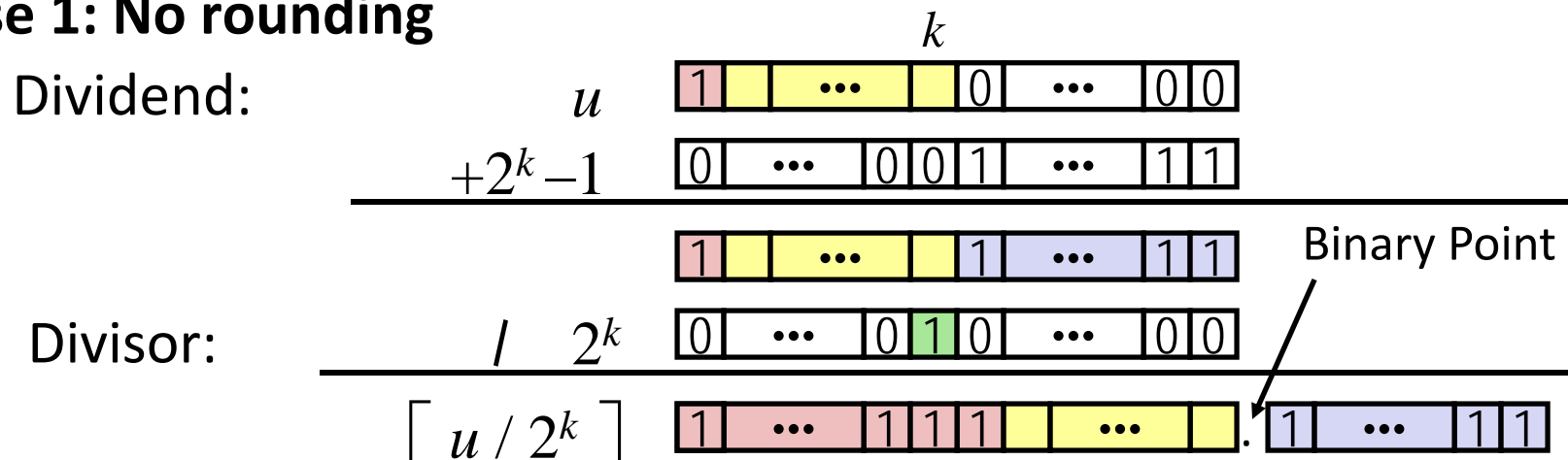

*Biassing has no effect*

# Correct Power-of-2 Divide (Cont.)

## Case 2: Rounding

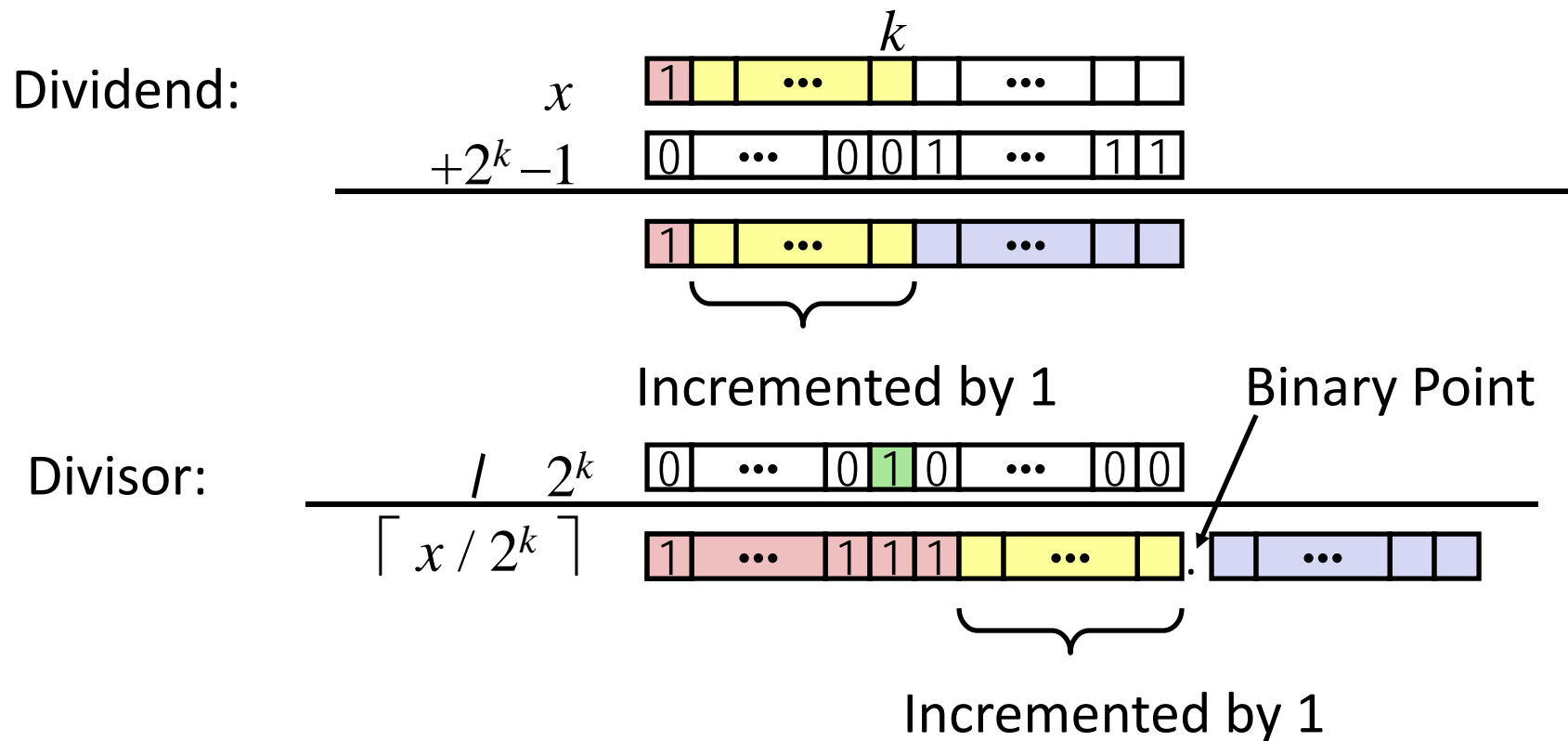

***Biasing adds 1 to final result***

# Today: Bits, Bytes, and Integers

- Representing information as bits
- Bit-level manipulations
- **Integers**
  - Representation: unsigned and signed
  - Conversion, casting
  - Expanding, truncating
  - Addition, negation, multiplication, shifting
  - **Summary**
- Representations in memory, pointers, strings



# Arithmetic: Basic Rules

## ■ Addition:

- Unsigned/signed: Normal addition followed by truncate, same operation on bit level
- Unsigned: addition mod  $2^w$ 
  - Mathematical addition + possible subtraction of  $2^w$
- Signed: modified addition mod  $2^w$  (result in proper range)
  - Mathematical addition + possible addition or subtraction of  $2^w$

## ■ Multiplication:

- Unsigned/signed: Normal multiplication followed by truncate, same operation on bit level
- Unsigned: multiplication mod  $2^w$
- Signed: modified multiplication mod  $2^w$  (result in proper range)

# Why Should I Use Unsigned?

## ■ *Don't Use Just Because Number Nonnegative*

- Easy to make mistakes

```
unsigned i;  
for (i = cnt-2; i >= 0; i--)  
    a[i] += a[i+1];
```

- Can be very subtle

```
#define DELTA sizeof(int)  
int i;  
for (i = CNT; i-DELTA >= 0; i-= DELTA)  
    . . .
```

## ■ *Do Use When Performing Modular Arithmetic*

- Multiprecision arithmetic

## ■ *Do Use When Using Bits to Represent Sets*

- Logical right shift, no sign extension

# Today: Bits, Bytes, and Integers

- Representing information as bits
- Bit-level manipulations
- Integers
  - Representation: unsigned and signed
  - Conversion, casting
  - Expanding, truncating
  - Addition, negation, multiplication, shifting
  - Summary
- **Representations in memory, pointers, strings**

# Byte-Oriented Memory Organization

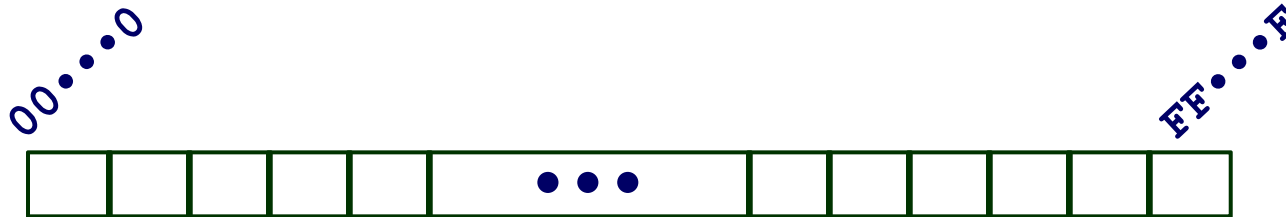

- **Programs refer to data by address**
  - Conceptually, envision it as a very large array of bytes
    - In reality, it's not, but can think of it that way
  - An address is like an index into that array
    - and, a pointer variable stores an address
- **Note: system provides private address spaces to each “process”**
  - Think of a process as a program being executed
  - So, a program can clobber its own data, but not that of others

# Machine Words

- **Any given computer has a “Word Size”**
  - Nominal size of integer-valued data
    - and of addresses
  - Most current machines use 32 bits (4 bytes) as word size
    - Limits addresses to 4GB ( $2^{32}$  bytes)
    - Becoming too small for memory-intensive applications
      - leading to emergence of computers with 64-bit word size
  - Machines still support multiple data formats
    - Fractions or multiples of word size
    - Always integral number of bytes

# Word-Oriented Memory Organization

## ■ Addresses Specify Byte Locations

- Address of first byte in word
- Addresses of successive words differ by 4 (32-bit) or 8 (64-bit)

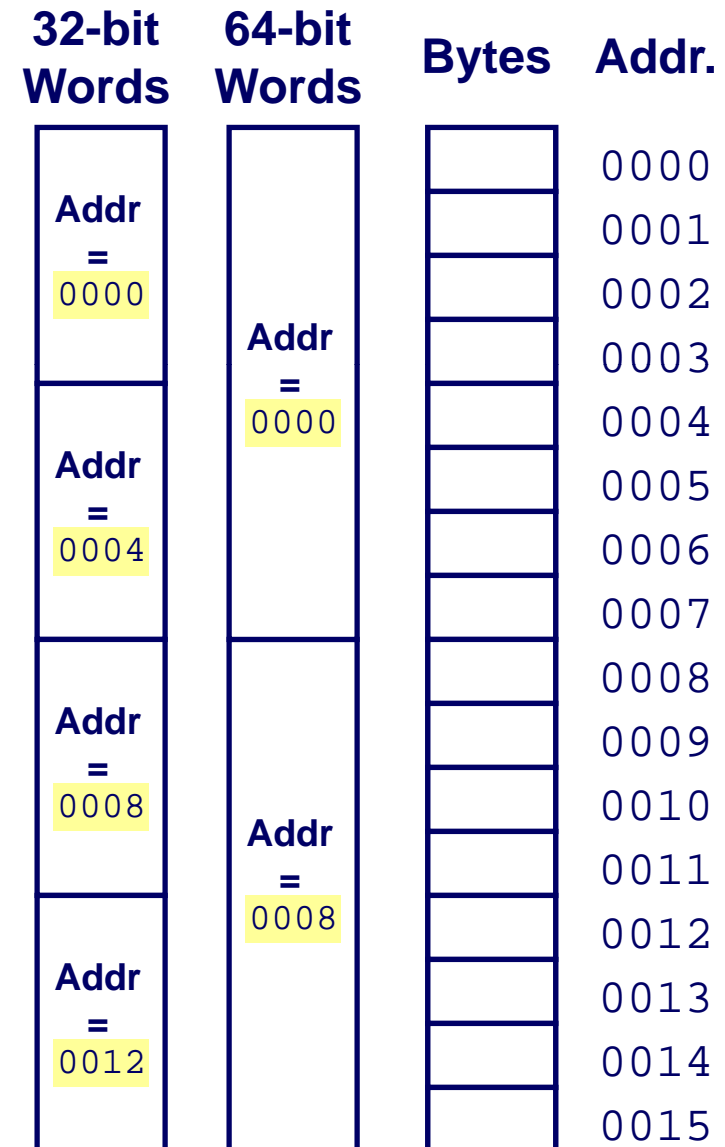

# For other data representations too ...

C Data Type	Typical 32-bit	Intel IA32	x86-64
char	1	1	1
short	2	2	2
int	4	4	4
long	4	4	8
long long	8	8	8
float	4	4	4
double	8	8	8
long double	8	10/12	10/16
pointer	4	4	8

# Byte Ordering

- **So, how are the bytes within a multi-byte word ordered in memory?**
- **Conventions**
  - Big Endian: Sun, PPC Mac, Internet
    - Least significant byte has highest address
  - Little Endian: x86
    - Least significant byte has lowest address



# Byte Ordering Example

## ■ Example

- Variable x has 4-byte value of 0x01234567
- Address given by &x is 0x100

### Big Endian

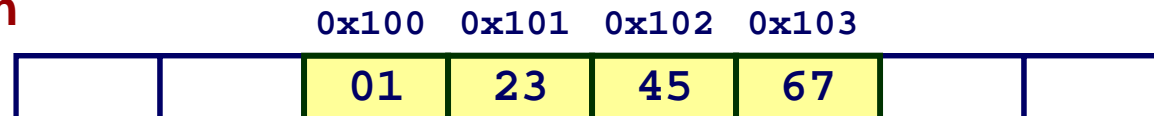

### Little Endian

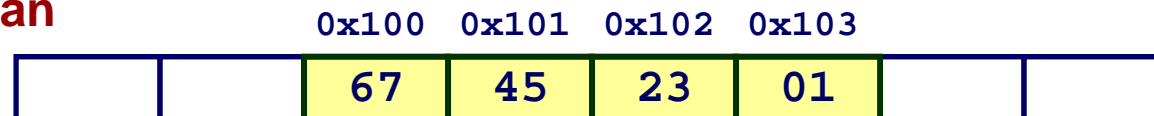

# Representing Integers

Decimal: 15213

Binary: 0011 1011 0110 1101

Hex: 3 B 6 D

int A = 15213;

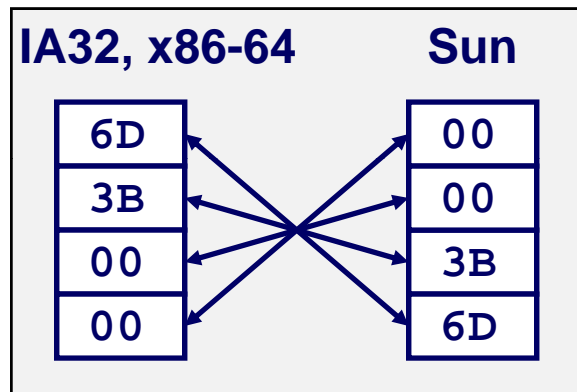

long int C = 15213;

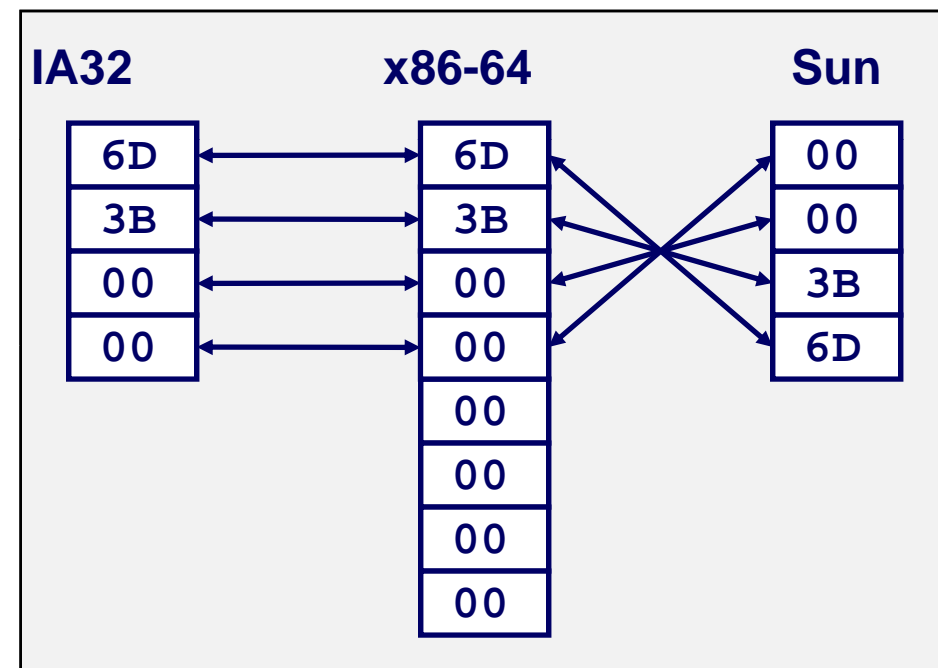

int B = -15213;

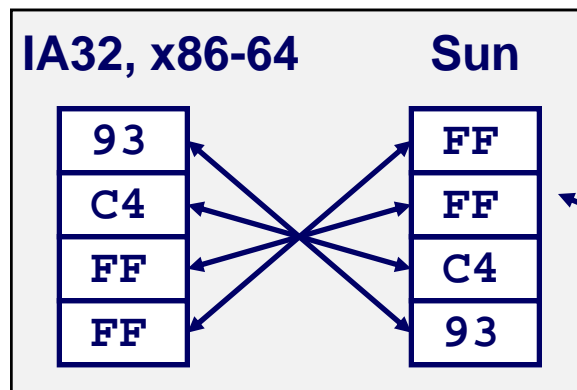

Two's complement representation

# Examining Data Representations

## ■ Code to Print Byte Representation of Data

- Casting pointer to unsigned char \* allows treatment as a byte array

```
typedef unsigned char *pointer;

void show_bytes(pointer start, int len){
    int i;
    for (i = 0; i < len; i++)
        printf("%p\t0x%.2x\n", start+i, start[i]);
    printf("\n");
}
```

### Printf directives:

%p: Print pointer

%x: Print Hexadecimal

# show\_bytes Execution Example

```
int a = 15213;
printf("int a = 15213;\n");
show_bytes((pointer) &a, sizeof(int));
```

## Result (Linux):

```
int a = 15213;
0x11ffffcb8 0x6d
0x11ffffcb9 0x3b
0x11ffffcba 0x00
0x11ffffcbb 0x00
```

# Representing Pointers

```
int B = -15213;  
int *P = &B;
```

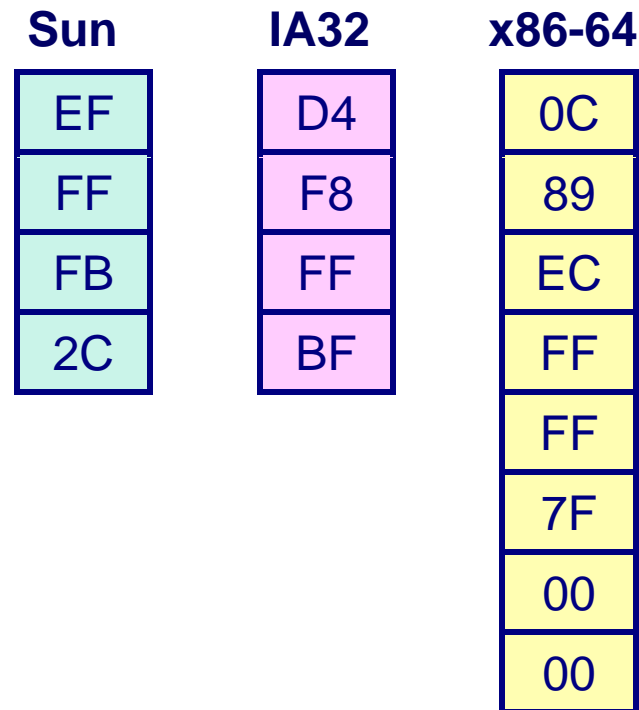

**Different compilers & machines assign different locations to objects**

# Representing Strings

```
char S[6] = "18243";
```

## ■ Strings in C

- Represented by array of characters
- Each character encoded in ASCII format
  - Standard 7-bit encoding of character set
  - Character "0" has code 0x30
    - Digit  $i$  has code  $0x30+i$
- String should be null-terminated
  - Final character = 0

## ■ Compatibility

- Byte ordering not an issue

Linux/Alpha

Sun

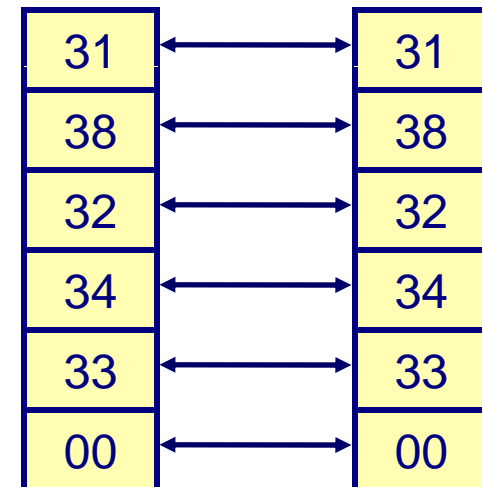

# Integer C Puzzles

## Initialization

```
int x = foo();
int y = bar();
unsigned ux = x;
unsigned uy = y;
```

- $x < 0 \Rightarrow ((x*2) < 0)$
- $ux \geq 0$
- $x \& 7 == 7 \Rightarrow (x \ll 30) < 0$
- $ux > -1$
- $x > y \Rightarrow -x < -y$
- $x * x \geq 0$
- $x > 0 \&\& y > 0 \Rightarrow x + y > 0$
- $x \geq 0 \Rightarrow -x \leq 0$
- $x \leq 0 \Rightarrow -x \geq 0$
- $(x|-x) \gg 31 == -1$
- $ux \gg 3 == ux/8$
- $x \gg 3 == x/8$
- $x \& (x-1) != 0$