

Parallel Architecture Fundamentals

**Todd C. Mowry
CS 740**

November 3, 1998

Topics

- **What is Parallel Architecture?**
- **Why Parallel Architecture?**
- **Evolution and Convergence of Parallel Architectures**
- **Fundamental Design Issues**

What is Parallel Architecture?

A parallel computer is a collection of processing elements that cooperate to solve large problems fast

Some broad issues:

- **Resource Allocation:**
 - how large a collection?
 - how powerful are the elements?
 - how much memory?
- **Data access, Communication and Synchronization**
 - how do the elements cooperate and communicate?
 - how are data transmitted between processors?
 - what are the abstractions and primitives for cooperation?
- **Performance and Scalability**
 - how does it all translate into performance?
 - how does it scale?

Why Study Parallel Architecture?

Role of a computer architect:

- To design and engineer the various levels of a computer system to maximize *performance* and *programmability* within limits of *technology* and *cost*.

Parallelism:

- Provides alternative to faster clock for performance
- Applies at all levels of system design
- Is a fascinating perspective from which to view architecture
- Is increasingly central in information processing

Why Study it Today?

History: diverse and innovative organizational structures, often tied to novel programming models

Rapidly maturing under strong technological constraints

- The “killer micro” is ubiquitous
- Laptops and supercomputers are fundamentally similar!
- Technological trends cause diverse approaches to converge

Technological trends make parallel computing inevitable

- In the mainstream

Need to understand fundamental principles and design tradeoffs, not just taxonomies

- Naming, Ordering, Replication, Communication performance

Inevitability of Parallel Computing

Application demands: Our insatiable need for cycles

- *Scientific computing*: CFD, Biology, Chemistry, Physics, ...
- *General-purpose computing*: Video, Graphics, CAD, Databases, TP...

Technology Trends

- Number of transistors on chip growing rapidly
- Clock rates expected to go up only slowly

Architecture Trends

- Instruction-level parallelism valuable but limited
- Coarser-level parallelism, as in MPs, the most viable approach

Economics

Current trends:

- Today's microprocessors have multiprocessor support
- Servers, workstations, & PCs becoming MP: Sun, SGI, COMPAQ, Dell,...
- *Tomorrow's microprocessors are multiprocessors*

Application Trends

Demand for cycles fuels advances in hardware, and vice-versa

- Cycle drives exponential increase in microprocessor performance
- Drives parallel architecture harder: most demanding applications

Range of performance demands

- Need range of system performance with progressively increasing cost
- Platform pyramid

Goal of applications in using parallel machines: Speedup

$$\text{Speedup } (p \text{ processors}) = \frac{\text{Performance } (p \text{ processors})}{\text{Performance } (1 \text{ processor})}$$

For a fixed problem size (input data set), performance = 1/time

$$\text{Speedup } \textit{fixed problem} (p \text{ processors}) = \frac{\text{Time } (1 \text{ processor})}{\text{Time } (p \text{ processors})}$$

Scientific Computing Demand

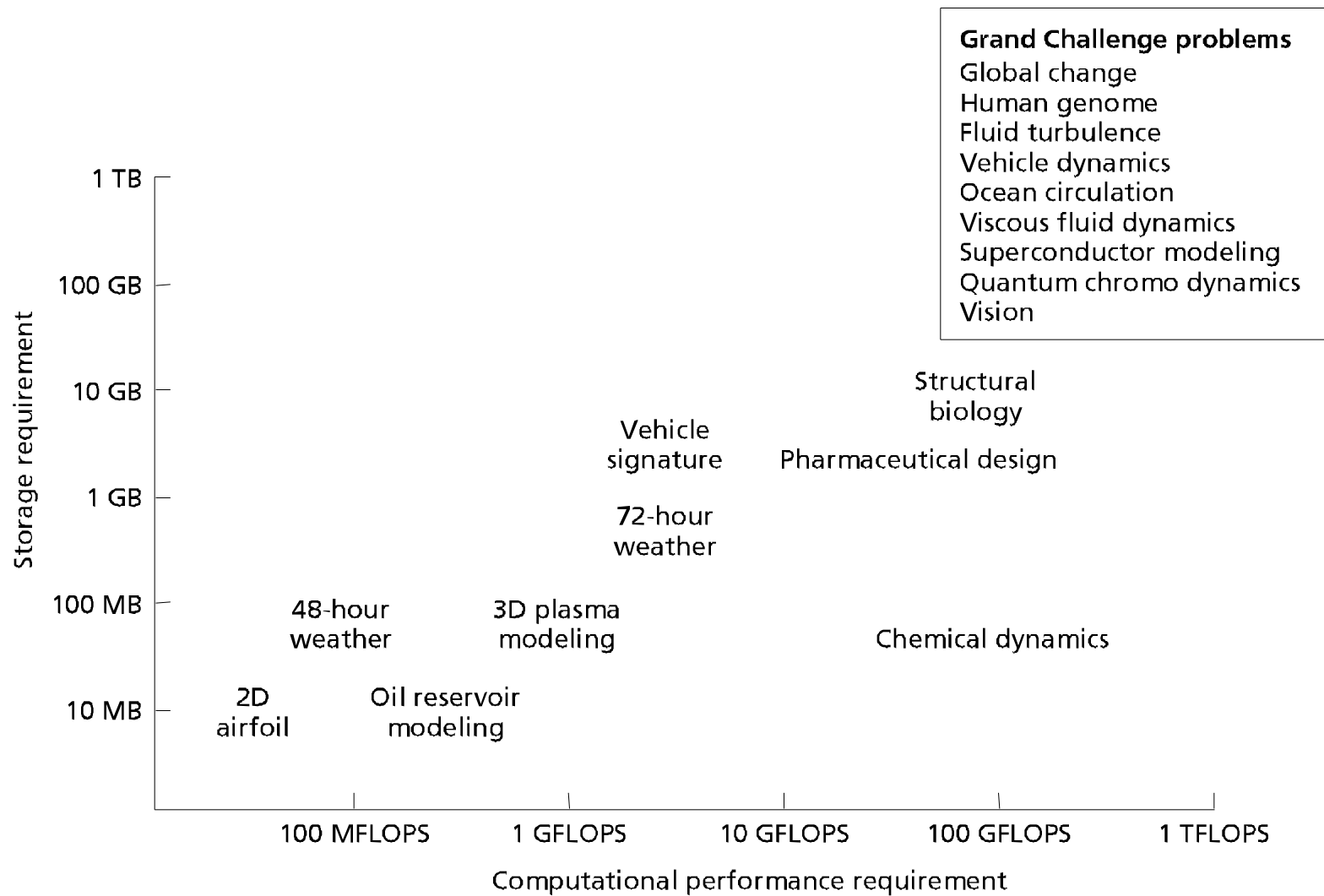

Engineering Computing Demand

Large parallel machines a mainstay in many industries

- **Petroleum** (reservoir analysis)
- **Automotive** (crash simulation, drag analysis, combustion efficiency),
- **Aeronautics** (airflow analysis, engine efficiency, structural mechanics, electromagnetism),
- **Computer-aided design**
- **Pharmaceuticals** (molecular modeling)
- **Visualization**
 - in all of the above
 - entertainment (films like Toy Story)
 - architecture (walk-throughs and rendering)
- **Financial modeling** (yield and derivative analysis)
- **etc.**

Learning Curve for Parallel Programs

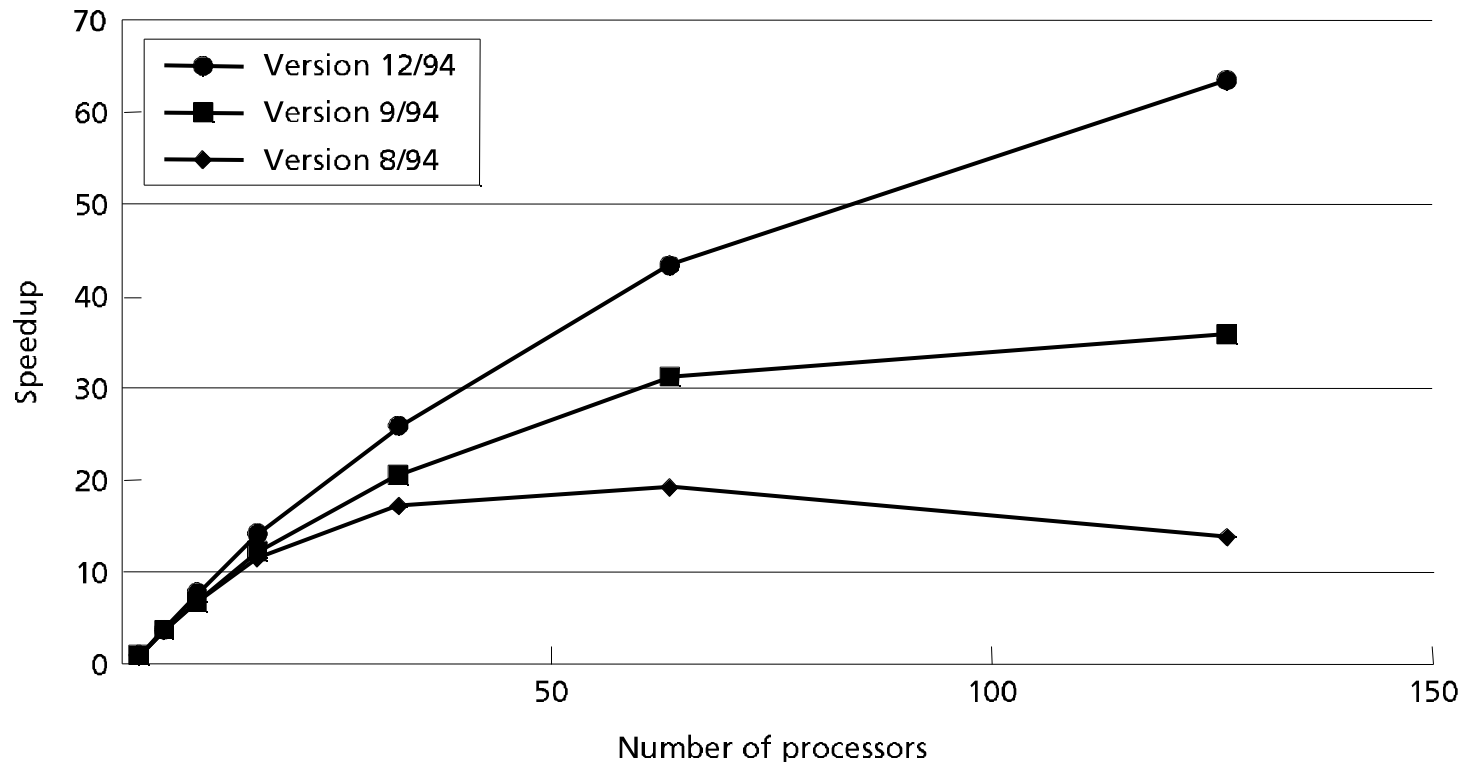

- AMBER molecular dynamics simulation program
- Starting point was vector code for Cray-1
- 145 MFLOP on Cray90, 406 for final version on 128-processor Paragon, 891 on 128-processor Cray T3D

Commercial Computing

Also relies on parallelism for high end

- Scale not so large, but use much more wide-spread
- Computational power determines scale of business that can be handled

Databases, online-transaction processing, decision support, data mining, data warehousing ...

TPC benchmarks (**TPC-C** order entry, **TPC-D** decision support)

- Explicit scaling criteria provided
- Size of enterprise scales with size of system
- Problem size no longer fixed as p increases, so **throughput** is used as a performance measure (transactions per minute or **tpm**)

TPC-C Results for March 1996

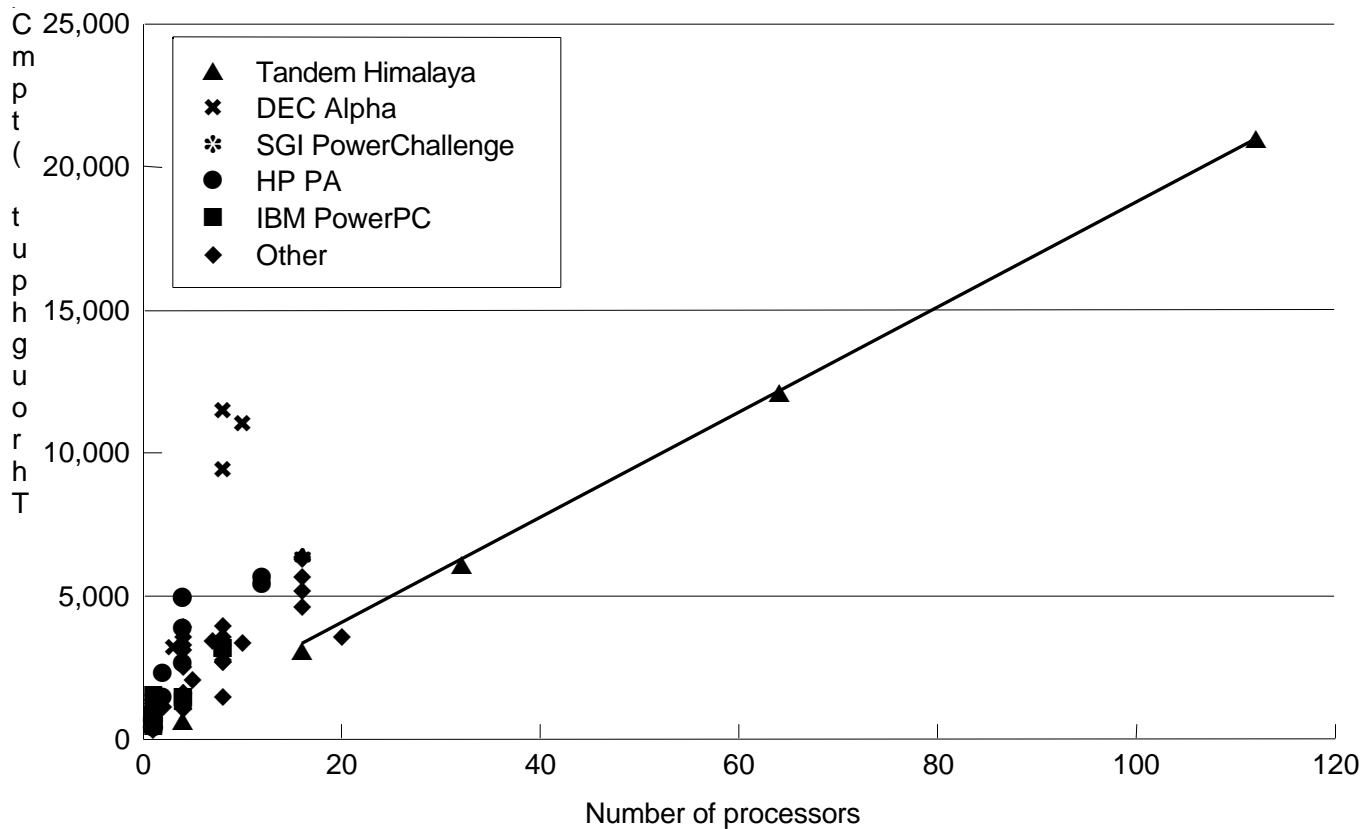

Summary of Application Trends

Transition to parallel computing has occurred for **scientific and engineering computing**

In rapid progress in **commercial computing**

- Database and transactions as well as financial
- Usually smaller-scale, but large-scale systems also used

Desktop also uses **multithreaded** programs, which are a lot like parallel programs

Demand for improving **throughput** on sequential workloads

- Greatest use of small-scale multiprocessors

Solid application demand exists and will increase

Technology Trends

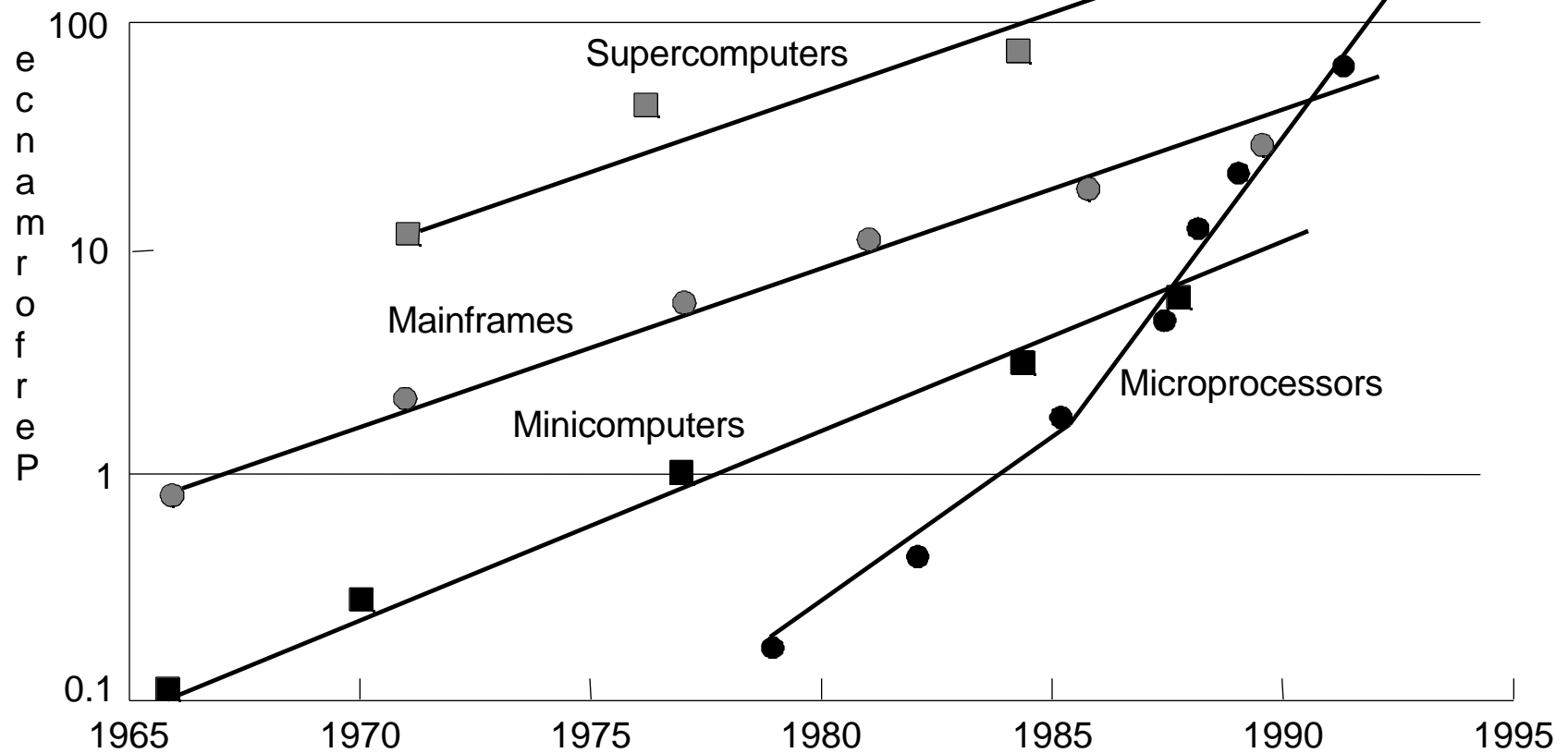

Commodity microprocessors have caught up with supercomputers.

Architectural Trends

Architecture translates **technology's gifts** to **performance** and **capability**

Resolves the tradeoff between parallelism and locality

- Current microprocessor: 1/3 compute, 1/3 cache, 1/3 off-chip connect
- Tradeoffs may change with scale and technology advances

Understanding microprocessor architectural trends

- Helps build intuition about design issues or parallel machines
- Shows fundamental role of parallelism even in “sequential” computers

Four generations of architectural history: tube, transistor, IC, VLSI

- Here focus only on **VLSI** generation

Greatest delineation in VLSI has been in type of parallelism exploited

Arch. Trends: Exploiting Parallelism

Greatest trend in VLSI generation is increase in parallelism

- **Up to 1985: bit level parallelism: 4-bit -> 8 bit -> 16-bit**
 - slows after 32 bit
 - adoption of 64-bit now under way, 128-bit far (not performance issue)
 - great inflection point when 32-bit micro and cache fit on a chip
- **Mid 80s to mid 90s: instruction level parallelism**
 - pipelining and simple instruction sets, + compiler advances (RISC)
 - on-chip caches and functional units => superscalar execution
 - greater sophistication: out of order execution, speculation, prediction
 - » to deal with control transfer and latency problems
- **Next step: thread level parallelism**

Phases in VLSI Generation

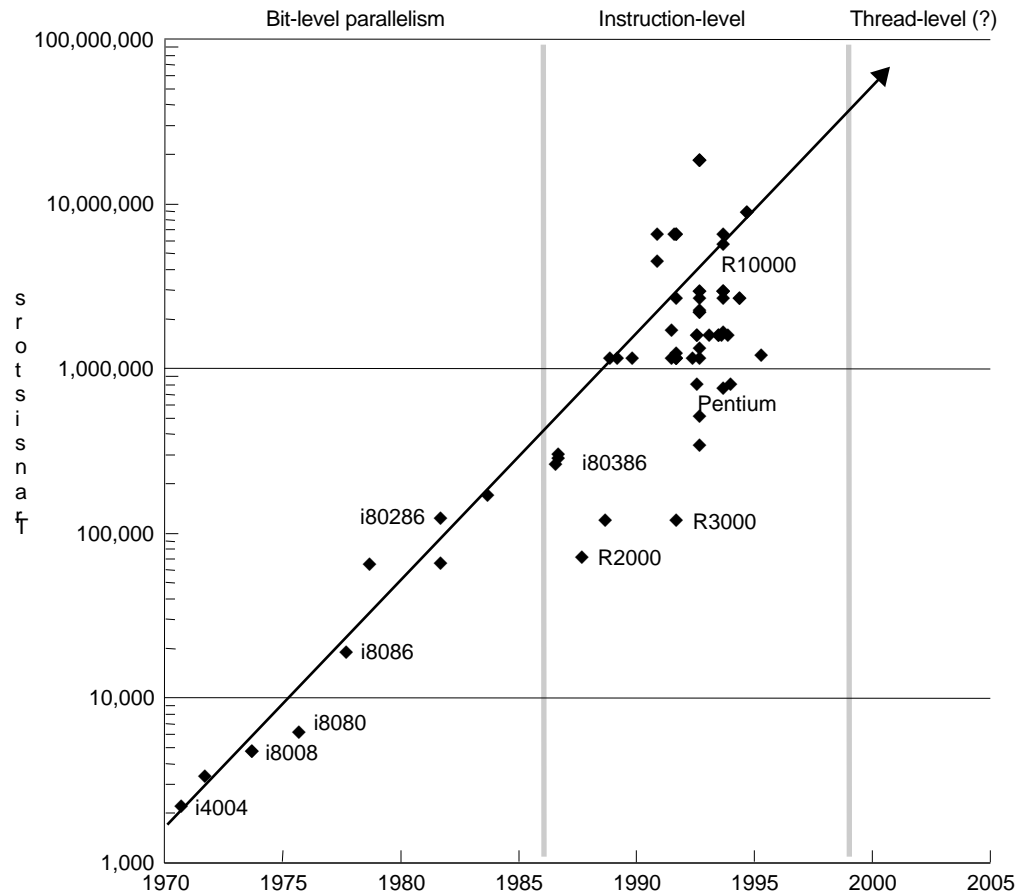

- How good is instruction-level parallelism?
- Thread-level needed in microprocessors?

Architectural Trends: ILP

- **Reported speedups for superscalar processors**

• Horst, Harris, and Jardine [1990]	1.37
• Wang and Wu [1988]	1.70
• Smith, Johnson, and Horowitz [1989]	2.30
• Murakami et al. [1989]	2.55
• Chang et al. [1991]	2.90
• Jouppi and Wall [1989]	3.20
• Lee, Kwok, and Briggs [1991]	3.50
• Wall [1991]	5
• Melvin and Patt [1991]	8
• Butler et al. [1991]	17+

- **Large variance due to difference in**

- application domain investigated (numerical versus non-numerical)
- capabilities of processor modeled

ILP Ideal Potential

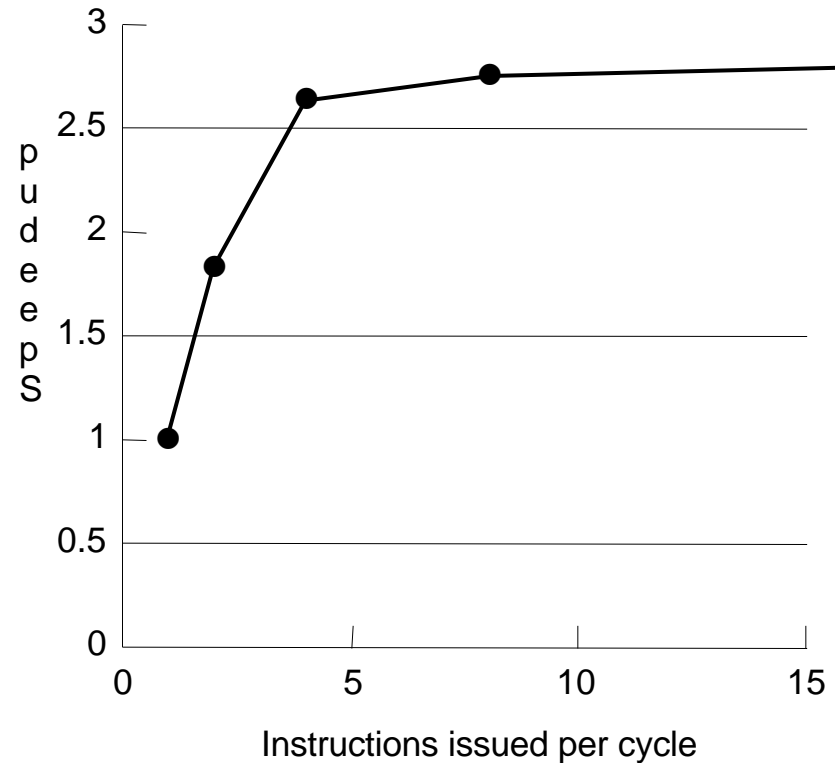
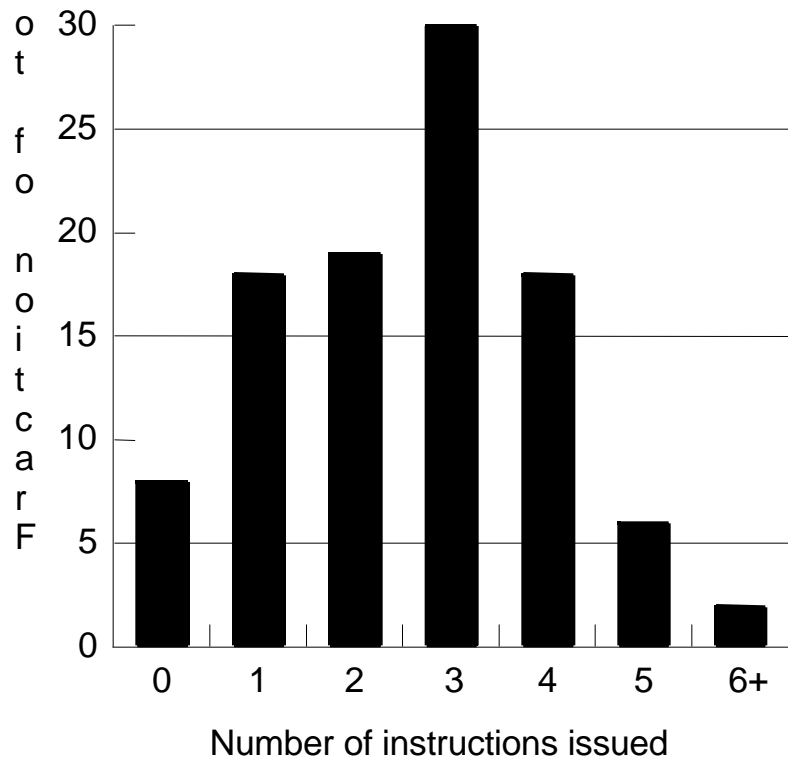

- **Infinite resources and fetch bandwidth, perfect branch prediction and renaming**
 - real caches and non-zero miss latencies

Results of ILP Studies

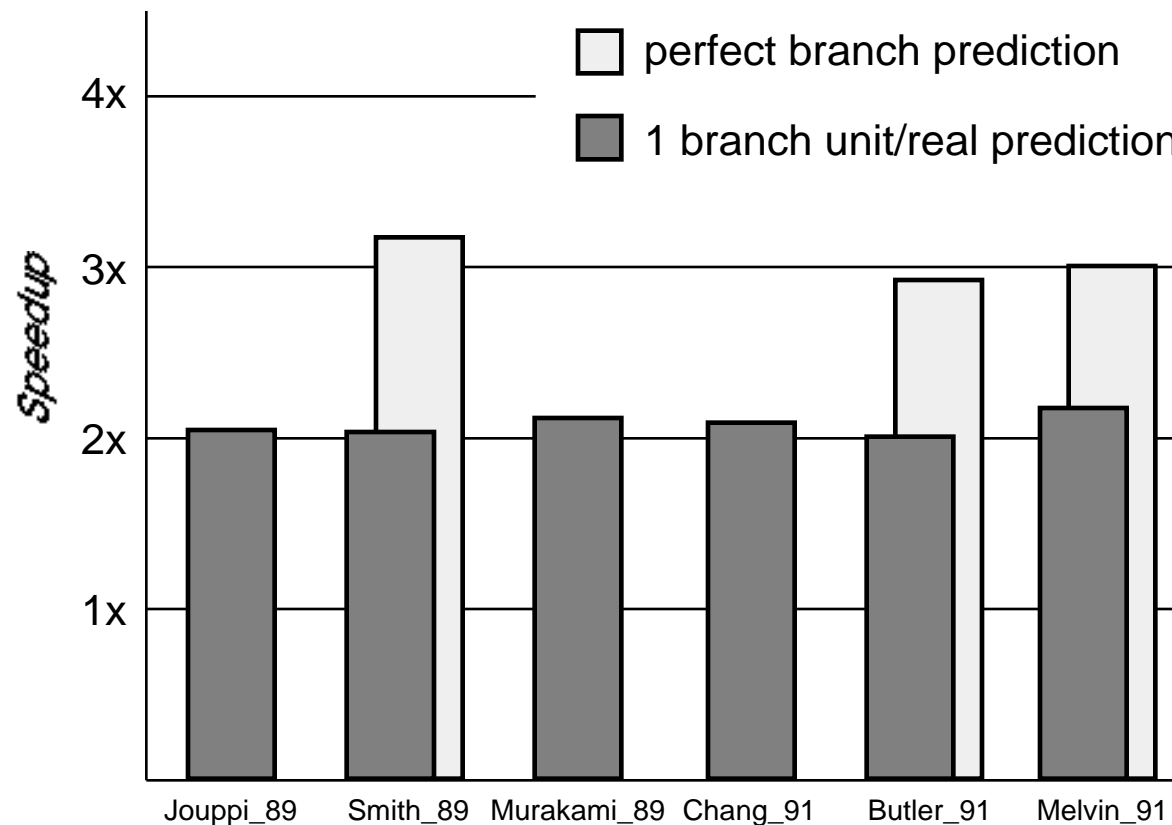

- Concentrate on parallelism for 4-issue machines
- Realistic studies show only **2-fold speedup**
- Recent studies show that for more parallelism, one must look **across threads**

Economics

Commodity microprocessors not only **fast** but **CHEAP**

- Development cost is tens of millions of dollars (5-100 typical)
- BUT, many more are sold compared to supercomputers
- Crucial to take advantage of the investment, and use the commodity building block
- Exotic parallel architectures no more than special-purpose

Multiprocessors being pushed by software vendors (e.g. database) as well as hardware vendors

Standardization by Intel makes small, bus-based SMPs commodity

Desktop: few smaller processors versus one larger one?

- Multiprocessor on a chip

Summary: Why Parallel Architecture?

Increasingly attractive

- Economics, technology, architecture, application demand

Increasingly central and mainstream

Parallelism exploited at many levels

- Instruction-level parallelism
- Thread-level parallelism within a microprocessor
- Multiprocessor servers
- Large-scale multiprocessors (“MPPs”)

Same story from memory system perspective

- Increase bandwidth, reduce average latency with many local memories

Wide range of parallel architectures make sense

- Different cost, performance and scalability

Convergence of Parallel Architectures

History

Historically, parallel architectures tied to programming models

- Divergent architectures, with no predictable pattern of growth.

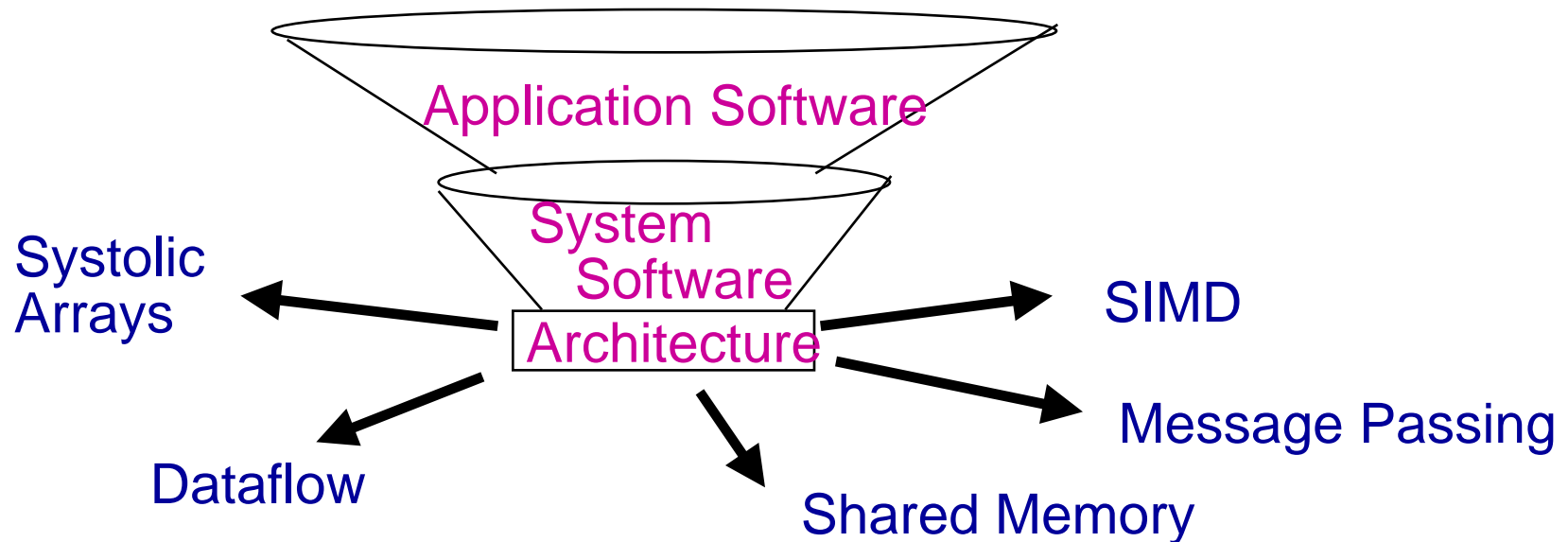

Uncertainty of direction paralyzed parallel software development!

Today

Extension of “computer architecture” to support communication and cooperation

- OLD: **Instruction Set Architecture**
- NEW: *Communication Architecture*

Defines

- Critical abstractions, boundaries, and primitives (interfaces)
- Organizational structures that implement interfaces (hw or sw)

Compilers, libraries and OS are important bridges today

Modern Layered Framework

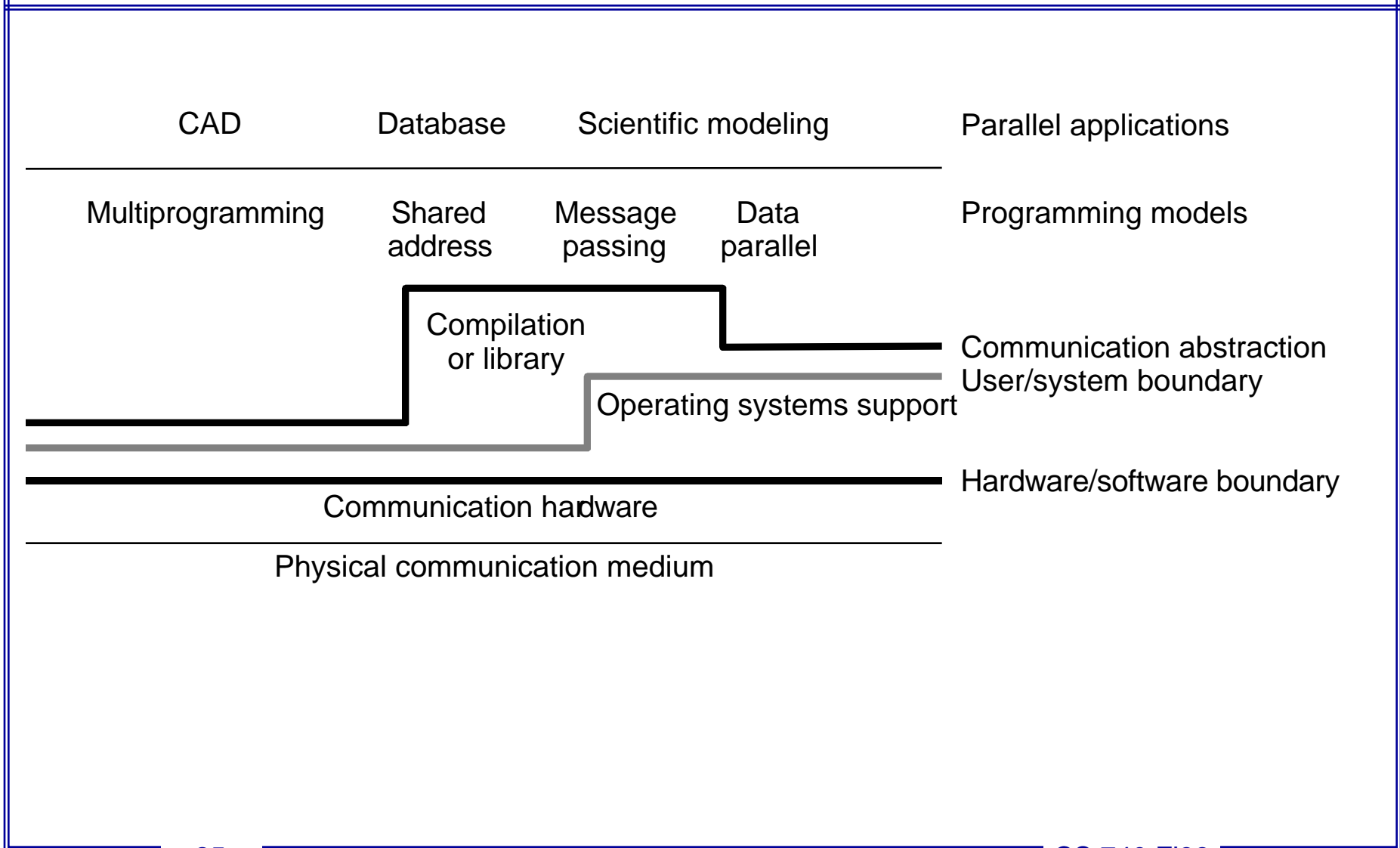

Programming Model

What programmer uses in coding applications
Specifies communication and synchronization

Examples:

- **Multiprogramming**: no communication or synch. at program level
- **Shared address space**: like bulletin board
- **Message passing**: like letters or phone calls, explicit point to point
- **Data parallel**: more regimented, global actions on data
 - Implemented with shared address space or message passing

Communication Abstraction

User level communication primitives provided

- Realizes the programming model
- Mapping exists between language primitives of programming model and these primitives

Supported directly by **hw**, or via **OS**, or via **user sw**

Lot of debate about what to support in sw and gap between layers

Today:

- Hw/sw interface tends to be flat, i.e. complexity roughly uniform
- Compilers and software play important roles as bridges today
- Technology trends exert strong influence

Result is convergence in organizational structure

- Relatively simple, general purpose communication primitives

Communication Architecture

= *User/System Interface* + *Implementation*

User/System Interface:

- Comm. primitives exposed to user-level by hw and system-level sw

Implementation:

- Organizational structures that implement the primitives: hw or OS
- How optimized are they? How integrated into processing node?
- Structure of network

Goals:

- Performance
- Broad applicability
- Programmability
- Scalability
- Low Cost

Evolution of Architectural Models

Historically, machines tailored to programming models

- Programming model, communication abstraction, and machine organization lumped together as the “architecture”

Evolution helps understand convergence

- Identify core concepts

Most Common Models:

- Shared Address Space, Message Passing, Data Parallel

Other Models:

- Dataflow, Systolic Arrays

Examine programming model, motivation, intended applications, and contributions to convergence

Shared Address Space Architectures

Any processor can **directly** reference any memory location

- Communication occurs implicitly as result of loads and stores

Convenient:

- Location transparency
- Similar programming model to time-sharing on uniprocessors
 - Except processes run on different processors
 - Good throughput on multiprogrammed workloads

Naturally provided on wide range of platforms

- History dates at least to precursors of mainframes in early 60s
- Wide range of scale: few to hundreds of processors

Popularly known as **shared memory** machines or model

- Ambiguous: memory may be **physically distributed** among processors

Shared Address Space Model

Process: virtual address space plus one or more threads of control

Portions of address spaces of processes are shared

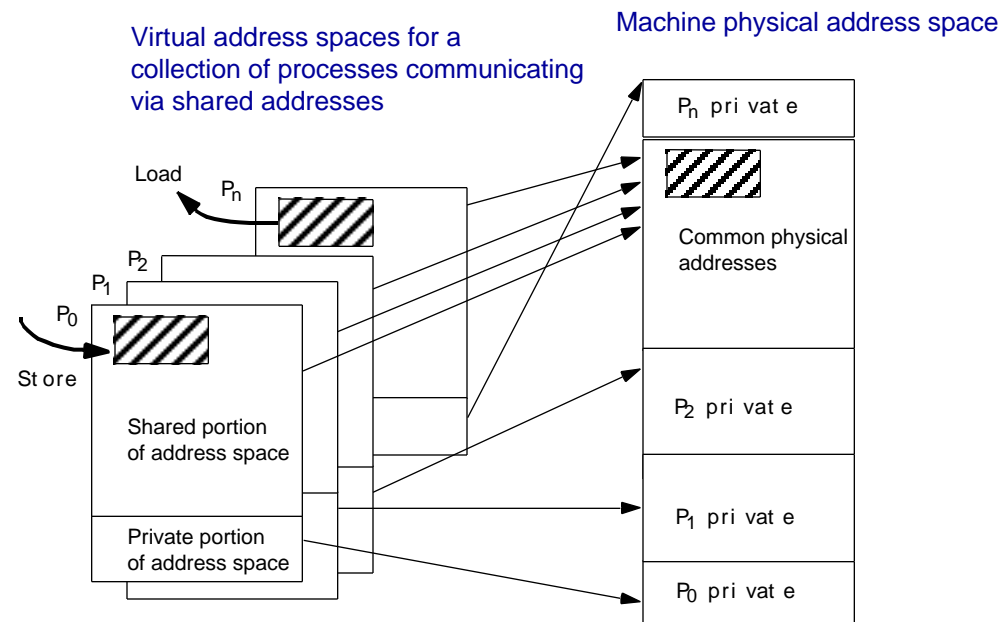

- Writes to shared address visible to other threads (in other processes too)
- Natural extension of uniprocessor model:** conventional memory operations for comm.; special atomic operations for synchronization
- OS uses shared memory to coordinate processes

Communication Hardware

Also a natural extension of a uniprocessor

Already have processor, one or more memory modules and I/O controllers connected by hardware interconnect of some sort

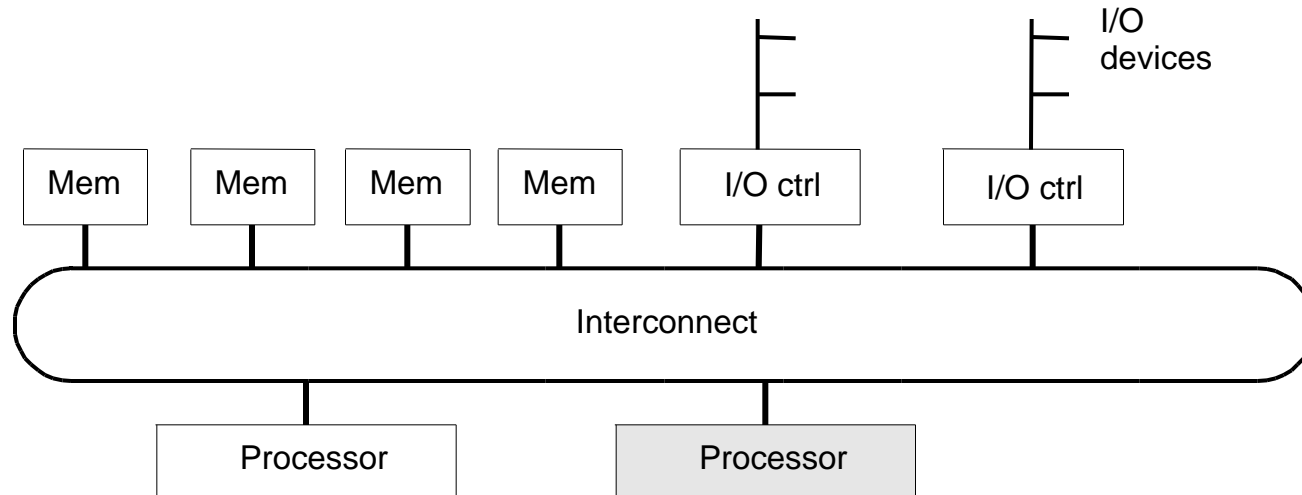

Memory capacity increased by adding modules, I/O by controllers

- Add processors for processing!
- For higher-throughput multiprocessing, or parallel programs

History

“Mainframe” approach:

- Motivated by multiprogramming
- Extends crossbar used for mem bw and I/O
- Originally processor cost limited to small scale
 - later, cost of crossbar
- Bandwidth scales with p
- **High incremental cost**; use multistage instead

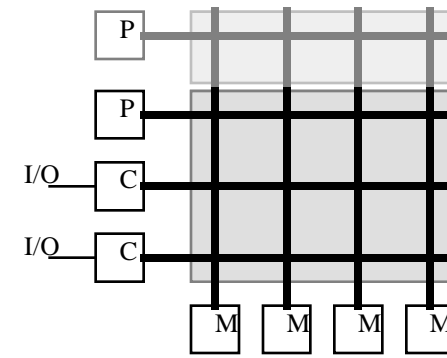

“Minicomputer” approach:

- Almost all microprocessor systems have bus
- Motivated by multiprogramming, TP
- Used heavily for parallel computing
- Called symmetric multiprocessor (SMP)
- Latency larger than for uniprocessor
- Bus is bandwidth bottleneck
 - caching is key: **coherence problem**
- Low incremental cost

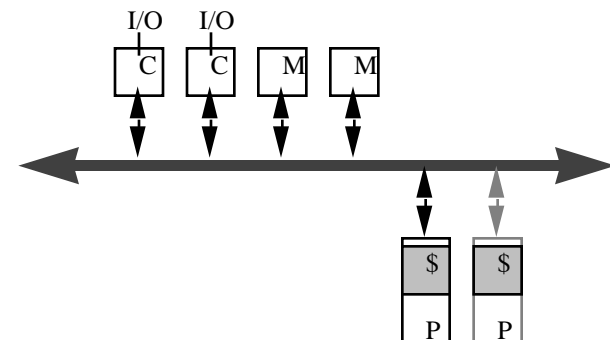

Example: Intel Pentium Pro Quad

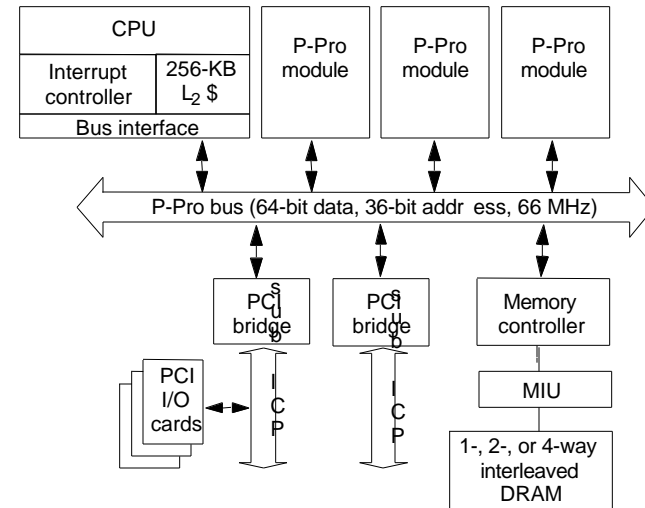
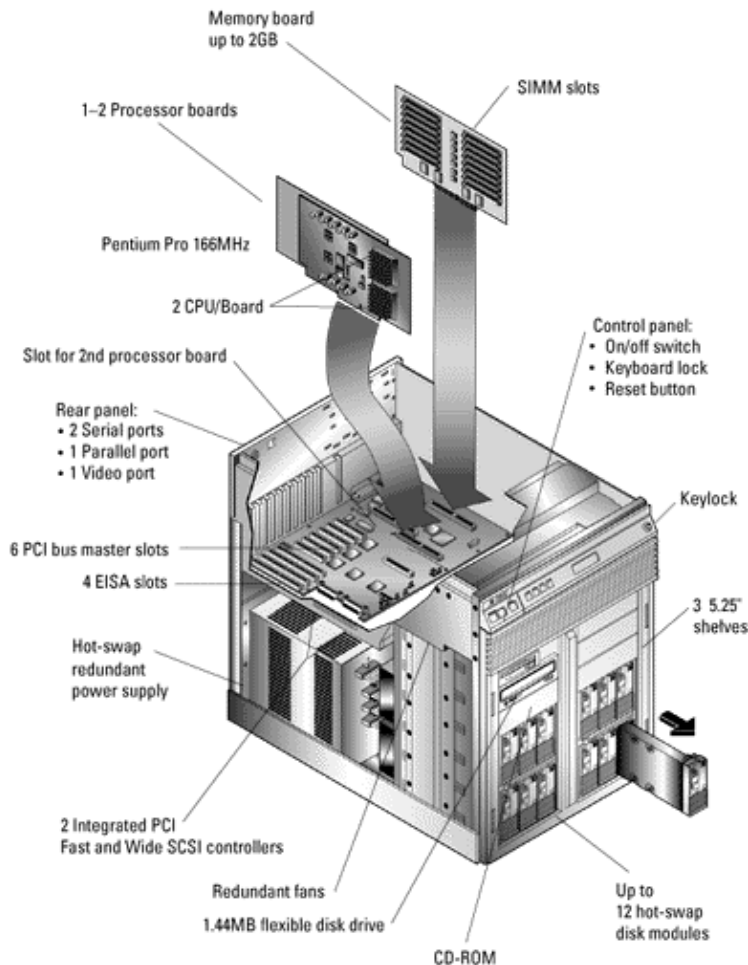

- All coherence and multiprocessing glue in processor module
- Highly integrated, targeted at high volume
- Low latency and bandwidth

Example: SUN Enterprise

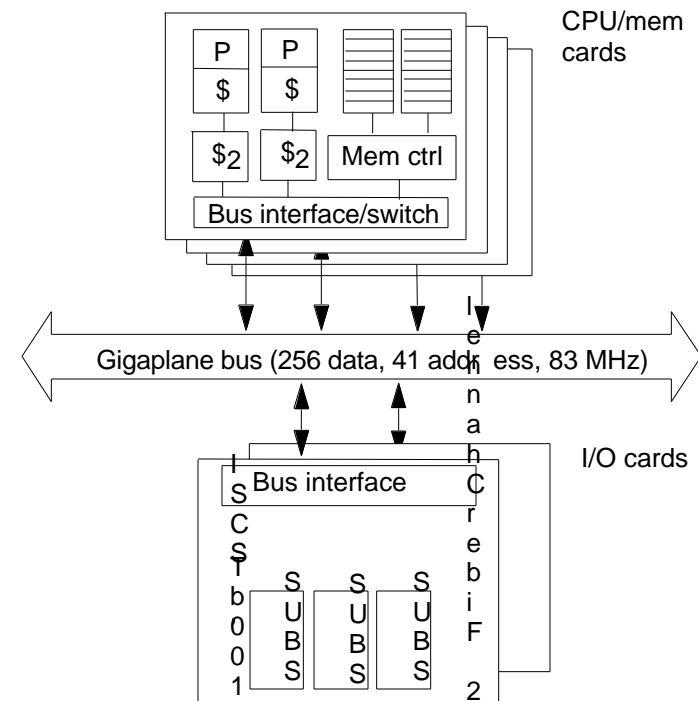

- **16** cards of either type: processors + memory, or I/O
- All memory accessed over bus, so symmetric
- **Higher bandwidth, higher latency bus**

Scaling Up

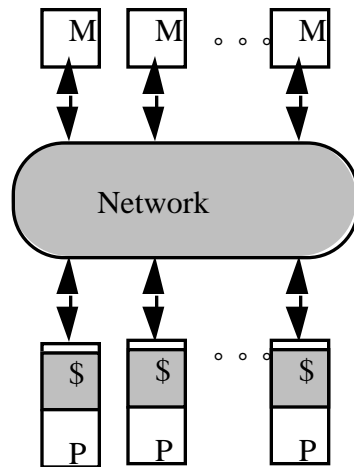

“Dance hall”

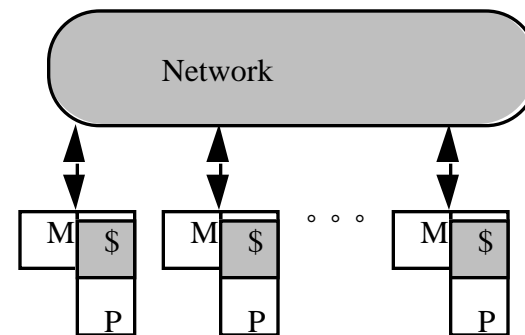

Distributed memory

- **Problem is interconnect: cost (crossbar) or bandwidth (bus)**
- **Dance-hall:** bandwidth still scalable, but lower cost than crossbar
 - latencies to memory uniform, but **uniformly large**
- **Distributed memory or non-uniform memory access (NUMA)**
 - Construct shared address space out of simple message transactions across a general-purpose network (e.g. read-request, read-response)
- **Caching shared (particularly nonlocal) data?**

Example: Cray T3E

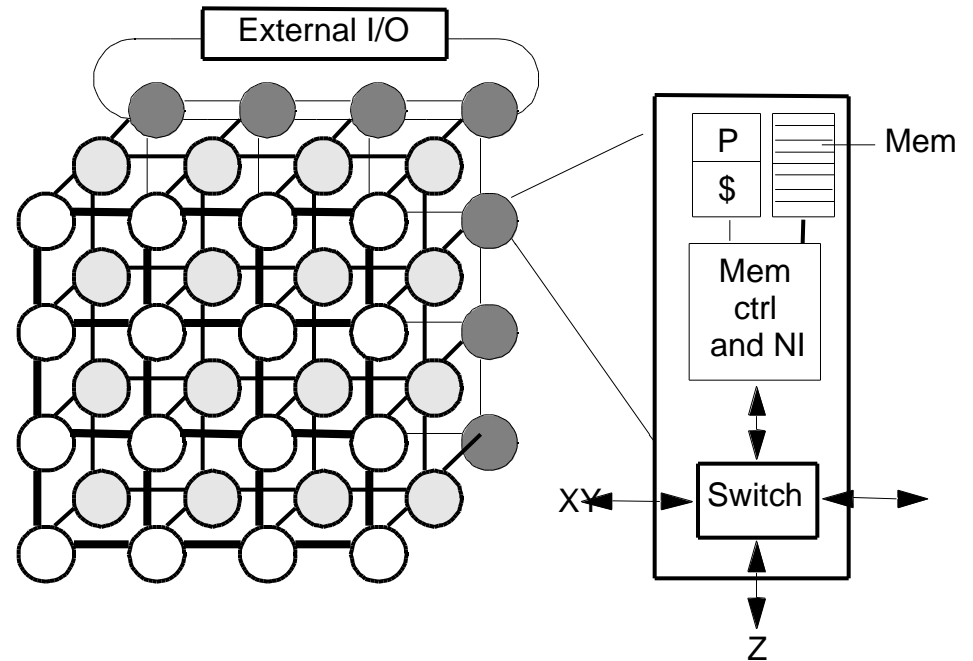

- Scale up to **1024 processors**, **480MB/s** links
- Memory controller generates comm. request for nonlocal references
- **No hardware mechanism for coherence** (SGI Origin etc. provide this)

Message Passing Architectures

Complete computer as building block, including I/O

- Communication via explicit I/O operations

Programming model:

- directly access only **private address space** (local memory)
- communicate via explicit messages (**send/receive**)

High-level block diagram similar to distributed-mem. SAS

- But comm. integrated at IO level, need not put into memory system
- Like networks of workstations (clusters), but tighter integration
- Easier to build than scalable SAS

Programming model further from basic hardware ops

- Library or OS intervention

Message Passing Abstraction

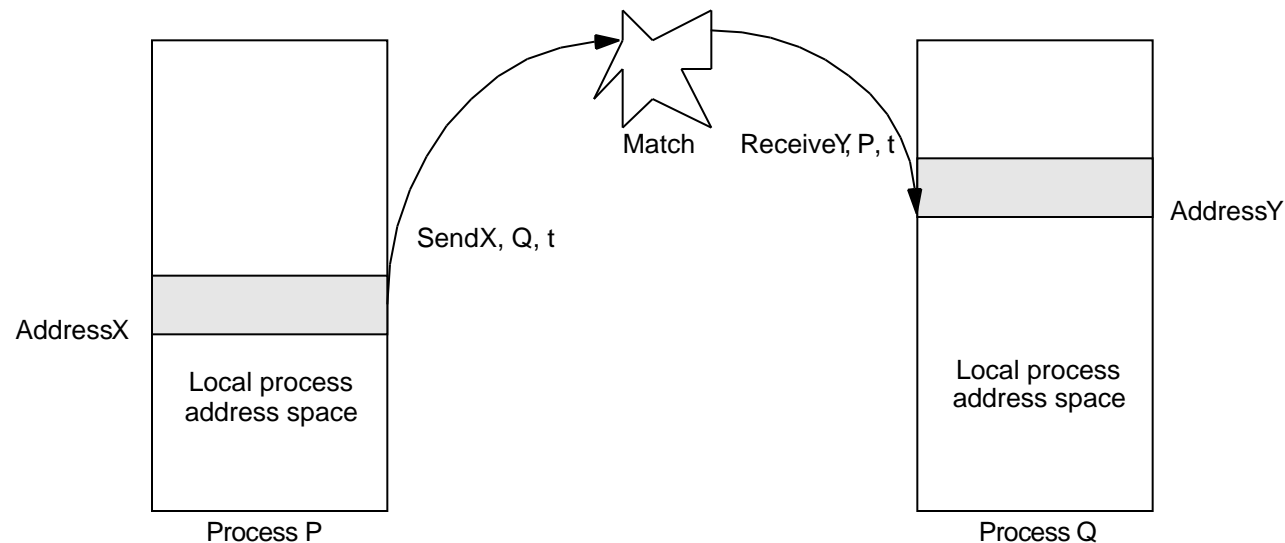

- **Send** specifies buffer to be transmitted and receiving process
- **Recv** specifies sending process and application storage to receive into
- **Memory to memory copy**, but need to name processes
- Optional tag on send and matching rule on receive
- User process names local data and entities in process/tag space too
- In simplest form, the send/recv match achieves pairwise synchrony event
 - Other variants too
- **Many overheads: copying, buffer management, protection**

Evolution of Message Passing

Early machines: FIFO on each link

- **Hardware close to programming model**
 - synchronous ops
- **Replaced by DMA, enabling non-blocking ops**
 - Buffered by system at destination until recv

Diminishing role of topology

- **Store & forward routing: topology important**
- **Introduction of pipelined routing made it less so**
- **Cost is in node-network interface**
- **Simplifies programming**

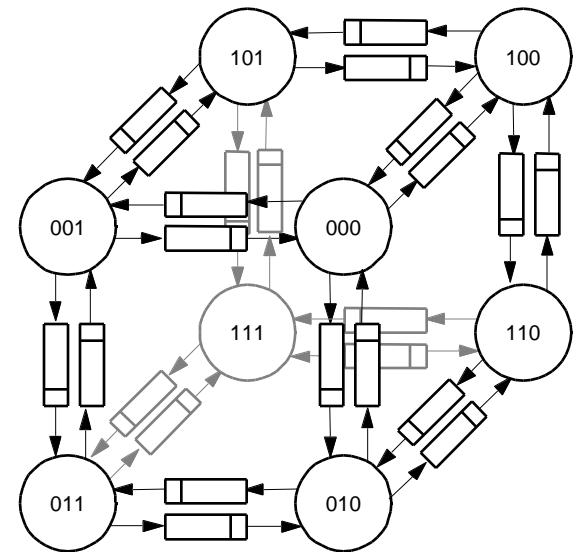

Example: IBM SP-2



General interconnection network formed from 8-port switches

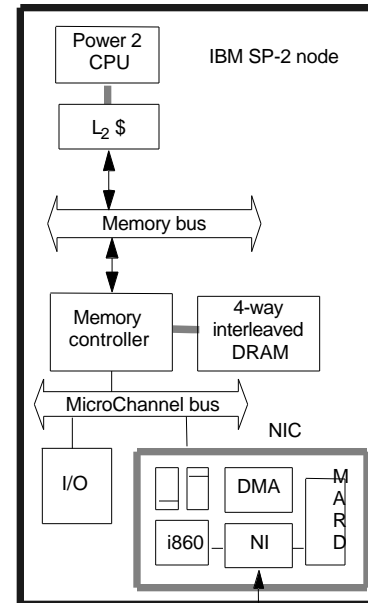
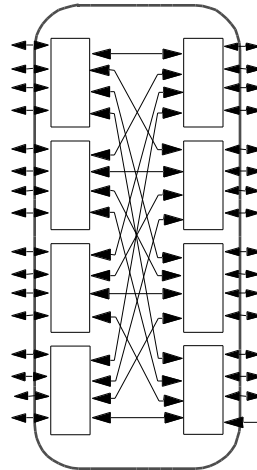

- Made out of essentially complete RS6000 workstations
- Network interface integrated in I/O bus (bw limited by I/O bus)

Example: Intel Paragon

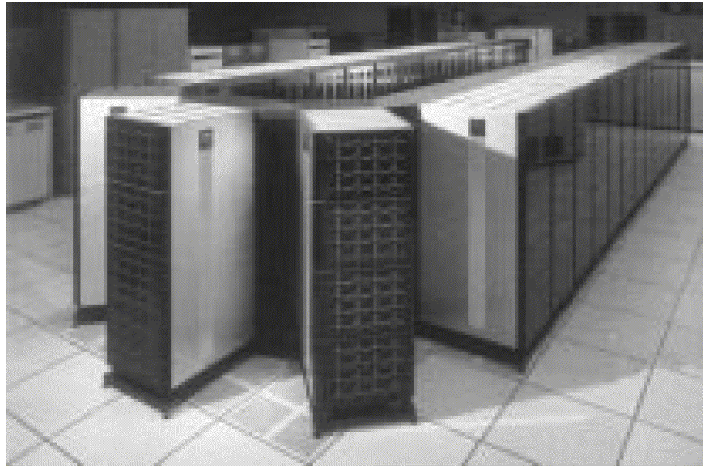

Sandia's Intel Paragon XP/S-based Supercomputer

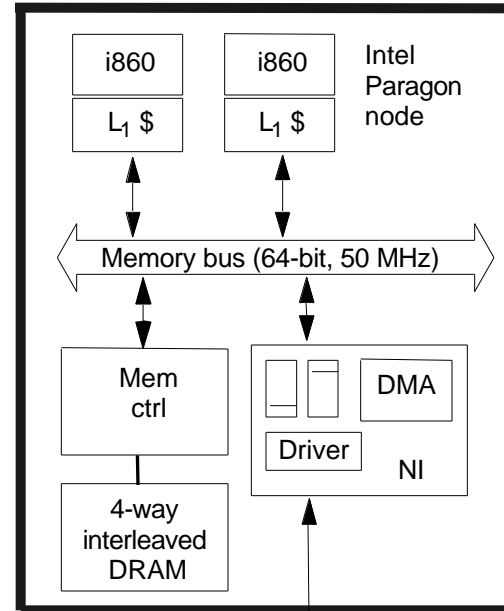

2D grid network
with processing node
attached to every switch

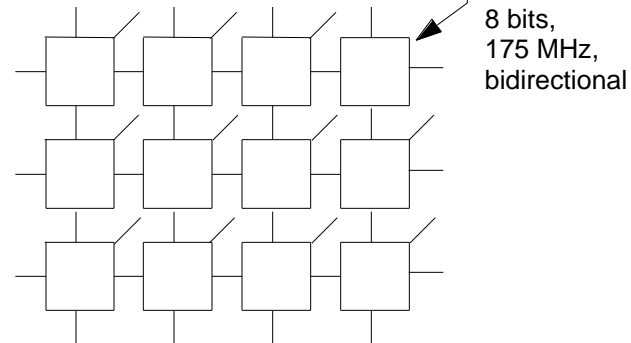

Toward Architectural Convergence

Evolution and role of software have blurred boundary

- Send/recv supported on SAS machines via buffers
- Can construct global address space on MP using hashing
- Page-based (or finer-grained) shared virtual memory

Hardware organization converging too

- Tighter NI integration even for MP (low-latency, high-bandwidth)
- At lower level, even hardware SAS passes hardware messages

Even clusters of workstations/SMPs are parallel systems

- Emergence of fast system area networks (SAN)

Programming models distinct, but organizations converging

- Nodes connected by general network and communication assists
- Implementations also converging, at least in high-end machines

Data Parallel Systems

Programming model:

- Operations performed in parallel on each element of data structure
- **Logically single thread of control**, performs sequential or parallel steps
- Conceptually, **a processor associated with each data element**

Architectural model:

- Array of many simple, cheap processors with little memory each
 - Processors don't sequence through instructions
- Attached to a **control processor that issues instructions**
- Specialized and general communication, **cheap global synchronization**

Original motivation:

- Matches simple differential equation solvers
- Centralize high cost of instruction fetch & sequencing

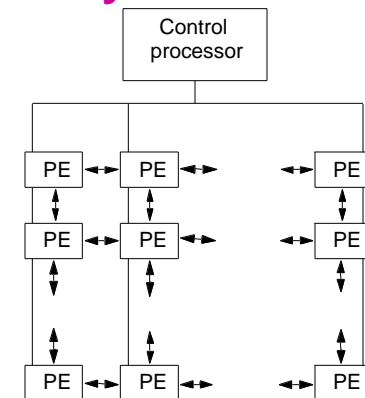

Application of Data Parallelism

- Each PE contains an employee record with his/her salary

```
If salary > 100K then
```

```
    salary = salary *1.05
```

```
else
```

```
    salary = salary *1.10
```

- Logically, the whole operation is a single step
- Some processors enabled for arithmetic operation, others disabled

Other examples:

- Finite differences, linear algebra, ...
- Document searching, graphics, image processing, ...

Some recent machines:

- Thinking Machines CM-1, CM-2 (and CM-5)
- Maspar MP-1 and MP-2,

Evolution and Convergence

Rigid control structure (**SIMD** in Flynn taxonomy)

- **SISD** = uniprocessor, **MIMD** = multiprocessor

Popular when cost savings of centralized sequencer high

- 60s when CPU was a cabinet; replaced by vectors in mid-70s
- Revived in mid-80s when 32-bit datapath slices just fit on chip
- No longer true with modern microprocessors

Other reasons for demise

- **Simple, regular applications have good locality, can do well anyway**
- **Loss of applicability** due to hardwiring data parallelism
 - MIMD machines as effective for data parallelism and more general

Programming model converges with **SPMD** (single program multiple data)

- Contributes need for **fast global synchronization**
- **Structured global address space**, implemented with either **SAS** or **MP**

Dataflow Architectures

Represent computation as a **graph of essential dependences**

- **Logical processor** at each node, activated by availability of operands
- Message (**tokens**) carrying **tag** of next instruction sent to next processor
- Tag compared with others in **matching store**; match fires execution

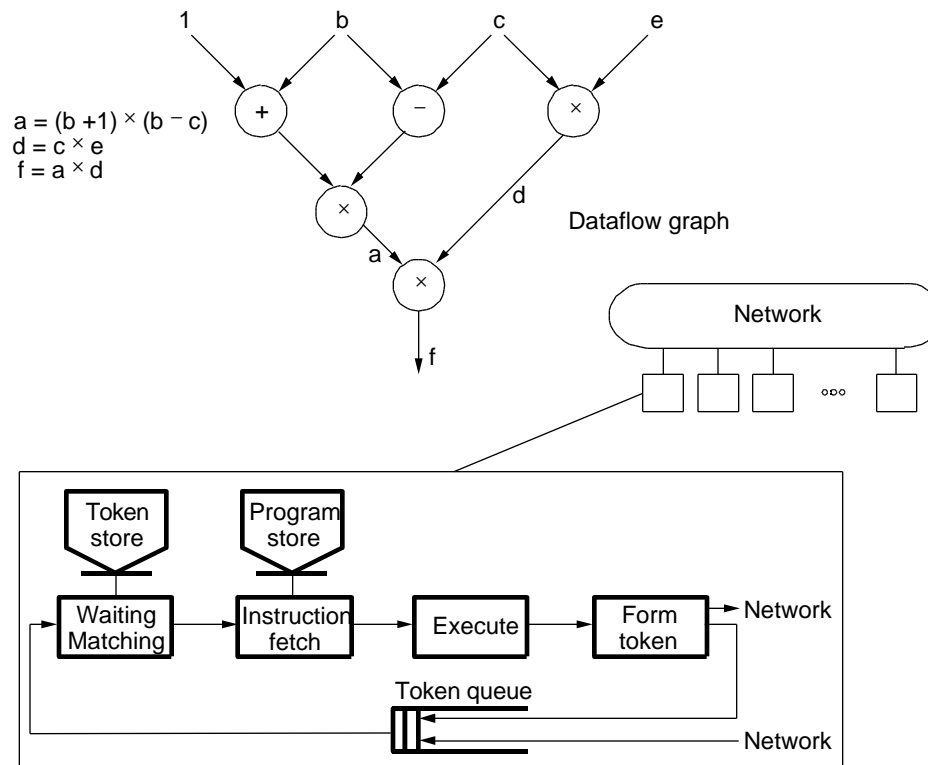

Evolution and Convergence

Key characteristics:

- Ability to name operations, synchronization, dynamic scheduling

Problems:

- Operations have locality across them, useful to group together
- Handling complex data structures like arrays
- Complexity of matching store and memory units
- Exposes too much parallelism (?)

Converged to use conventional processors and memory

- Support for large, dynamic set of threads to map to processors
- Typically shared address space as well
- But separation of programming model from hardware (like data parallel)

Lasting contributions:

- Integration of communication with thread (handler) generation
- Tightly integrated communication and fine-grained synchronization
- Remained useful concept for software (compilers etc.)

Systolic Architectures

- Replace single processor with **array of regular processing elements**
- **Orchestrate data flow** for high throughput with less memory access

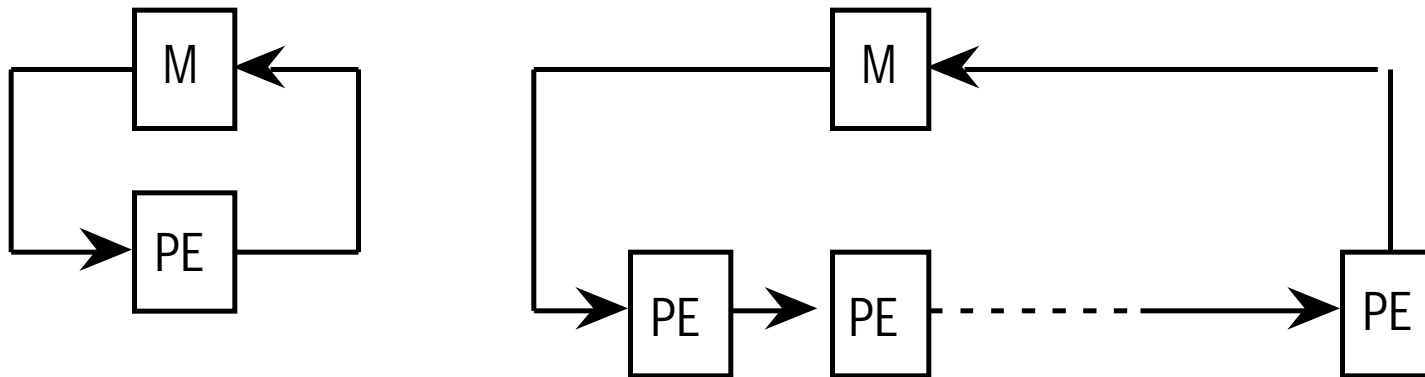

Different from pipelining:

- Nonlinear array structure, multidirection data flow, each PE may have (small) local instruction and data memory

Different from SIMD: each PE may do something different

Initial motivation: VLSI enables inexpensive special-purpose chips

Represent algorithms directly by chips connected in regular pattern

Systolic Arrays (Cont)

Example: Systolic array for 1-D convolution

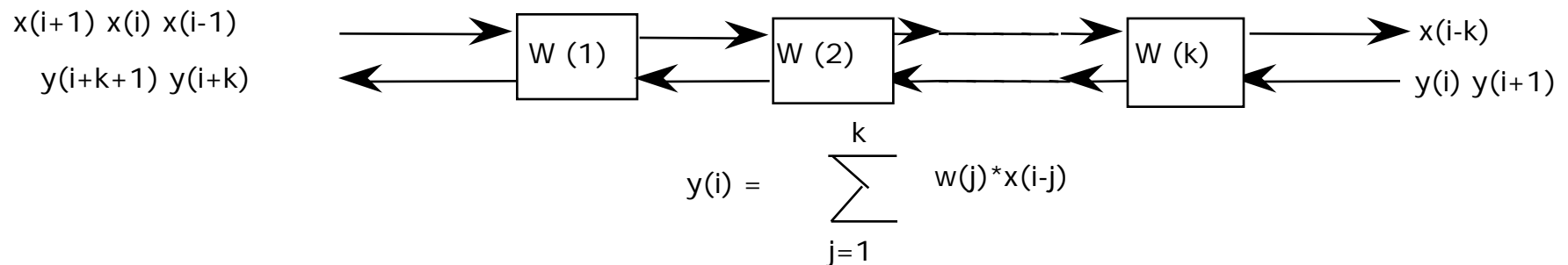

- **Practical realizations (e.g. iWARP) use quite general processors**
 - Enable variety of algorithms on same hardware
- **But dedicated interconnect channels**
 - Data transfer directly from register to register across channel
- **Specialized, and same problems as SIMD**
 - General purpose systems work well for same algorithms (locality etc.)

Convergence: General Parallel Architecture

A generic modern multiprocessor

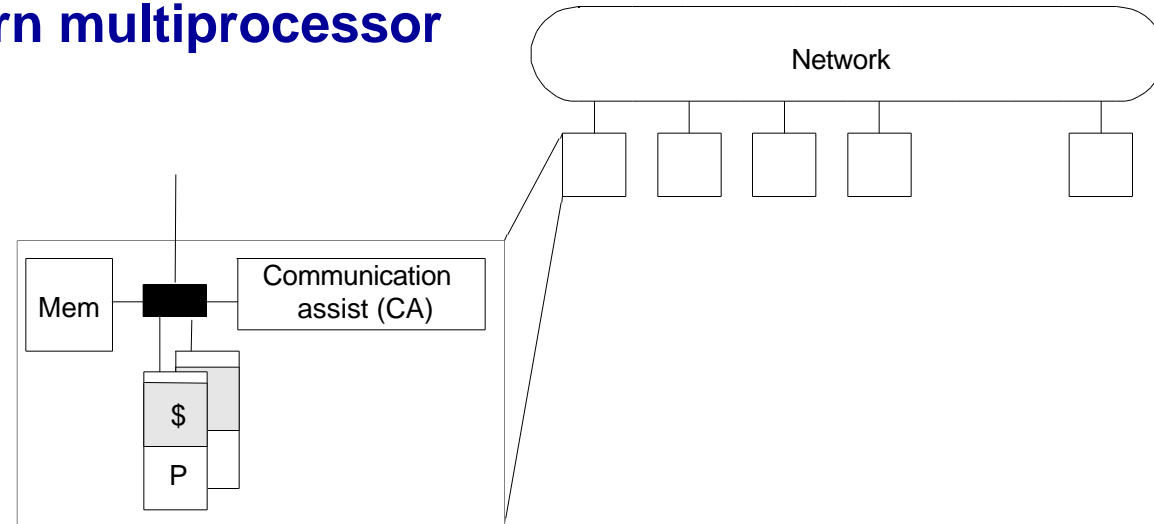

Node: processor(s), memory system, plus *communication assist*

- Network interface and communication controller
- Scalable network
- Convergence allows lots of innovation, now within framework
 - Integration of assist with node, what operations, how efficiently...

Fundamental Design Issues

Understanding Parallel Architecture

Traditional taxonomies not very useful

Programming models not enough, nor hardware structures

- Same one can be supported by radically different architectures

Architectural distinctions that affect software

- Compilers, libraries, programs

Design of user/system and hardware/software interface

- Constrained from **above by progr. models** and **below by technology**

Guiding principles provided by layers

- What primitives are provided at communication abstraction
- How programming models map to these
- How they are mapped to hardware

Fundamental Design Issues

At any layer, interface (contract) aspect and performance aspects

- **Naming**: How are logically shared data and/or processes referenced?
- **Operations**: What operations are provided on these data
- **Ordering**: How are accesses to data ordered and coordinated?
- **Replication**: How are data replicated to reduce communication?
- **Communication Cost**: Latency, bandwidth, overhead, occupancy

Understand at programming model first, since that sets requirements

Other issues:

- **Node Granularity**: How to split between processors and memory?
- ...

Sequential Programming Model

Contract

- **Naming:** **Can name any variable in virtual address space**
 - Hardware (and perhaps compilers) does translation to physical addresses
- **Operations:** **Loads and Stores**
- **Ordering:** **Sequential program order**

Performance

- Rely on dependences on single location (mostly): *dependence order*
- Compilers and hardware **violate other orders without getting caught**
- **Compiler:** reordering and register allocation
- **Hardware:** out of order, pipeline bypassing, write buffers
- **Transparent replication in caches**

SAS Programming Model

Naming:

- Any process can name any variable in shared space

Operations:

- Loads and stores, plus those needed for ordering

Simplest Ordering Model:

- Within a process/thread: sequential program order
- Across threads: some interleaving (as in time-sharing)
- Additional orders through synchronization
- Again, compilers/hardware can violate orders without getting caught
 - Different, more subtle ordering models also possible (discussed later)

Synchronization

Mutual exclusion (locks)

- Ensure certain operations on certain data can be performed by only one process at a time
- Room that only one person can enter at a time
- No ordering guarantees

Event synchronization

- Ordering of events to preserve dependences
 - e.g. producer → consumer of data
- 3 main types:
 - point-to-point
 - global
 - group

Message Passing Programming Model

Naming: Processes can name private data directly.

- No shared address space

Operations: Explicit communication via *send* and *receive*

- Send transfers data from private address space to another process
- Receive copies data from process to private address space
- Must be able to name processes

Ordering:

- Program order within a process
- Send and receive can provide *pt-to-pt synch* between processes
- Mutual exclusion inherent

Can construct global address space:

- Process number + address within process address space
- But *no direct operations on these names*

Design Issues Apply at All Layers

Programming model's position provides constraints/goals for system

In fact, each interface between layers supports or takes a position on:

- **Naming model**
- **Set of operations on names**
- **Ordering model**
- **Replication**
- **Communication performance**

Any set of positions can be mapped to any other by software

Let's see issues across layers:

- **How lower layers can support contracts of programming models**
- **Performance issues**

Naming and Operations

Naming and operations in programming model can be directly supported by lower levels, or translated by compiler, libraries or OS

Example: **Shared virtual address space in programming model**

Hardware interface supports *shared physical address space*

- Direct support by hardware through v-to-p mappings, no software layers

Hardware supports independent physical address spaces

- **Can provide SAS through OS, so in system/user interface**
 - v-to-p mappings only for data that are local
 - remote data accesses incur page faults; brought in via page fault handlers
 - same programming model, different hardware requirements and cost model
- **Or through compilers or runtime, so above sys/user interface**
 - shared objects, instrumentation of shared accesses, compiler support

Naming and Operations (Cont)

Example: **Implementing Message Passing**

Direct support at hardware interface

- But match and buffering benefit from more flexibility

Support at system/user interface or above in software (almost always)

- Hardware interface provides basic data transport (well suited)
- Send/receive built in software for flexibility (protection, buffering)
- Choices at user/system interface:
 - OS each time: expensive
 - OS sets up once/infrequently, then little software involvement each time
- Or lower interfaces provide SAS, and send/receive built on top with buffers and loads/stores

Need to examine the issues and tradeoffs at every layer

- Frequencies and types of operations, costs

Ordering

Message passing: no assumptions on orders across processes except those **imposed by send/receive pairs**

SAS: How processes see the order of other processes' references defines semantics of SAS

- **Ordering very important and subtle**
- Uniprocessors play tricks with orders to gain parallelism or locality
- These are more important in multiprocessors
- Need to understand which old tricks are valid, and learn new ones
- How programs behave, what they rely on, and hardware implications

Replication

Very important for reducing data transfer/communication

Again, depends on naming model

Uniprocessor: caches do it automatically

- Reduce communication with memory

Message Passing naming model at an interface

- A receive replicates, giving a new name; subsequently use new name
- **Replication is explicit in software** above that interface

SAS naming model at an interface

- A load brings in data transparently, so **can replicate transparently**
- Hardware caches do this, e.g. in shared physical address space
- OS can do it at page level in shared virtual address space, or objects
- No explicit renaming, many copies for same name: **coherence problem**
 - in uniprocessors, “coherence” of copies is natural in memory hierarchy

Communication Performance

Performance characteristics determine usage of operations at a layer

- Programmer, compilers etc make choices based on this

Fundamentally, **three characteristics**:

- **Latency**: time taken for an operation
- **Bandwidth**: rate of performing operations
- **Cost**: impact on execution time of program

If processor does one thing at a time: **bandwidth** $1/\text{latency}$

- But actually **more complex in modern systems**

Characteristics apply to overall operations, as well as individual components of a system, however small

We will focus on communication or data transfer across nodes

Communication Cost Model

Communication Time per Message

= *Overhead* + *Assist Occupancy* + *Network Delay* + *Size/Bandwidth* + *Contention*

= $o_v + o_c + l + n/B + T_c$

Overhead and assist occupancy may be $f(n)$ or not

Each component along the way has occupancy and delay

- Overall delay is sum of delays
- Overall occupancy (1/bandwidth) is biggest of occupancies

Comm Cost = frequency * (Comm time - overlap)

General model for data transfer: applies to cache misses too

Summary of Design Issues

Functional and performance issues apply at all layers

Functional: Naming, operations and ordering

Performance: Organization, latency, bandwidth, overhead, occupancy

Replication and communication are deeply related

- Management depends on naming model

Goal of architects: design against frequency and type of operations that occur at communication abstraction, constrained by tradeoffs from above or below

- Hardware/software tradeoffs

Recap

Parallel architecture is an important thread in the evolution of architecture

- At all levels
- Multiple processor level now in **mainstream** of computing

Exotic designs have contributed much, but given way to convergence

- Push of technology, cost and application performance
- Basic processor-memory architecture is the same
- Key architectural issue is in **communication architecture**

Fundamental design issues:

- Functional: **naming, operations, ordering**
- Performance: **organization, replication, performance characteristics**

Design decisions driven by workload-driven evaluation

- Integral part of the engineering focus